

MAZDA ROTARY ENGINE AUXILIARY CONTROLS

RX-7

DESCRIPTION

In addition to the regular exhaust emission control systems previously described, RX-7 models use several other "auxiliary" emission control devices. Some of these units may work in conjunction with systems previously explained, or they may have an independent function. These auxiliary controls include the control unit, idle switch (Man. Trans.), choke switch, full choke switch, acceleration sensor with delay valve (all Auto. Trans. and Calif. Man. Trans.), top switch and overdrive switch (Man. Trans.) or kickdown switch (Auto. Trans.), No. 1 water temperature switch and No. 2 water temperature switch (Federal only).

TESTING

CONTROL UNIT

1) Check condition of 5-amp fuse, which is located under terminal connectors.

2) Referring to illustration for terminal locations, check that current flows to terminals "A" and "B" when engine is operating at idle (about 3-8 volts).

3) Connect negative probe of voltmeter to terminal "P" and positive probe to other terminals as described below and check that 12 volts exist under conditions described:

- At terminal "J" with decreasing engine speed less than 1150 RPM.
- At terminal "J" with engine operating and applying battery power (with jumper wire) to terminal "E" or "T".
- At terminal "L" with decreasing engine speed less than 1150 RPM.
- At terminal "M" or "Q" when applying battery power to terminal "S", engine speed should increase less than 4600 RPM of idle within 130 seconds after engine start with choke knob fully out.
- At terminal "M" when applying battery power to terminal "E" and engine operating.
- At terminal "D" at any engine operating condition.
- At terminal "R" while applying battery power to terminal "S" with engine speed increasing less than 3000 RPM of idle.
- At terminal "R" while applying battery power to terminal "S" at engine speed less than 4600 RPM within 130 seconds after starting engine with choke knob fully out.
- At terminal "G" or "I" with decreasing engine speed more than 1150 RPM.
- At terminal "U" at any engine operating condition (Calif.). When ignition switch is "ON" and/or within 60 seconds after starting engine with choke knob fully out with engine operating or stalled (Federal).
- At terminal "V" (Calif. only) while applying battery power to terminal "S" at engine speed less than 4600 RPM within 130 seconds after starting engine with choke knob fully out.
- At terminal "V" (Calif. only) while applying battery power to terminal "F" or "O" at any engine operating condition.

- At terminal "F" or "H" with decreasing engine speed less than 1150 RPM.
- At terminal "K" at any engine operating condition.

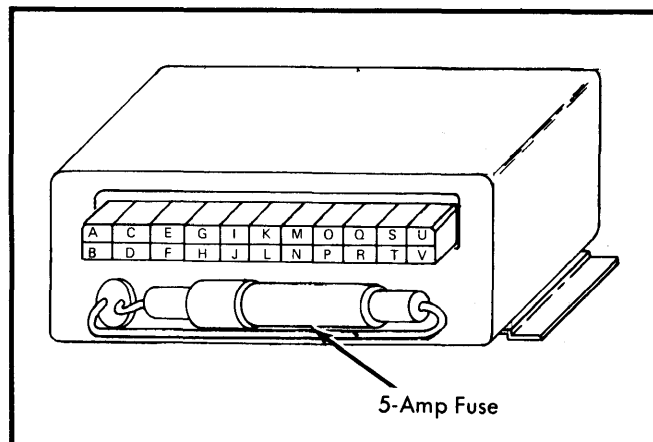

Fig. 1 Showing Terminal Locations on Control Unit

CHOKE SWITCH

1) Disconnect coupler from choke switch. Check continuity between numbered terminals in coupler, using an ohmmeter.

2) Continuity should exist between No. 3 and No. 7 terminals when choke knob is pulled out about 0.4" (10 mm). See Fig. 2 for terminal locations.

FULL CHOKE SWITCH

1) Disconnect coupler from choke switch. Check continuity between numbered terminals in coupler, using an ohmmeter.

2) Continuity should exist between No. 4 and No. 5 terminals when choke knob is pulled out about 1" (25 mm).

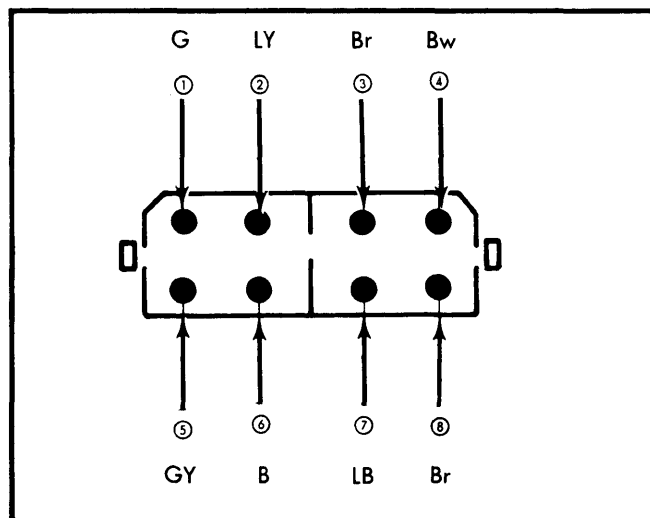

Fig. 2 Coupler Terminal Locations for Testing Choke and Full Choke Switches

1980 Exhaust Emission Systems

MAZDA ROTARY ENGINE AUXILIARY CONTROLS (Cont.)

IDLE SWITCH (MAN. TRANS.)

1) Disconnect coupler from idle switch. Check continuity between numbered terminals in coupler using an ohmmeter.

2) With engine at idle, there should be continuity between No. 1 and No. 3 terminals and no continuity between No. 1 and No. 2.

3) Increase engine speed to 1000 RPM with throttle. There should be continuity between No. 1 and No. 2 and no continuity between No. 1 and No. 3.

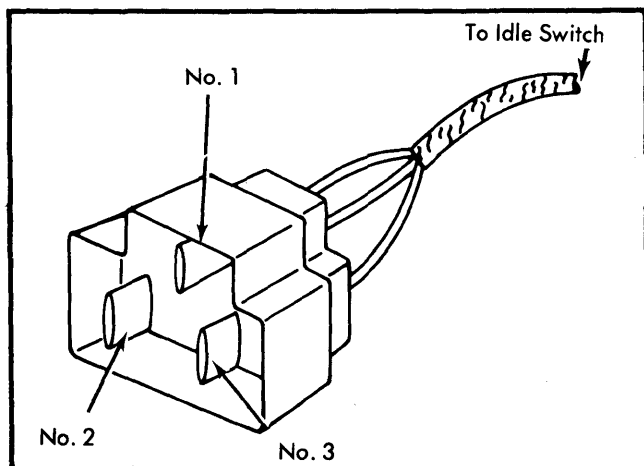

Fig. 3 Showing Idle Switch Terminal Locations

ACCELERATION SENSOR & DELAY VALVE (AUTO. TRANS. & CALIF. MAN. TRANS.)

Acceleration Sensor – 1) Disconnect vacuum switch coupler and connect an ohmmeter to terminals "A" and "B". Start engine and run at idle.

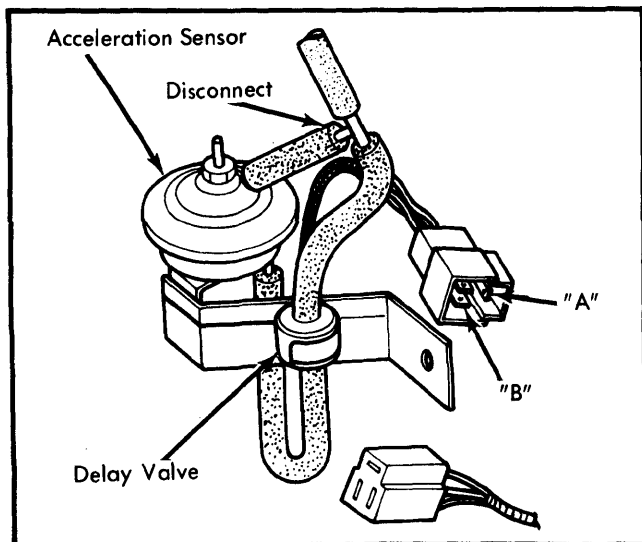

Fig. 4 Testing Acceleration Sensor
(Auto. Trans. & Calif. Man. Trans.)

2) There should be no continuity between terminals.

3) Now, disconnect vacuum sensing tube from vacuum switch and make sure that continuity exists between both terminals.

Delay Valve – 1) Disconnect vacuum switch coupler and connect an ohmmeter to coupler terminals "A" and "B". Start engine and run at idle.

2) Increase engine speed to 3000 RPM with throttle and keep throttle lever in this position for 2-3 seconds.

3) Quickly release throttle and check continuity between terminals. It should exist for 3-25 seconds.

CHOKE RELAY

1) Disconnect coupler from relay. With engine off and no power applied, check continuity of terminals.

2) There should be continuity between No. 1 and No. 2. There should be no continuity between No. 3 and No. 4.

3) Now, connect a wire from the battery positive post to terminal No. 6 and battery negative post to terminal No. 5.

4) There should be continuity between No. 3 and No. 4. There should be no continuity between No. 1 and No. 2.

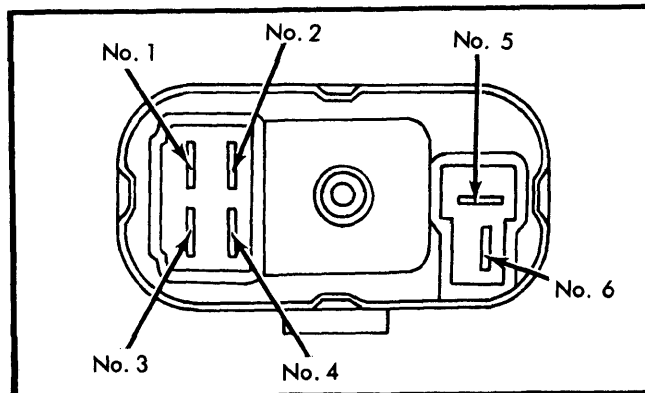

Fig. 5 Showing Terminal Locations for Testing
Choke Relay

TOP SWITCH & OVERDRIVE SWITCH (MAN. TRANS.)

Top Switch – 1) Raise vehicle and support with stands. Detach top switch bullet connectors (top switch is located on left side of transmission, just behind clutch lever boot).

2) Connect ohmmeter to both connectors on top switch side and check that no continuity exists when shifting into 4th gear.

Overdrive Switch – 1) Raise and support vehicle. Detach overdrive switch bullet connectors (switch is located on left side of transmission extension housing).

2) Connect ohmmeter to both switch terminals. Check that no continuity exists when shifting into 5th (overdrive) gear.

MAZDA ROTARY ENGINE AUXILIARY CONTROLS (Cont.)

KICK-DOWN SWITCH (AUTO. TRANS.)

1) Raise and support vehicle. Detach kick-down switch coupler from wiring harness (coupler is located on left side of transmission, just behind starter).

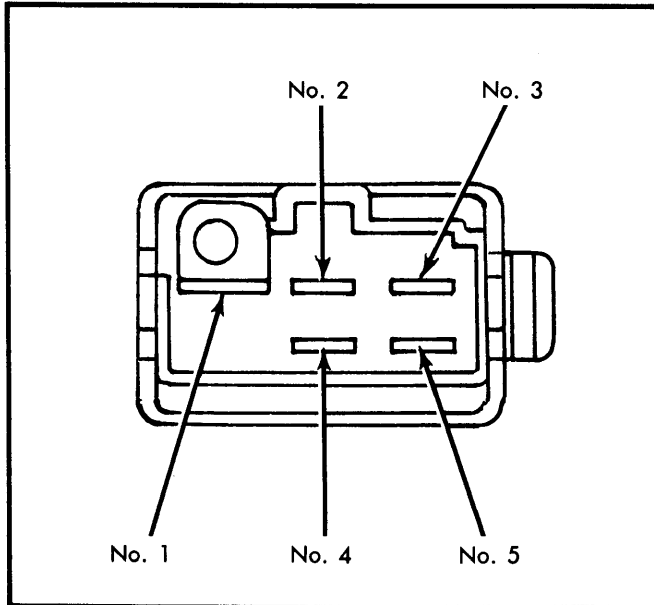

Fig. 6 Showing Terminal Locations for Testing Kick-Down Relay

2) Connect a voltmeter to terminal and good ground. Start engine and run at idle. Slowly increase engine speed to 2000 RPM, using choke knob. Current should flow to coupler.

3) Reconnect coupler and detach electrical connector from kick-down relay (located on fender well, close to brake booster).

4) Connect ohmmeter. With engine off and no power applied, there should be continuity between No. 1 and No. 5. There should be no continuity between No. 1 and No. 3.

5) Connect a wire from battery positive post to terminal No. 2 and battery negative post to terminal No. 4. There should be continuity between No. 1 and No. 3. There should be no continuity between No. 1 and No. 5.

WATER TEMPERATURE SWITCHES

No. 1 Switch — Remove switch from water pump housing. Place switch in water with a thermometer. Connect ohmmeter to switch coupler and gradually heat water. Continuity between terminals should not exist when temperature reaches 158°F (70°C). If switch does not respond as described, replace No. 1 water temperature switch.

No. 2 Switch (Federal Models Only) — Remove switch from top radiator tank and perform same test as for No. 1 water temperature switch. Continuity should not exist between terminals of No. 2 switch when temperature is below 5°F (-15°C). If switch does not respond as described, replace No. 2 water temperature switch.