

MAZDA ROTARY ENGINE IDLE COMPENSATION SYSTEM

RX-7

DESCRIPTION

The Idle Compensation system is installed to control the air/fuel mixture under varying engine operating conditions. The system consists of idle compensator, altitude compensator and throttle opener (air conditioned models).

OPERATION

IDLE COMPENSATOR

The idle compensator is a bimetal valve installed in the air cleaner. The bimetal valve opens at 149°F (65°C) to supply additional air to intake manifold to lean the air/fuel mixture for more complete burning.

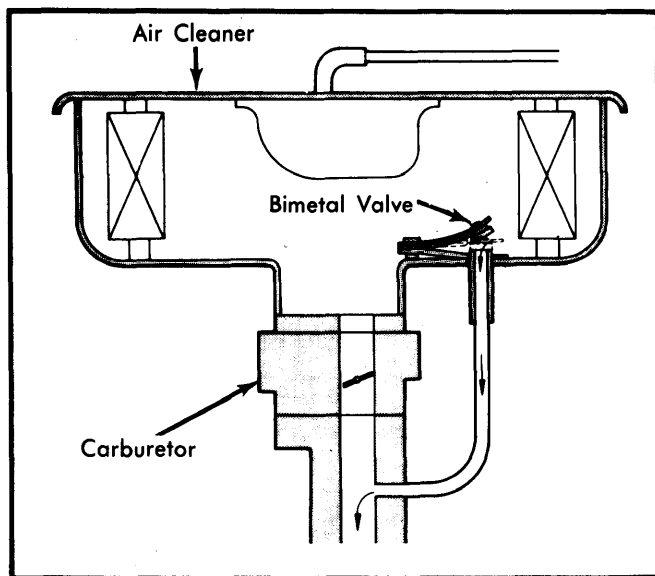

Fig. 1 Schematic of Idle Compensator

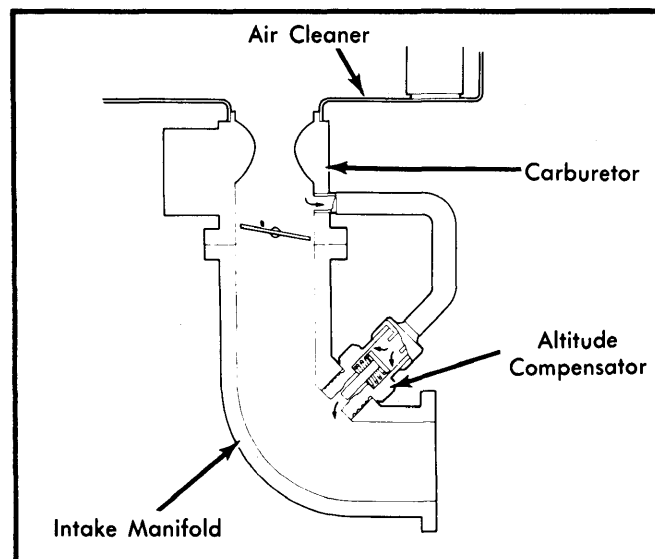

Fig. 2 Schematic of Altitude Compensator

ALTITUDE COMPENSATOR

The altitude compensator is installed below the carburetor on the intake manifold. The altitude compensator supplies additional air to intake manifold during idle mode in high altitude areas to stabilize engine operation.

THROTTLE OPENER (AIR CONDITIONED MODELS)

The throttle opener consists of air conditioner relay, air conditioner solenoid valve, servo diaphragm and connecting hoses and wires. The throttle opener opens the primary throttle valve when air conditioner is operated at engine speeds below 1150 RPM to maintain smooth idle operation.

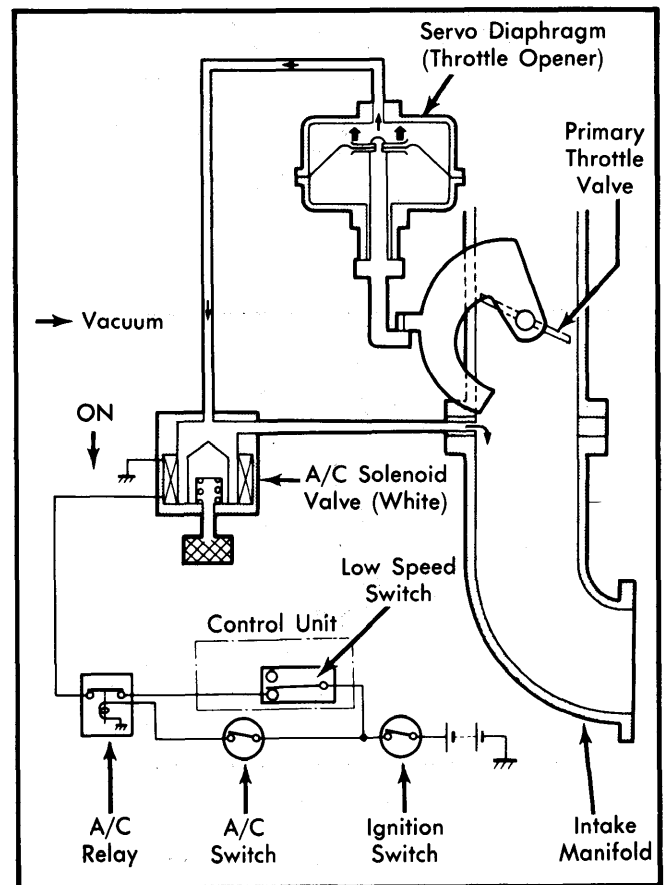

Fig. 3 Schematic of Throttle Opener

TESTING

IDLE COMPENSATOR

Remove air cleaner cover and filter element. When bimetal temperature is below 149°F (65°C), valve should be closed and no air leakage should exist when vacuum is applied to tube. Bimetal valve should be open when temperature exceeds 159°F (69°C). If valve does not function as described, replace valve.

1980 Exhaust Emission Systems

MAZDA ROTARY ENGINE IDLE COMPENSATION SYSTEM (Cont.)

ALTITUDE COMPENSATOR

- 1) Remove air cleaner and disconnect altitude compensator hose from carburetor. Connect tachometer. Start engine and run at specified idle RPM with transmission in neutral or "Park".
- 2) With engine idling, cover end of tube with finger and note RPM drop. If idle speed drop is not within specifications shown in table, replace altitude compensator.

High Altitude Compensator Specifications (Idle RPM Drop)

Altitude	RPM Drop
Under 3280 Ft.	10-100
3280-6560 Ft.	50-200
Over 6560 Ft.	More than 100

AIR CONDITIONER SOLENOID VALVE

Electrical Signal Check - 1) Warm engine to normal operating temperature. Stop engine and connect tachometer. Disconnect air conditioner solenoid valve (white color dot) coupler and connect voltmeter to wiring harness terminals. Connect positive probe to "GW" wire, negative probe to "B" wire.

- 2) Start engine and turn air conditioner "ON". Increase engine speed to 2000 RPM, using throttle. Slowly decrease engine speed. Current should flow to terminals when engine speed is 1050-1250 RPM.

Vacuum Signal Check - 1) Disconnect vacuum sensing hoses from solenoid valve and vacuum port (rear of valve). Blow through vacuum hose and ensure air passes through valve and escapes through filter.

- 2) Disconnect solenoid valve coupler and apply battery power to terminals with jumper wire. Blow through hose again. Air should pass through valve and escape at rear vacuum port.

AIR CONDITIONING RELAY

- 1) Disconnect coupler from air conditioner relay. Check continuity between terminals, using an ohmmeter.
- 2) With engine off and no power applied, there should be continuity between No. 1 and No. 5. There should be no continuity between No. 1 and No. 3.
- 3) Connect a wire from battery positive post to terminal No. 2 and battery negative post to terminal No. 4. There should be continuity between No. 1 and No. 3. There should be no continuity between No. 1 and No. 5.

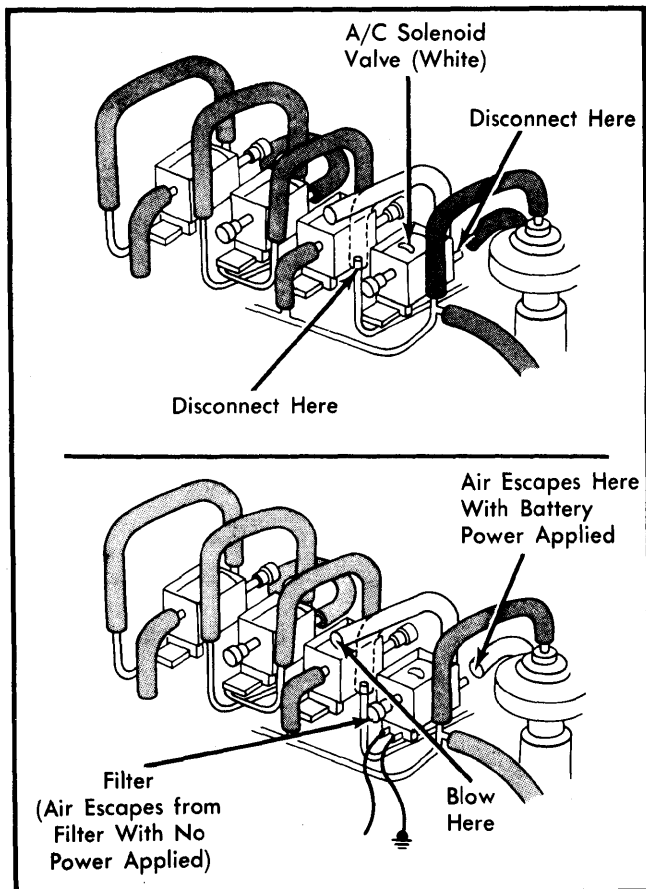

Fig. 4 Schematic Showing Hose Disconnection for Testing Air Conditioning Solenoid Valve

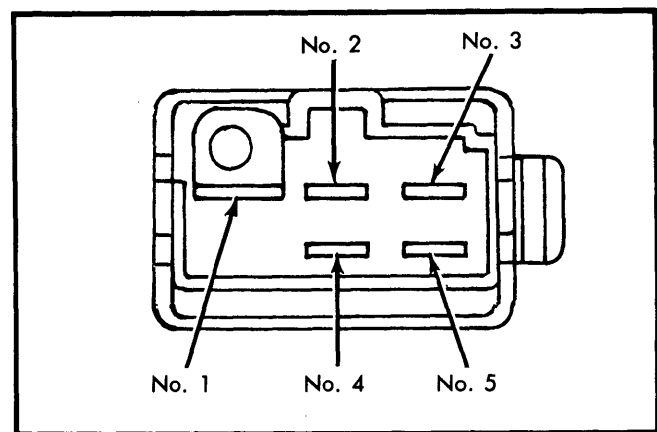

Fig. 5 Showing Terminal Locations for Testing Air Conditioning Relay

THROTTLE OPENER

- 1) Switch off all accessories. Disconnect and plug idle compensator tube at air cleaner. Connect tachometer to engine and warm engine to normal operating temperature.
- 2) Turn air conditioner "OFF". Disconnect air conditioner solenoid valve coupler. Connect a wire from battery positive post to solenoid terminal, connect other terminal to ground.
- 3) Throttle opener should operate and engine speed should increase to 1150-1250 RPM. If engine speed is not within specification, turn adjusting nut on throttle opener arm until engine speed is within specification.