

FIAT AIR GULP SYSTEM

Brava (Federal Only)
 Spider 2000 (Federal w/Carb. Only)
 Strada (Federal Only)
 X1/9 (Federal Only)

DESCRIPTION

The Air Gulp system is designed to prevent backfiring in the exhaust system during sudden deceleration. During deceleration, the air/fuel mixture becomes overly rich. This causes uncontrolled combustion in the exhaust system (engine backfiring). To prevent this, the air gulp system supplies fresh air to the engine during deceleration. This leans out the air/fuel mixture and allows normal combustion to occur, eliminating the backfiring.

The system consists of a gulp valve which supplies fresh air to the intake manifold. The valve is controlled by a vacuum signal taken from a tap on the intake manifold. The vacuum signal is controlled by an electro-valve. The electro-valve is energized during engine starting by the starting circuit and during cold engine operation by a thermo switch.

OPERATION

During engine starting, the electro-valve is energized. With the valve energized, the vacuum signal is applied directly to the upper chamber of the gulp valve. This prevents gulp valve from opening.

During cold engine operation, the thermo switch is closed, energizing the electro-valve. With the electro-valve energized, the vacuum signal is applied directly to the upper chamber of the gulp valve. This prevents the gulp valve from opening, thereby preventing any interference with the air/fuel mixture provided by the automatic choke.

During warm engine operation, the thermo switch is opened. The electro-valve is de-energized, allowing the vacuum signal to reach the gulp valve. The gulp valve opens, supplying fresh air to the intake manifold. The vacuum signal is strongest during deceleration.

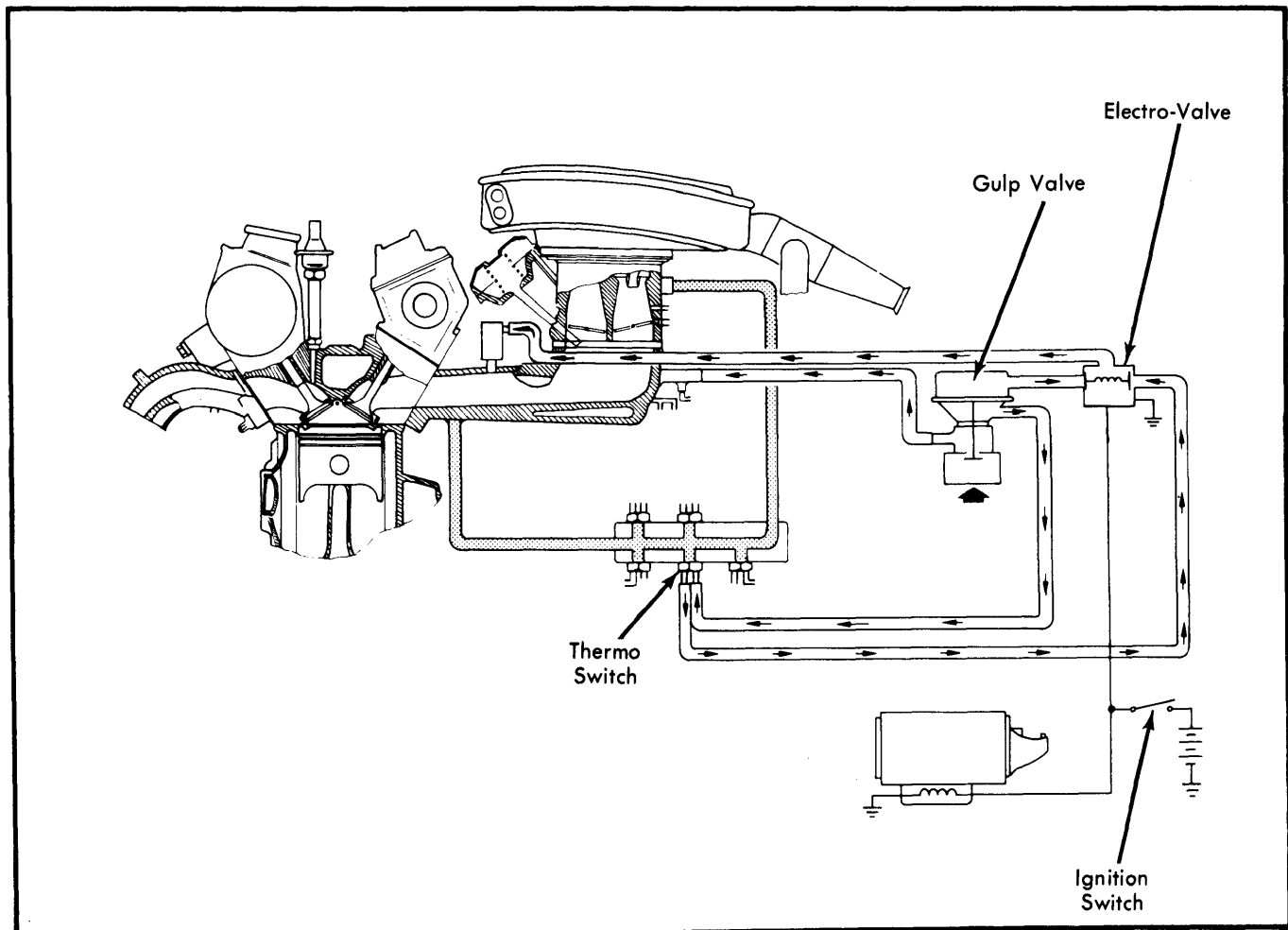

Fig. 1 Fiat Air Gulp System
 (Brava and Spider Models Shown - Strada and X1/9 Models Similar)