

1980 Exhaust Emission Systems

FIAT AIR INJECTION SYSTEM

Brava (Federal Only)
Spider 2000 (Federal w/Carb. Only)
Strada (Federal Only)
X1/9 (Federal Only)

DESCRIPTION

The Air Injection system reduces carbon monoxide (CO) and hydrocarbon (HC) emissions by injecting fresh air from a belt-driven air pump into the exhaust gas stream as it leaves the combustion chambers. The oxygen in the fresh air, plus the heat of the exhaust gases, causes further oxidation (burning) of the exhaust gases, thereby reducing CO and HC emissions. The system consists of a belt-driven air pump, an external air delivery line, a pump pressure relief valve, a check valve, and passages in the cylinder head to complete the air delivery system.

OPERATION

The air pump is a low pressure unit, belt driven by the engine, which uses vanes on its drive pulley as a centrifugal filter. The air delivery line is connected to the check valve. The check valve prevents hot exhaust gases from flowing out through the delivery line and pump in case the pump fails or exhaust gas pressure becomes excessive. A relief valve, mounted on the air pump on Strada and X1/9 models or on the air cleaner on Brava and Spider models, is used to vent excess pump pressure. Pump output which passes through the check valve enters the cylinder head passages and is delivered to the exhaust ports.

MAINTENANCE

Every 15,000 miles the following should be performed:

- Inspect the air injection pump for defects or damage.
- Inspect relief valve and check valve operation and connections.
- Check condition of lines and fittings and replace parts as necessary.

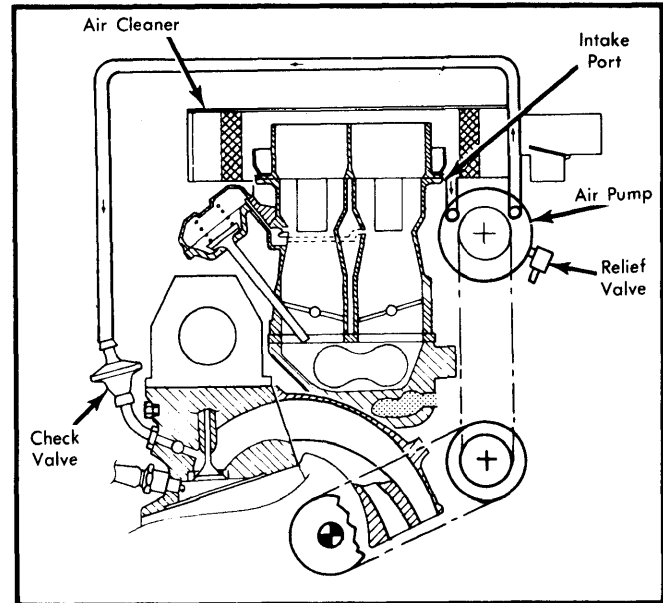

**Fig. 1 Fiat Air Injection System
(Strada and X1/9 Models)**

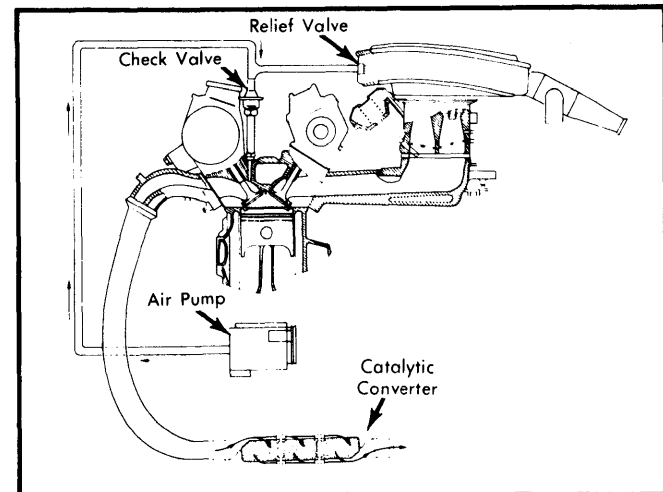

**Fig. 2 Fiat Air Injection System
(Brava and Spider 2000 Models)**