

# 1980 Exhaust Emission Systems

## DATSUN TRANSMISSION CONTROLLED SPARK SYSTEM

Pickup (Calif. Man. Trans. Only)

### DESCRIPTION

The Transmission Controlled Spark system is used to reduce HC and NOx emissions by controlling distributor vacuum advance. Through the use of various switches and valves, this system allows vacuum advance only when transmission is in 4th or 5th gear. System consists of the following components:

- Vacuum Switching Valve
- Top Gear Detecting Switch

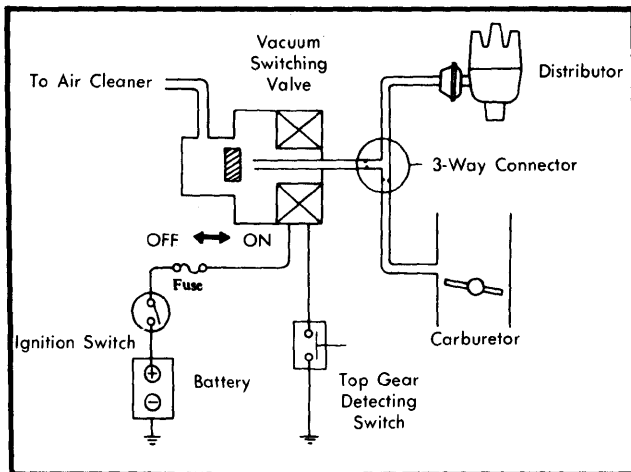

Fig. 1 Datsun Transmission Controlled Spark System

### OPERATION

When transmission is shifted into 4th or 5th gear, the top gear detecting switch on the transmission sends an electrical signal to the vacuum switching valve. This signal activates the vacuum switching valve, closing the vent passage and allowing full vacuum to the distributor vacuum advance unit. In all other gear positions, the vacuum switching valve interrupts the vacuum normally directed to the vacuum advance unit and, at the same time, opens the vent passage so that vacuum can be released.

### TESTING

#### TRANSMISSION CONTROLLED SPARK SYSTEM

Before testing the Transmission Controlled Spark system, make sure all electrical and vacuum lines are properly connected and that distributor vacuum advance unit is functioning correctly. Connect a timing light to engine and proceed as follows:

- 1) Apply parking brake and block drive wheels. Start engine and adjust engine speed to 2000 RPM. Check ignition timing.
- 2) Depress clutch pedal to disengage clutch, then recheck timing with transmission in 4th or 5th gear. System is functioning properly if ignition timing or engine speed in 4th or 5th gear is greater than that in neutral.
- 3) If timing or engine speed does not increase, test individual system components to locate cause.

#### VACUUM SWITCHING VALVE

- 1) With engine at normal operating temperature, disconnect vacuum switching valve wires at connectors and connect a timing light to engine.
- 2) Start engine and adjust engine speed to 2000 RPM. Check ignition timing.
- 3) Connect one of the switching valve wires directly to the battery positive terminal and connect the other wire to ground. Recheck ignition timing.
- 4) Vacuum switching valve is good if ignition timing varies with wire connected to battery voltage. If not, replace vacuum switching valve.

#### TOP GEAR DETECTING SWITCH

- 1) To test for proper "ON/OFF" operation of top gear detecting switch, connect ohmmeter leads to detecting switch leads and shift transmission from 4th or 5th gear to other forward gears and check for continuity.

**CAUTION** — Ignition switch must be in the "OFF" position for this test, or ohmmeter damage will result.

- 2) The top gear detecting switch is good if ohmmeter shows continuity with transmission in 4th or 5th gear and no continuity with transmission in any other gear. If not, replace top gear detecting switch.

#### ELECTRICAL WIRING CIRCUIT

- 1) Turn ignition switch "ON" but do not start engine. Check for voltage across test connector terminals "A" and "B".
- 2) Electrical wiring circuit is okay if voltmeter reads 0 volts with transmission in 4th or 5th gear and 12 volts in all other gears. If not, check for loose harness connections and blown fuse.

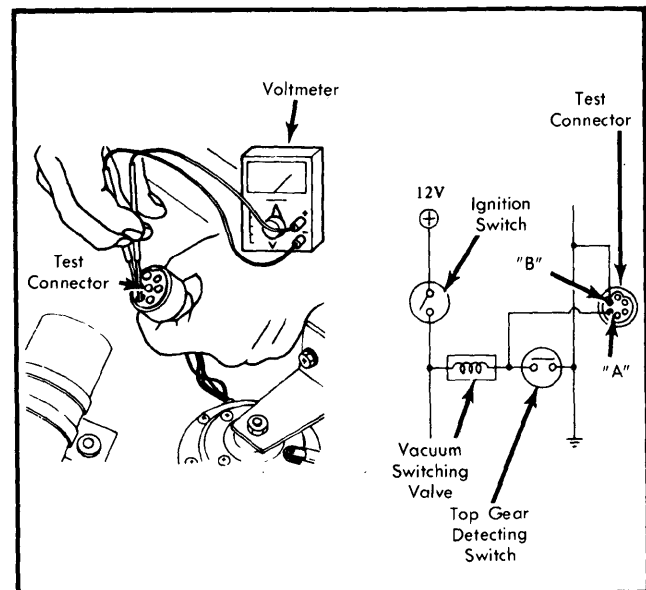

Fig. 2 Checking Electrical Wiring Circuit Schematic