

BOSCH LAMBDA CIS INJECTION SYSTEM – ALL MODELS

Audi
 4000 (Calif. Only)
 5000 (Calif. Only)
 5000 Turbo
BMW 320i
Mercedes-Benz
 280 Series
 450 Series
Peugeot 505
Porsche
 911SC
 924
 924 Turbo

Saab
 99
 900
 900 Turbo
Volkswagen (Calif. Only)
 Dasher
 Jetta
 Rabbit
 Scirocco
 Rabbit Pickup
Volvo
 All Models

The system consists of the mixture control unit (air flow sensor and fuel distributor), control pressure regulator, auxiliary air valve, cold start valve, thermo-time switch, injector nozzles, fuel pump, filter, oxygen sensor, electronic control unit, frequency valve, and catalytic converter. Some models use additional components, such as a thermo-vacuum valve or hot start pulse relay.

OPERATION

MIXTURE CONTROL UNIT

The air flow sensor contains a plate mounted on a hinged lever which moves in a cone shaped venturi. All engine air is drawn through this sensor. The plate moves as air passes through, pulling the hinged lever up or down. This raises or lowers a fuel control plunger in the fuel distributor, determining the amount of fuel to be injected into each cylinder. The movement of the plate is controlled by air flow, cone shape of venturi, a balance weight, and fuel pressure.

DESCRIPTION

The Bosch Continuous Injection System is a mechanical fuel injection system operated by incoming air flow. The Lambda system is a feedback control capable of measuring air/fuel ratios and correcting them constantly. The combination of the 2 systems makes it possible to obtain good economy and performance while minimizing exhaust emissions.

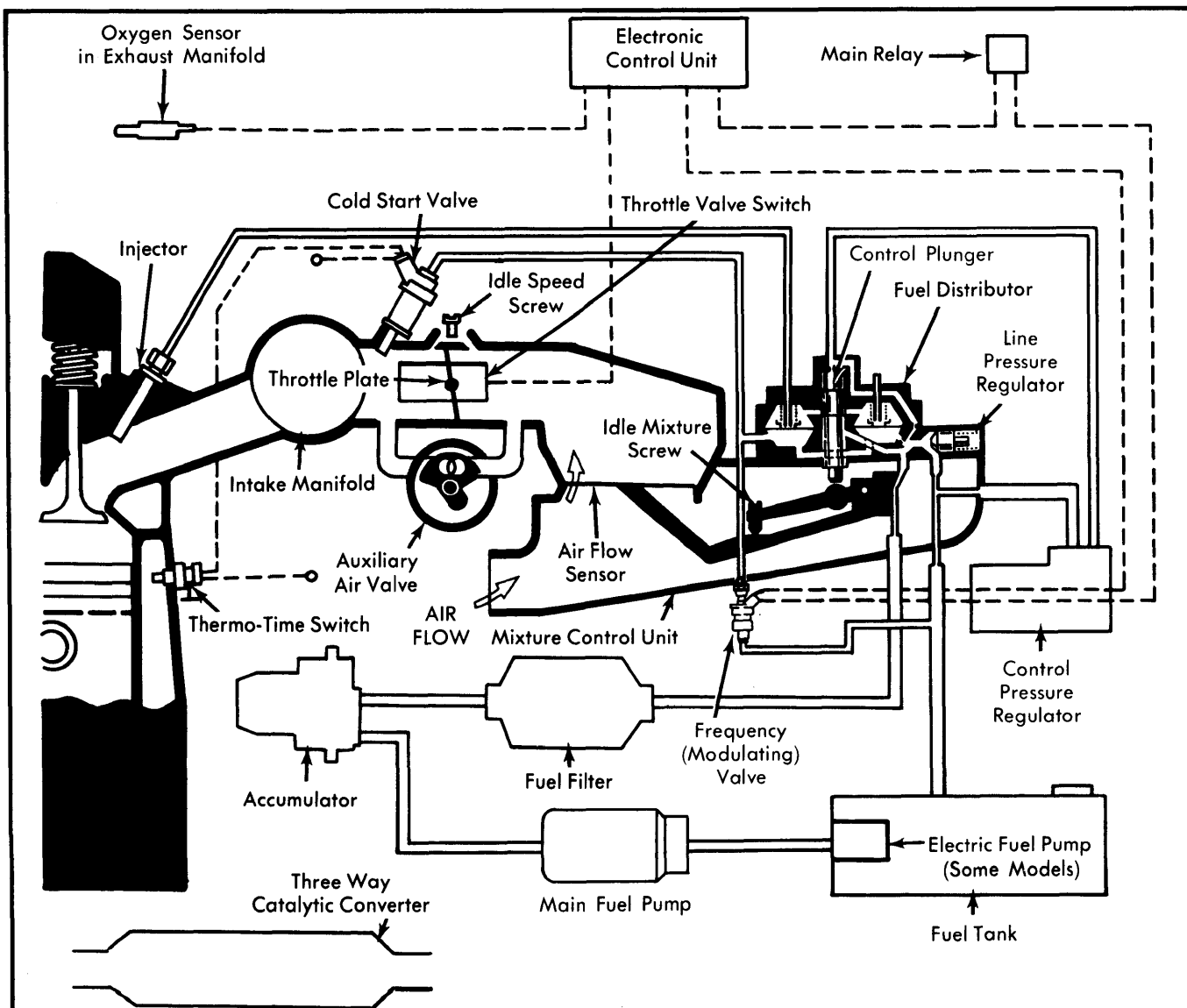

Fig. 1 Bosch CIS Lambda Fuel Injection System Diagram (Typical of All Models – Details May Vary)

BOSCH LAMBDA CIS INJECTION SYSTEM – ALL MODELS (Cont.)

NOTE – Air flows UP through the sensor on most inline engines, and DOWN through the sensor on V6, V8, and turbocharged engines. The direction of air flow does not affect system operation, it is changed for convenience of routing air flow.

Fuel distribution can be equal only if the pressure to each injector is equal. Pressure regulating valves in the fuel distributor equalize system pressure. These valves are adjusted during assembly of distributor and cannot be adjusted in service.

CONTROL PRESSURE REGULATOR

The control pressure regulator provides fuel pressure to the top of the plunger in the fuel distributor. Reduced pressure allows the plate to move farther with the same air flow. This supplies more fuel to the cylinders to improve warming up. As the engine reaches operating temperature (or a pre-determined time elapses) the control pressure regulator increases control pressure, leaning the air/fuel mixture.

A bi-metal strip in the control pressure regulator is heated by an electric coil. As it heats up, it gradually increases the control pressure. If the electrical connections are not good, the warm-up function of the regulator will not operate. Some regulators have an altitude-sensitive function that compensates for changes in barometric pressure.

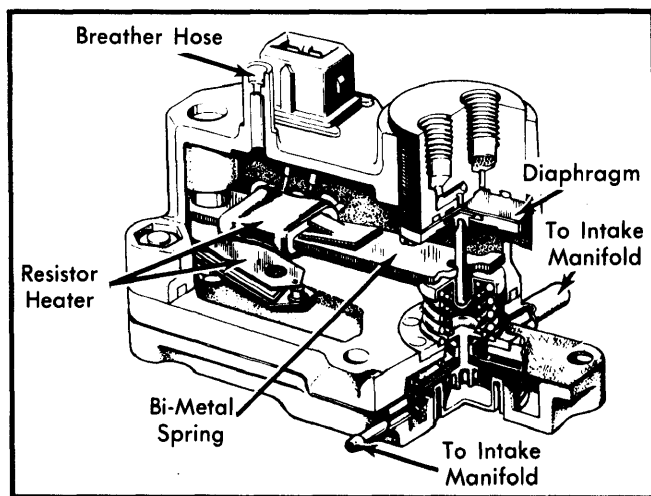

Fig. 2 Control Pressure Regulator
(Pressure Compensated Model – Others Similar)

AUXILIARY AIR VALVE

The auxiliary air valve, or regulator, provides additional air to the engine to increase idle speed when the engine is cold. It allows air to by-pass the throttle valves which are closed at idle. A heating coil in the valve is connected to the control pressure regulator and fuel pump circuit. As the coil warms up, it gradually closes the air passage. The valve is calibrated to keep idle smooth without a large speed change as the engine is warming up.

COLD START VALVE

The cold start valve is located in the intake manifold and sprays fuel during starting. It enriches the mixture so the engine will start easily. The valve is powered through the starter circuit and grounded through the thermo-time switch so it operates for only a short time while the engine is being cranked.

THERMO-TIME SWITCH & HOT START RELAY

The thermo-time switch is affected by coolant or block temperature and starter current. Depending on engine temperature, the switch will take from 3-10 seconds to open. Injection through the cold start valve will then stop. Some models use a hot start pulse relay to improve hot starting. The relay will operate the cold start valve in short pulses after it would normally have been turned off by the thermo-time switch.

INJECTOR NOZZLES

The injectors in the CIS system open at a predetermined pressure. Fuel is always present in the lines between the fuel distributor and the injectors, to ensure good starting. As pressure in the distributor increases (when the engine is started), the valves open and spray constantly. The amount of fuel injected will be determined by the position of the control plunger and control pressure.

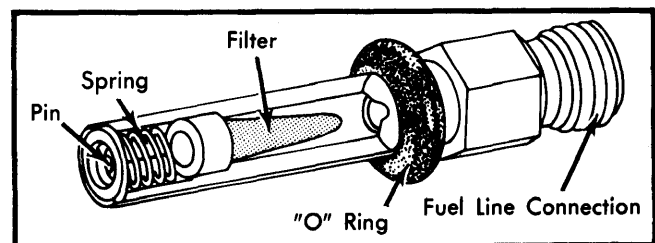

Fig. 3 Bosch CIS Lambda Injection Nozzle

FUEL PUMP

An electric fuel pump is used to provide fuel pressure of about 60-80 psi (4.1-5.5 kg/cm²). An accumulator and check valve operate to maintain pressure in the system when the engine is not running, to aid in starting. The fuel pump is controlled by a relay to prevent it from continuing to operate if the engine stalls. It can be wired in several ways, the most common being through a switch on the air flow sensor or through a coil energized by the ignition system. When testing the system, the safety relay must be bypassed.

OXYGEN SENSOR

The oxygen sensor is located in the exhaust manifold and measures the amount of unburned oxygen in the exhaust gas. If oxygen is low (rich mixture) a high voltage will be generated by the sensor. If oxygen is high (lean mixture) the voltage will be low. The signal from the oxygen sensor goes to an electronic control unit which determines engine mixture.

BOSCH LAMBDA CIS INJECTION SYSTEM – ALL MODELS (Cont.)

ELECTRONIC CONTROL UNIT & FREQUENCY VALVE

The electronic control unit is designed to continually correct the air/fuel mixture, based on signals from the oxygen sensor. It sends a series of pulses to a frequency valve. The frequency valve is located in a fuel line that connects the upper and lower halves of the fuel distributor.

When the frequency valve is closed, fuel pressure to the injectors is determined by a spring in each pressure regulating valve. When the frequency valve is open, fuel pressure decreases in the lower half of the fuel distributor, the tension on the spring is relieved, and more fuel goes to the cylinders.

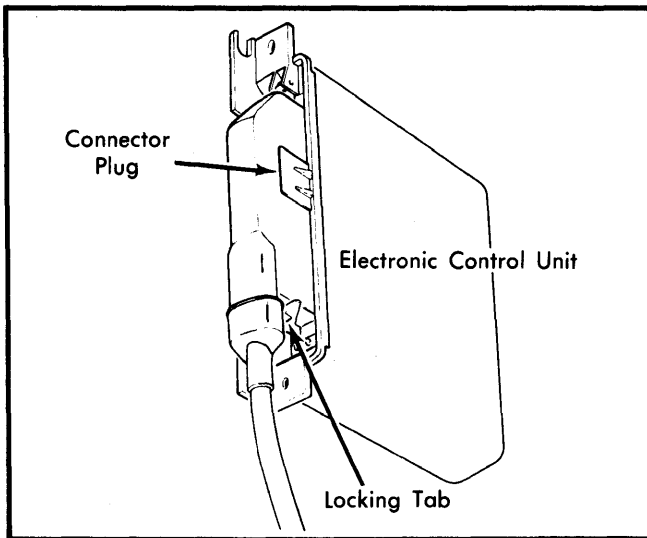

Fig. 4 Bosch CIS Lambda Electronic Control Unit

The electronic control unit opens and closes the frequency valve many times a second to ensure a smooth regulation of fuel pressure and mixture. When the engine is cold, the ratio of valve open to valve closed is about 50%. After the engine warms up, the voltage produced by the oxygen sensor determines the amount of time the frequency valve must be open or closed. This ratio can be read with a special tester or with a dwell meter (on most models). A dwell reading of 45° indicates a ratio of 50% open, 50% closed.

CATALYTIC CONVERTER

CIS Lambda systems can control air/fuel ratios within .02%. This close regulation allows the use of a 3-way catalyst that can decrease NOx, HC, and CO emissions. The converter can be damaged by improper adjustment of the system or by the use of leaded fuels.

TESTING

NOTE – Testing procedures described below will apply to all models using the CIS Lambda system unless otherwise noted. Not all models will use all components.

PREPARATION FOR TESTING

1) All CIS systems are very sensitive to air leaks. Check condition of rubber boots, hoses, and gaskets. Other areas of leakage are injectors, cold start valve, and PCV system (filler cap and dipstick).

2) A pressure gauge must be installed to perform fuel pressure tests. On all models, pressure gauge is installed between the control pressure regulator and the center fitting on fuel distributor.

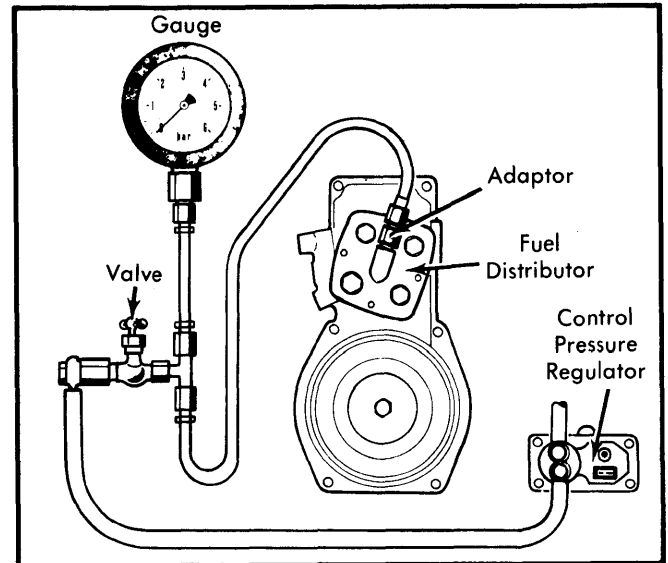

Fig. 5 Pressure Gauge Installation

3) To operate fuel pump with engine off, disconnect fuel pump relay from relay panel (VW, Porsche, Audi, Saab, Mercedes Benz). Insert a jumper wire into sockets that correspond to terminals 30 and 87 on relay. On Peugeot, remove steering wheel and lower left dash panel. Install switch and harness (8.0141 P) to tachymetric relay connector, or jumper across 30 and 87B. On Volvo, Mercedes-Benz, and other models so equipped, disconnect safety switch connector on air flow sensor.

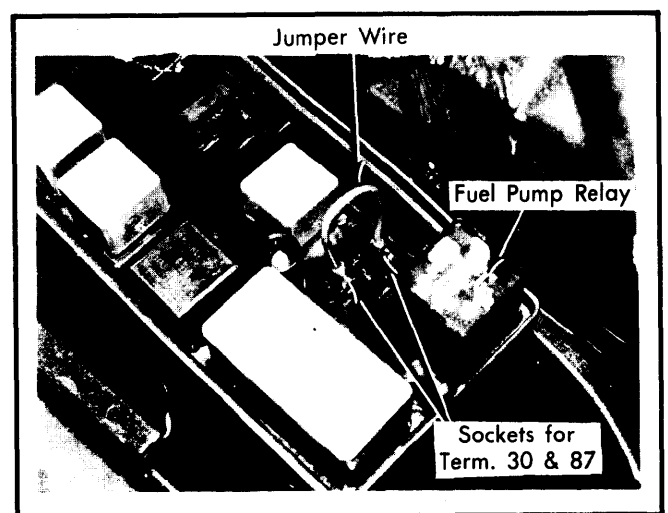

Fig. 6 Fuel Pump Jumper Wire For Testing (Saab Shown, Others Similar)

4) Turn ignition on. Place pressure gauge as low as possible in engine compartment. then open and close valve 5 times to bleed gauge. Place valve in open position and hang in convenient location. Turn pump off.

BOSCH LAMBDA CIS INJECTION SYSTEM – ALL MODELS (Cont.)

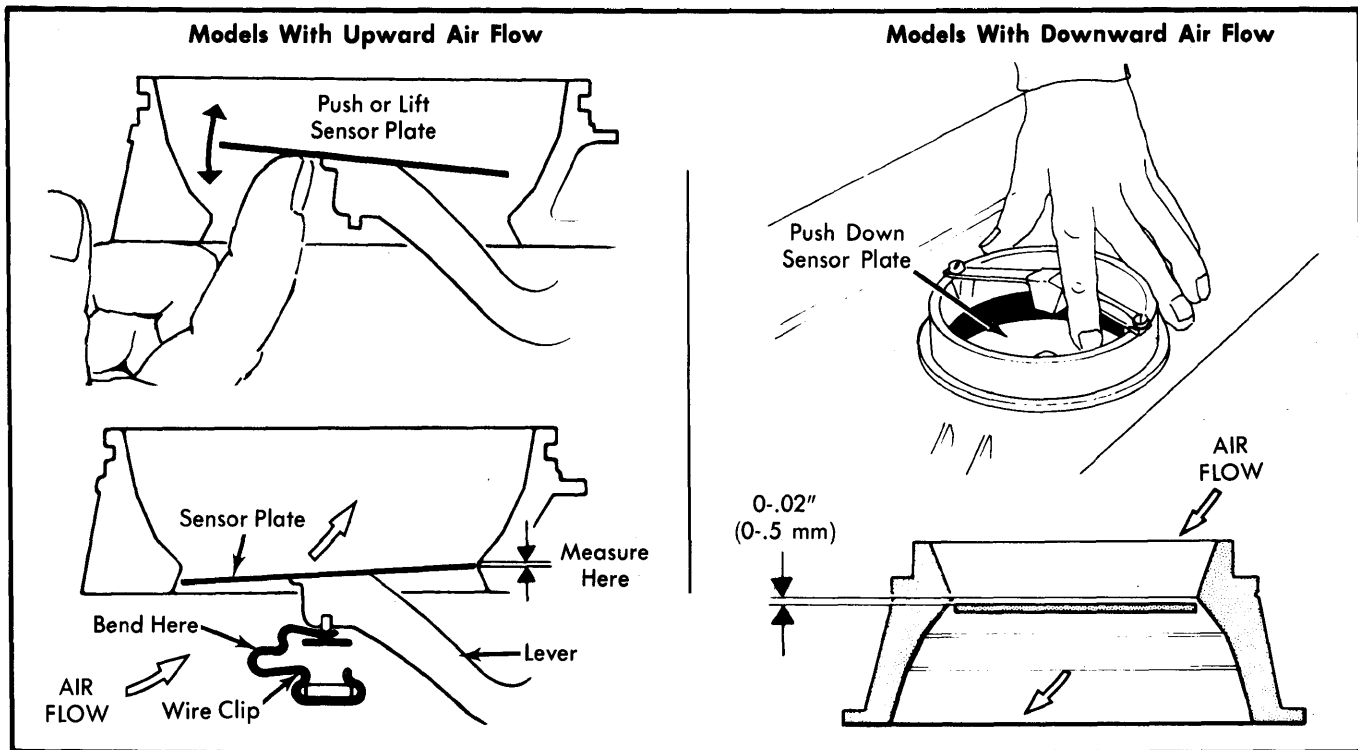

Fig. 7 Checking Air Flow Sensor Operation and Alignment

AIR/FUEL MIXTURE CONTROL (AIR FLOW SENSOR)

1) Remove rubber bellows to expose plate in sensor. Disconnect electrical connectors on auxiliary air valve and control pressure regulator, then operate fuel pump for ten seconds to build up control pressure.

NOTE – Directions given for moving sensor plate apply to engines where sensor plate moves UP with air flow. Reverse directions if servicing an engine where air flow moves DOWN.

2) Lift sensor plate slowly with magnet or pliers. Resistance due to control pressure should be constant throughout range of plate. Release plate slowly, lever and control piston should follow.

3) Lift plate, then return it rapidly to lower position. The piston moves more slowly and should be heard hitting the lever. If not, control piston is sticking. Remove 3 screws from fuel distributor and lift off of air flow sensor housing. Be careful not to drop control piston.

4) Clean plunger in gasoline. Remove any deposits with finger nail; DO NOT use tools. Slide plunger in and out while turning it. If any sticking or binding is felt, replace fuel distributor.

5) Reinstall fuel distributor. Check air flow sensor plate alignment. Plate should be even with bottom rim or 0.02" (0.5 mm) lower. If not, bend spring to correct, or reposition stop pin (tap lightly with punch).

6) Plate should be centered in housing. If not, loosen center screw and align plate with 0.004" (0.1 mm) feeler gauge at four points around rim. Apply Loctite and tighten screw.

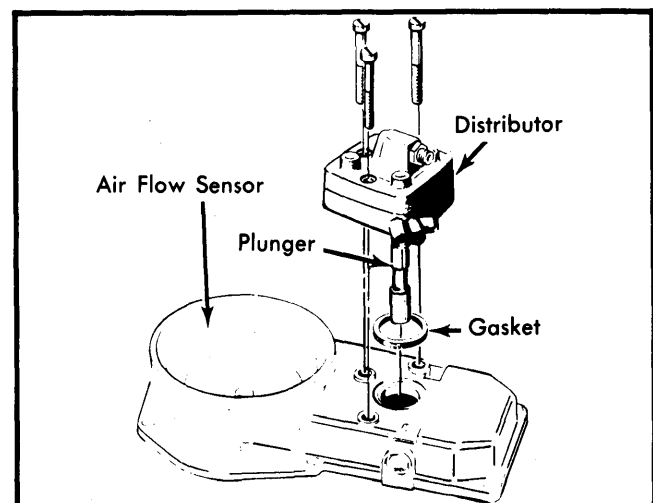

Fig. 8 Checking Fuel Distributor Plunger

COLD ENGINE CONTROL PRESSURE TEST

1) Testing must be done on cold engine. Unplug connectors at auxiliary air valve and control pressure regulator. Place valve on pressure gauge in open position and operate fuel pump.

2) Check pressure quickly. Reading should fall in shaded area of graph. Be sure to check air temperature and read correct area of graph.

3) If control pressure is not correct, retest with new control pressure regulator. No servicing is possible.

NOTE – Some models have a control pressure regulator with atmospheric pressure compensation. Pressures may vary slightly on these models.

BOSCH LAMBDA CIS INJECTION SYSTEM – ALL MODELS (Cont.)

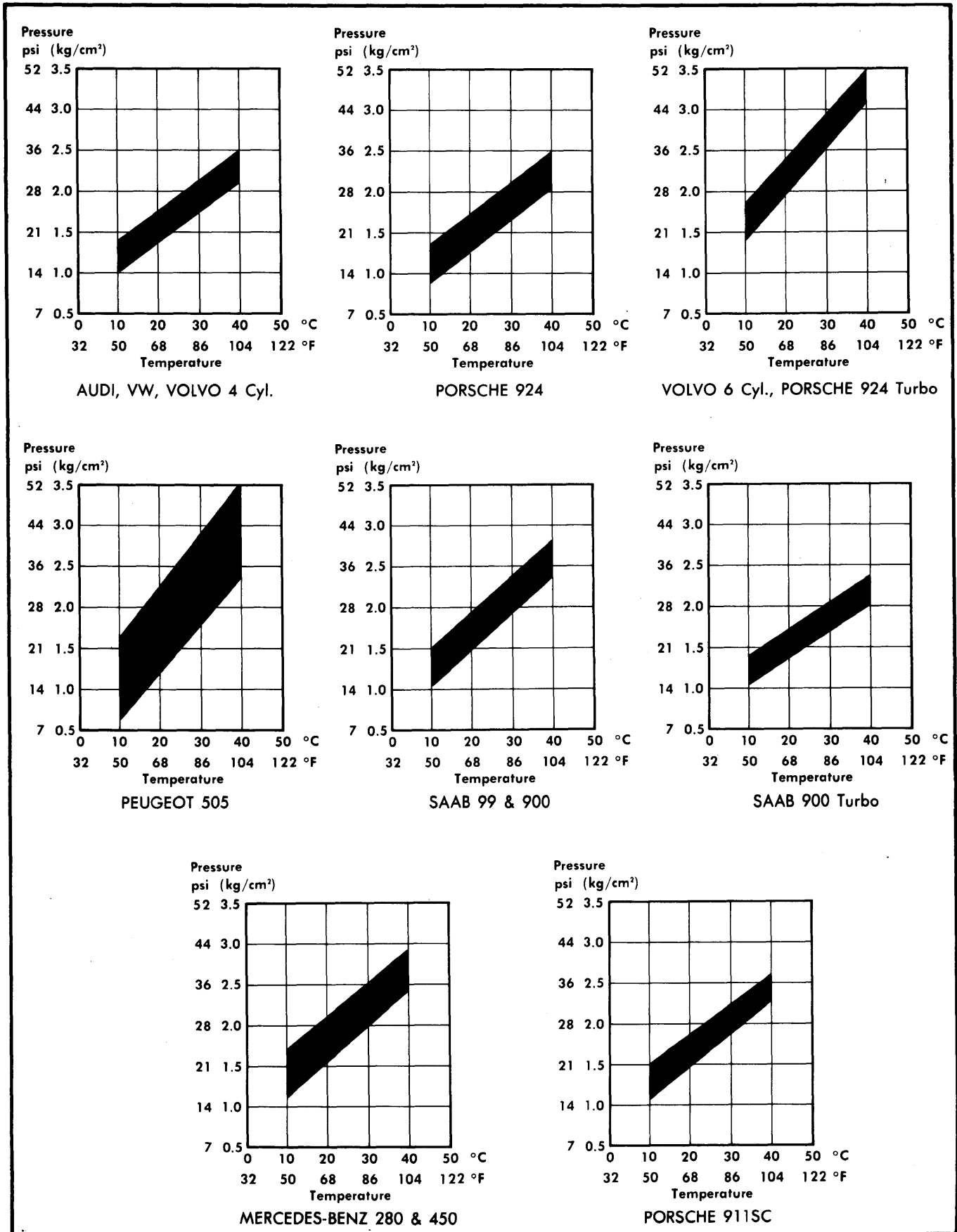

Fig. 9 Cold Engine Control Pressure Test Graphs

1980 Bosch Fuel Injection

BOSCH LAMBDA CIS INJECTION SYSTEM – ALL MODELS (Cont.)

WARM ENGINE CONTROL PRESSURE TEST

1) Connect plug to control pressure regulator. Leave auxiliary air valve and air flow sensor (if equipped) plugs disconnected. Place valve for pressure gauge in open position and operate fuel pump.

2) After about 5 minutes, pressure should rise to level indicated in "Pressure Testing" chart. On models with vacuum hose connected to control pressure regulator, leave hose connected to read pressure.

3) Start engine and allow to idle. Pressure should remain the same or rise slightly. On models with control pressure regulator vacuum line, remove and plug hose. Pressure should drop.

4) If pressure does not reach level specified, disconnect plug at control pressure regulator. Check for voltage across terminals with test lamp or voltmeter. At least 11.5 volts should be present. If not, check wiring. If voltage is present and pressure not correct, replace control pressure regulator.

SYSTEM (LINE) CONTROL PRESSURE TEST

1) Close valve on pressure gauge. With engine off, operate fuel pump. Pressure should rise to level specified in "Pressure Testing" chart.

2) If pressure is too low, check fuel pump output. Disconnect fuel return line from fuel distributor and run a hose from fuel distributor to container. Operate fuel pump and measure output after 30 seconds. If not as specified in "Fuel Pump Flow" chart, check fuel lines, filter, accumulator and pump.

3) If pressure is too high, check for kinked or blocked fuel return line. If lines are clear, system pressure regulator must be adjusted. Turn pump off, loosen return line fitting, and relieve pressure.

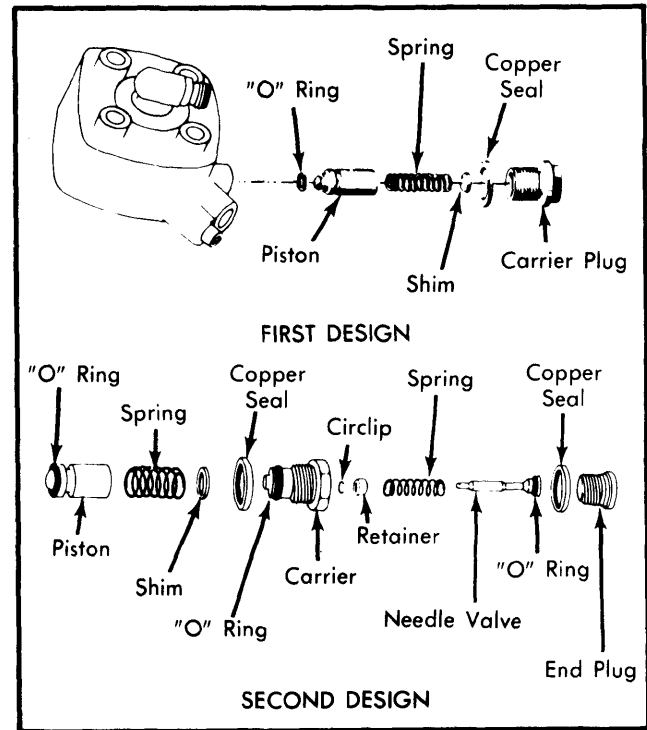

Fig. 10 Pressure Regulator in Fuel Distributor

4) Loosen line pressure regulator nut. Remove shims, spring(s) and plunger. Raise system pressure by adding shims; lower pressure by removing shims. Be sure "O" rings are in good condition. If plunger is scored or damaged, fuel distributor must be replaced.

Fuel Pump Flow Specifications

Application	Flow in 30 Sec. oz. (cc)
BMW, Peugeot, Porsche	24 (750)
Audi, Saab, VW	30 (900)
Mercedes-Benz	32 (1000)

FUEL INJECTION PRESSURE TESTING

Application	Line Pressure psi (kg/cm ²)	Warm Control Pressure psi (kg/cm ²)	Rest Pressure psi (kg/cm ²)	Nozzle Opening Pressure psi (kg/cm ²)
Audi 5000 Turbo	72-81 (5.0-5.6)	49-55 (3.4-3.8)①	23-37 (1.6-2.6)	38-53 (2.7-3.7)
Audi 4000, 5000	64-74 (4.5-5.2)	49-55 (3.4-3.8)	23-37 (1.6-2.6)	41-59 (2.9-4.1)
BMW 320i	64-75 (4.5-5.2)	49-55 (3.4-3.8)	24 (1.7)	44 (3.1)
Mercedes-Benz	72-81 (5.0-5.6)	49-55 (3.4-3.8)①	36-41 (2.5-2.8)	43 (3.0)
Peugeot 505	64-75 (4.5-5.2)	49-55 (3.4-3.8)	38-39 (2.6-2.7)	43-59 (3.0-4.1)
Porsche 911SC	64-75 (4.5-5.2)	38-44 (2.7-3.1)	②	②
Porsche 924	64-75 (4.5-5.2)	49-55 (3.4-3.8)	21-24 (1.5-1.7)	36-52 (2.5-3.6)
Porsche 924 Turbo	78-87 (5.4-6.0)	49-55 (3.4-3.8)③	14 (1.0)	38-55 (2.7-3.8)
Saab	64-75 (4.5-5.2)	49-55 (3.4-3.8)	24-34 (1.7-2.4)	43-59 (3.0-4.1)
Volkswagen	64-75 (4.5-5.2)	49-55 (3.4-3.8)	23-37 (1.6-2.6)	46-54 (3.2-3.8)
Volvo 4 Cyl.	64-75 (4.5-5.2)	50-56 (3.5-3.9)	24-34 (1.7-2.4)	37-51 (2.6-3.6)
Volvo 6 Cyl.	64-75 (4.5-5.2)	45-49 (3.1-3.4)	24 (1.7)	37-51 (2.6-3.6)

- ① Vacuum connected.
- ② Not available.
- ③ No vacuum applied.

BOSCH LAMBDA CIS INJECTION SYSTEM – ALL MODELS (Cont.)

REST PRESSURE & LEAK TEST

- 1) After correct warm engine control pressure has been obtained, stop fuel pump and note pressure drop. Valve should be in open position. Minimum pressure after 20 minutes must be as specified in "Pressure Testing" chart.
- 2) If pressure drops too rapidly, run pump again and close valve. Stop pump and observe pressure. If values are now correct, control pressure regulator is faulty and must be replaced.
- 3) If pressure still drops, check all connections, fuel pump check valve, cold start valve, and fuel injectors.

COLD START VALVE, THERMO-TIME SWITCH & HOT START PULSE RELAY

- 1) If engine coolant is below 85°F (30°C), disconnect plug on cold start valve and connect test lamp across terminals. Remove coil high tension wire to prevent starting. Operate starter.
- 2) On models without hot start pulse relay, test lamp will light for several seconds, then go out. On models with relay, lamp will continue to flash off and on.
- 3) If lamp does not light, test thermo-time switch for continuity below opening temperature. If good, check wiring to starter terminal.
- 4) Remove cold start valve from manifold but leave fuel line connected. Place valve in a container. Connect a jumper wire from one terminal to ground, and from other terminal of cold start valve to a switch. The other side of switch should be connected to battery voltage.

CAUTION — Do not connect wire directly to battery. Extreme fire danger is present due to atomized fuel. Sparks may result if wire is touched to battery.

- 5) Operate fuel pump. Turn switch to "ON" position. Cold start injector should spray. Turn switch "OFF", but leave fuel

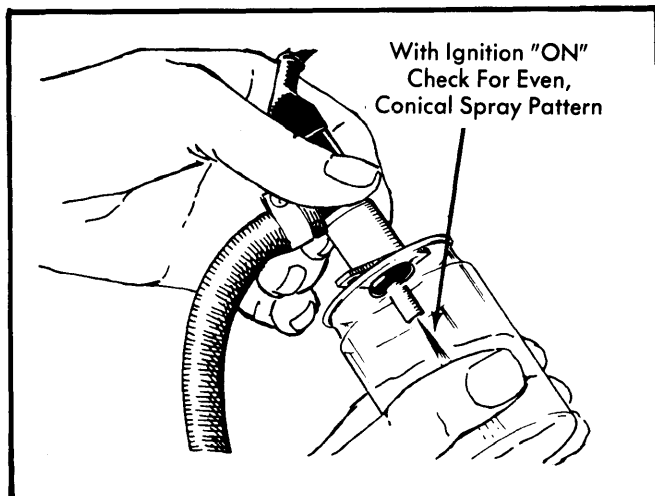

Fig. 11 Testing Cold Start Injector Valve

pump running. Injector should not spray. Wipe off nozzle and check for leakage. With pump running, no drops should form within one minute.

- 6) Replace cold start valve if faulty. Reinstall original valve if good, making sure that "O" ring is properly positioned.

FUEL INJECTORS

- 1) Remove injectors but leave hoses connected. Place injectors in individual measuring containers. Operate fuel pump to build up pressure, then turn pump off.
- 2) Lift air flow sensor plate half-way to operate injectors until one container has filled to 3.4 oz. (100 cc). Other container volume should not vary more than 10-20°.
- 3) If one injector is outside specifications, swap hoses from it and one good injector at fuel distributor and retest. If same container is low, injector is faulty. If other container is low, fuel distributor must be replaced.
- 4) Relieve system pressure and remove pressure testing gauge. Turn on pump to build up pressure. Injectors may leak slightly, but no drops should form in less than 15 seconds. If drops form, check air flow sensor plate height, sticking fuel distributor plunger, or injector opening pressure.

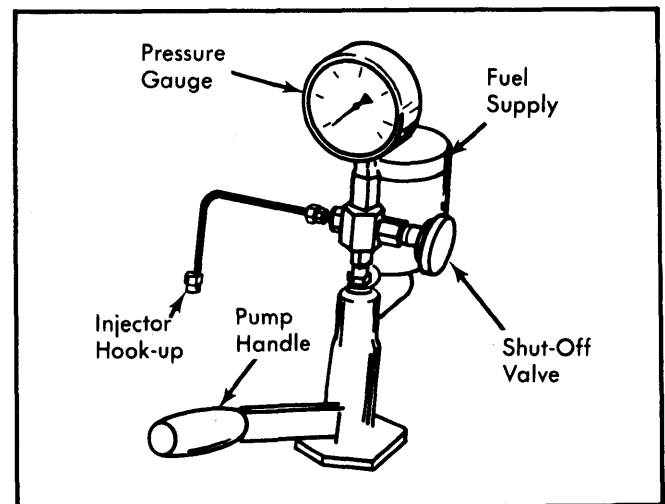

Fig. 12 Fuel Injector Tester

- 5) Remove injectors from vehicle and use injector tester to determine opening pressure. Check specifications in "Pressure Testing" chart and replace injectors if faulty.

AUXILIARY AIR VALVE

- 1) Disconnect hoses from auxiliary air valve. Shine a light through valve. At room temperature, valve should be slightly open. Turn ignition "ON" (disconnect wires from air flow sensor, if equipped) and see that opening is closed in less than 5 minutes. Tap valve slightly to assist in closing.

BOSCH LAMBDA CIS INJECTION SYSTEM – ALL MODELS (Cont.)

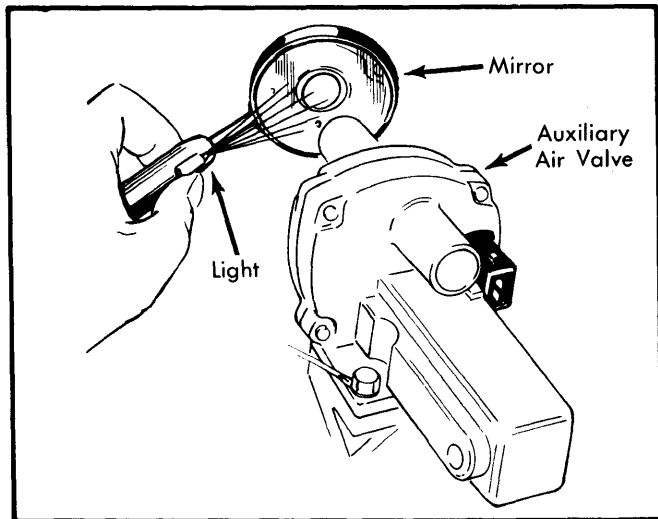

Fig. 13 Checking Auxiliary Air Valve Operation

2) If valve does not operate properly, check for power at connector with engine running. Connect a test lamp across connector terminals. If lamp does not light, check fuse and wiring. If lamp lights, check resistance of auxiliary air valve. If no resistance is measured, valve is bad. If resistance is measured, clean terminals and make sure connection is good.

LAMBDA CONTROL SYSTEM CHECKS

PREPARATION FOR CHECKS

NOTE — The frequency valve is operated by a pulsating voltage from the electronic control unit. By measuring this signal, certain functions of the system can be tested. A special tester (Bosch KDJE 7453) is recommended, but a high quality dwell meter may be used instead. A voltmeter is used for Mercedes-Benz.

1) Connect dwell meter to testing connector. Connector is located on left side near windshield washer container on Peugeot, beside brake booster on Volvo, and to left of fuse and relay panel on Saab. Connector is behind throttle valve housing on Volkswagen and Audi. Set meter on 4-cyl. scale.

2) On Mercedes-Benz, remove cap from diagnostic plug connector (rear of left fender panel). Connect positive lead of voltmeter to battery and negative lead to pin 3 of diagnostic plug. Start engine and run until warm. Disconnect oxygen sensor and observe needle (should not fluctuate). Place a piece of tape on meter face to indicate 50% position.

OPERATION CHECK

1) Remove fuel pump relay and connect jumper wire across sockets corresponding to terminals 30 and 87. If equipped, remove plug at air flow sensor. Turn ignition "ON".

2) Frequency valve should operate, making a buzzing noise. Dwell meter should indicate 45-65°. Disconnect wire from oxygen sensor and touch wire end to ground. Readings on dwell meter should rise. Ground one end of a 1.5 volt flashlight battery, and touch positive end to sensor wire. Readings should drop to less than 15°.

3) On models with throttle enrichment switch, operate throttle. Readings should be higher at idle or wide open throttle. See wiring diagram for enrichment switches used.

4) If engine is cold, enrichment switches will be closed. Disconnect lead at temperature sender. Readings should drop slightly. If engine is hot, connect temperature sender lead to ground. Reading should rise. See wiring diagram for enrichment switches used.

5) If starter enrichment relay is used, disconnect high tension lead at coil and crank engine. Readings should rise above normal level. If vacuum switches are used, apply vacuum to switch and note readings. Level should be higher with switch closed, and lower with switch open.

6) Connect oxygen sensor and start engine. With cold engine, dwell reading should be stable. When engine warms up, meter needle should fluctuate 10-20°. It may be necessary to run engine faster than idle to heat oxygen sensor and cause needle fluctuation.

7) Connect a CO meter to exhaust test point. With oxygen sensor disconnected, reading should be stable on dwell meter. Note CO%. With sensor lead grounded, reading should rise and CO% increase. With lead connected to flashlight battery, reading and CO% should decrease.

8) If dwell reading does not rise with sensor grounded, check sensor wiring (see "Electrical Testing"). If wiring is good, replace control unit. If dwell rises, but CO% does not, check frequency valve and wiring (see "Electrical Testing"). Replace if necessary.

9) If dwell does not decrease with battery connected to sensor lead, check sensor wiring and replace control unit if wires are good. If dwell decreases but CO% does not, check frequency valve wiring and replace valve if wiring is good.

10) Adjust CO% to rich level (3%) with oxygen sensor still disconnected. Reconnect sensor. Reading should drop at least 1%. If not, replace oxygen sensor.

ELECTRICAL TESTING

NOTE — Electronic control unit is located under dash near fuse panel on Porsche 924. It is near glove box on Audi, BMW, Peugeot and Volkswagen. Control unit is behind right kick panel on Mercedes-Benz and Volvo, and beneath right seat on Porsche 911SC and Saab.

1) Locate electronic control unit and press locking tabs back to disconnect connector. All connectors are wired with pin numbers in the same location. Use a high-quality volt-ohm-meter for testing.

BOSCH LAMBDA CIS INJECTION SYSTEM – ALL MODELS (Cont.)

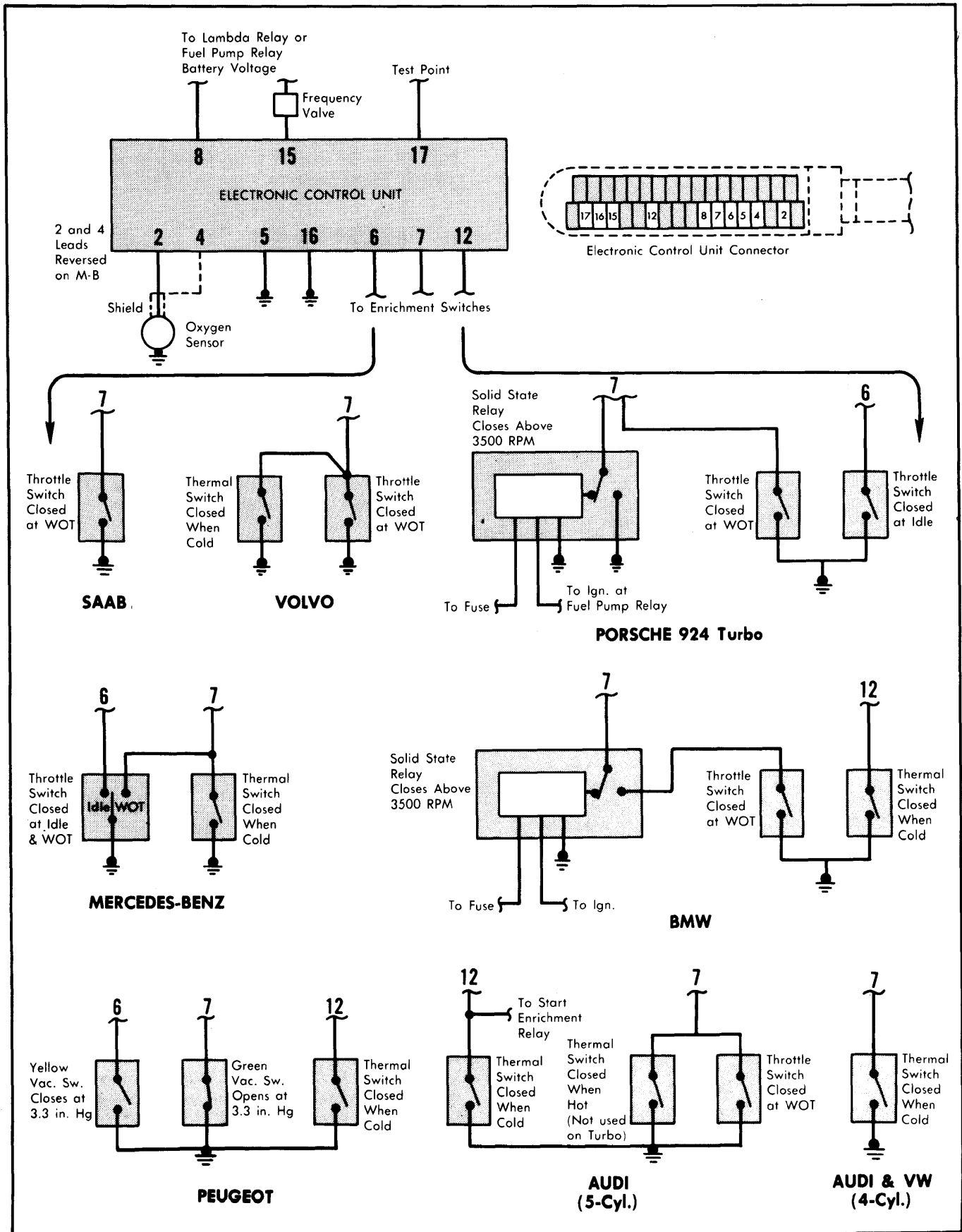

Fig. 14 Bosch CIS Lambda Electronic Control Unit Wiring Diagram
 Copyright (c) 2001 Mitchell Repair Information Company

BOSCH LAMBDA CIS INJECTION SYSTEM – ALL MODELS (Cont.)

2) Refer to wiring diagram for pin locations. With ignition "ON" and fuel pump jumper wire in place, check for battery voltage at terminals 8 and 15. Connect ground lead of voltmeter to terminals 5 and 16 while checking for battery voltage to ensure these wires make a good ground connection.

3) If battery voltage is not available at terminal 8, check Lambda and fuel pump relays. If no voltage at 15, check frequency valve connector. One wire should have battery voltage; the other wire should have continuity to terminal 15. Frequency valve should have 2-3 ohms resistance. Repair or replace as necessary.

4) Disconnect oxygen sensor and check for continuity between sensor lead and terminal 2 (4 on Mercedes-Benz). No continuity should exist between ground and lead wire.

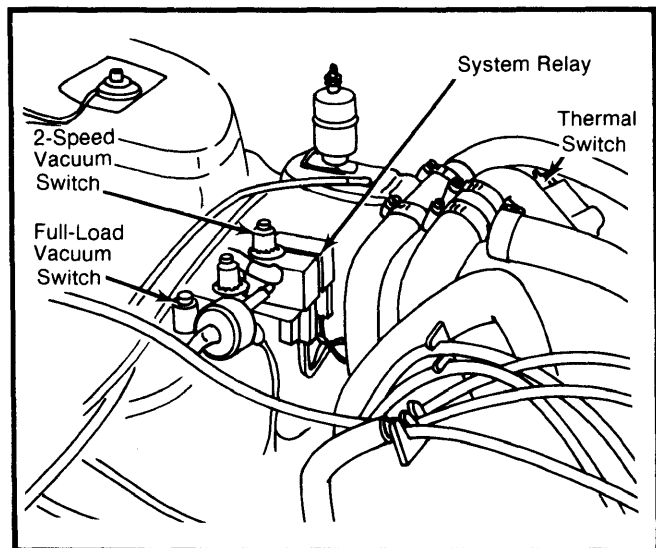

Fig. 15 Peugeot Enrichment Vacuum Switches

5) All models use enrichment switches. All switches provide continuity to ground when switch is closed. Actuate throttle to test throttle switches. Apply vacuum to switches to test vacuum enrichment switches on Peugeot. Thermal switches can be checked by removing switch and heating in water. Repair wiring or replace switches as necessary.

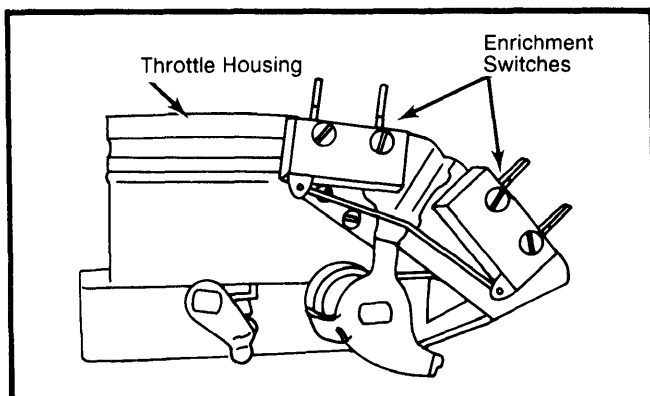

Fig. 16 Throttle Enrichment Switches (Porsche 924 Turbo Shown)

6) After testing is completed, reconnect electronic control unit, oxygen sensor, and all switches. Remove fuel pump relay jumper wire and testing equipment.

REMOVAL & INSTALLATION

CAUTION — On all models, disconnect battery and relieve fuel pressure before removing component parts.

MIXTURE CONTROL UNIT

1) Clean around all fuel line connections. Remove fuel lines and wipe up any spilled fuel. Disconnect electrical wiring and remove rubber boot to manifold. Remove Allen screws and lift off mixture control unit.

2) To install, reverse removal procedure. Replace gaskets and seals and check for leaks after installation.

FUEL DISTRIBUTOR

1) Remove mixture control unit. Remove 3 screws from top of fuel distributor. Lift off carefully, ensuring that plunger does not fall out of distributor.

2) Only pressure regulator shims may be exchanged. If plunger or piston is scored, replace fuel distributor. Be sure "O" ring is in place and in good condition when replacing unit.

CONTROL PRESSURE REGULATOR

Disconnect electrical plug and vacuum lines (if equipped). Remove fuel lines and wipe up any spilled fuel. Remove bolts and regulator. To install, reverse removal procedure.

AUXILIARY AIR VALVE

Remove and plug hoses. Disconnect electrical plug. Remove mounting bolts and air valve. Reverse removal procedure to install.

COLD START VALVE

Remove electrical connector and fuel line. Loosen mounting bolts and remove cold start valve. Check "O" ring and replace if necessary when reinstalling valve.

FUEL INJECTORS

1) Clean area around valves. On BMW, remove intake cowl and pipes at number 2 and 3 cylinders. Hold valve and remove fuel line fitting. Do not allow valve to turn.

2) Remove retaining plate if present, and pull valves out carefully. Do not remove insulator sleeve if possible.

3) To install, reverse removal procedure. Replace "O" rings and lubricate with a drop of oil. Place injectors in sleeve and press until seated. Tighten fuel lines and check for leaks.

BOSCH LAMBDA CIS INJECTION SYSTEM – ALL MODELS (Cont.)

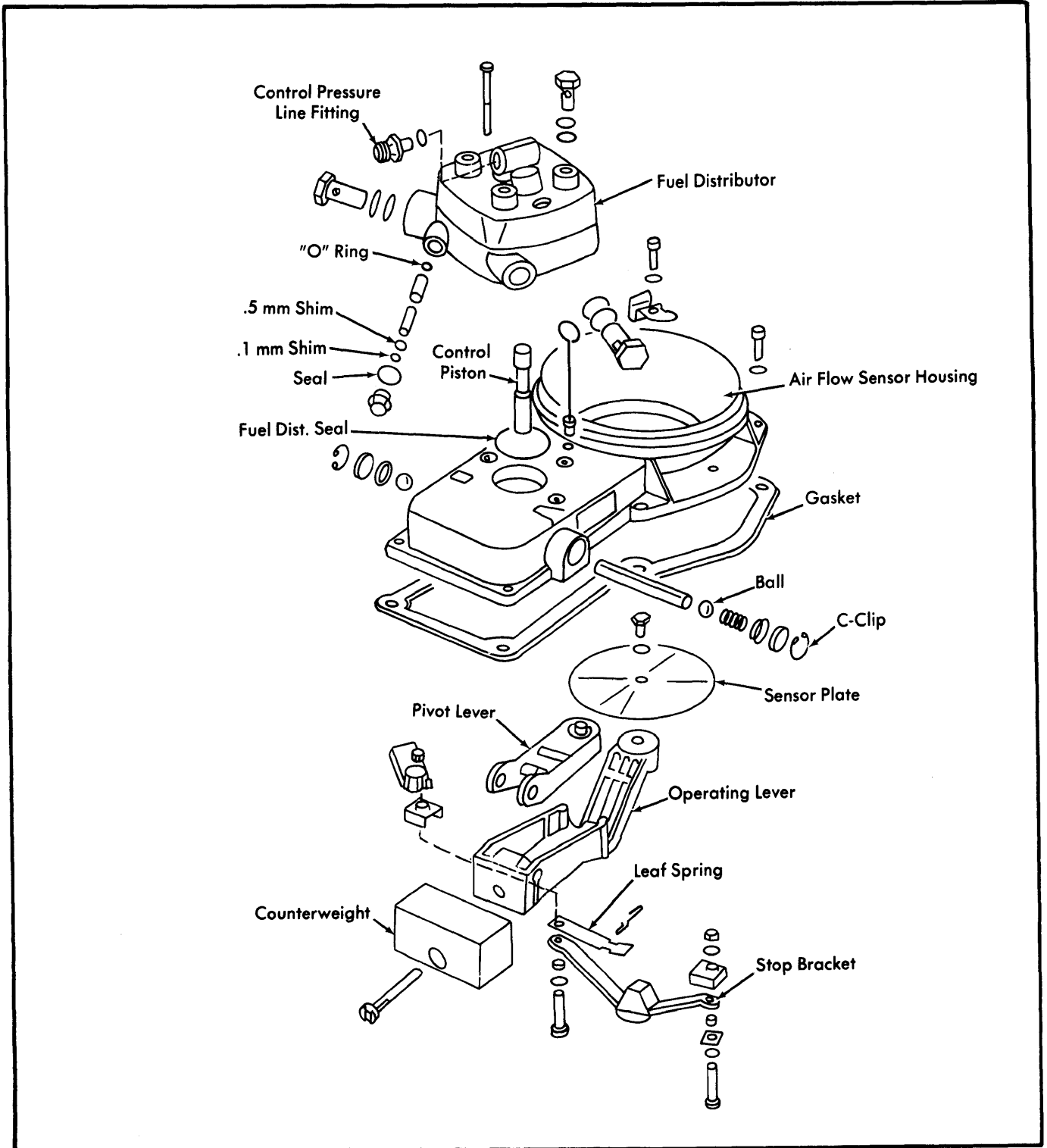

Fig. 17 Exploded View of Mixture Control Unit for Porsche 924 Model

BOSCH LAMBDA CIS INJECTION SYSTEM – ALL MODELS (Cont.)

THERMAL SWITCH

Drain coolant below level of switch. Be careful not to damage connectors on switch while removing. Coat threads of sensor with sealant and reinstall.

FREQUENCY VALVE

1) Disconnect electrical connector. Hold small nut at hose and loosen larger valve nut. Do not spill gasoline on rubber mounting insulator as it will cause the rubber to swell.

2) Remove return lines at fuel distributor and/or control pressure regulator. To install, reverse removal procedure, installing new gaskets. Check for leaks after installation.

ELECTRONIC CONTROL UNIT

Porsche 911SC and Saab – Slide passenger seat rearward (Saab) or remove from vehicle (Porsche). Remove cover from plug and disconnect plug. Remove 3 mounting fasteners and remove control unit. Reverse removal procedure to install.

Mercedes-Benz and Volvo – Pull back carpeting or trim on right kick panel. Remove cover and disconnect plug from control unit. Remove mounting bolts and control unit. To install, reverse removal procedure.

Peugeot – Remove glove box, support, and heater hose. Disconnect plug from control unit. Remove 2 nuts from mounting studs and remove control unit. To install, reverse removal procedure.

Volkswagen – Disconnect plug from control unit beneath glove box. Remove mounting bolts and control unit. To install, reverse removal procedure.

NOTE – Removal and installation procedures were not available for other models.

OXYGEN SENSOR

1) Disconnect wiring from sensor. On Porsche 911SC, remove left rear wheel and protector plate. Remove shield from sensor if equipped. Remove sensor.

2) Coat threads of new sensor with anti-seize compound. Take care not to get compound into slots on end of sensor. Install sensor and tighten to 25-30 ft. lbs. (3.5-4.1 mkg). Refit shield and connect sensor wire.

NOTE – For Oxygen Sensor Maintenance Light resetting procedure see appropriate manufacturer article in EXHAUST EMISSION SYSTEMS Section.