

## WEBER 32 DIR 2-BARREL

Renault  
Le Car

## DESCRIPTION

The Weber 32 DIR carburetor is a 2-barrel downdraft type. The carburetor base is heated by engine coolant flowing through it.

The California model has a fuel feedback system, a fast idle (throttle opener) system, a dashpot, idle cut-off, an electromagnetic vent cut-off valve and a cold start system (manual choke).

The Federal model has a throttle plate opener, an electromagnetic vent valve, idle cut-off and manual choke, but has no dashpot or fuel feedback system.

## CARBURETOR IDENTIFICATION

Application	Carb. No.
Renault Le Car	
Federal .....	32 DIR 82
Calif. ....	32 DIR 80

## ADJUSTMENTS

## HOT (SLOW) IDLE RPM

See appropriate Tune-Up article in TUNE-UP section.

## IDLE MIXTURE

See appropriate Tune-Up article in TUNE-UP section.

## COLD (FAST) IDLE RPM

See appropriate Tune-Up article in TUNE-UP section.

## FLOAT LEVEL &amp; FLOAT DROP (TRAVEL)

**California Models** - 1) Hold the fuel bowl top vertically with its gasket in place, so that the float weight closes the needle without pushing the ball inward.

2) Check dimension between bowl gasket and float, float level dimension "A" in Fig. 1, against specifications. To adjust bend float arm "1" until inner tab "2" resting against needle, is perpendicular to needle. Tab "3" should permit float travel, dimension "B", as noted in specifications.

**Federal Models** - 1) Remove float bowl and hold top in vertical position. See Fig. 2. Allow weight of float to close needle without allowing ball to enter valve.

2) Measure dimension "A" in Fig. 2 to check float level. If necessary, adjust by bending float arm. Measure dimension "B" for float drop or travel. If necessary, adjust by bending float tab.

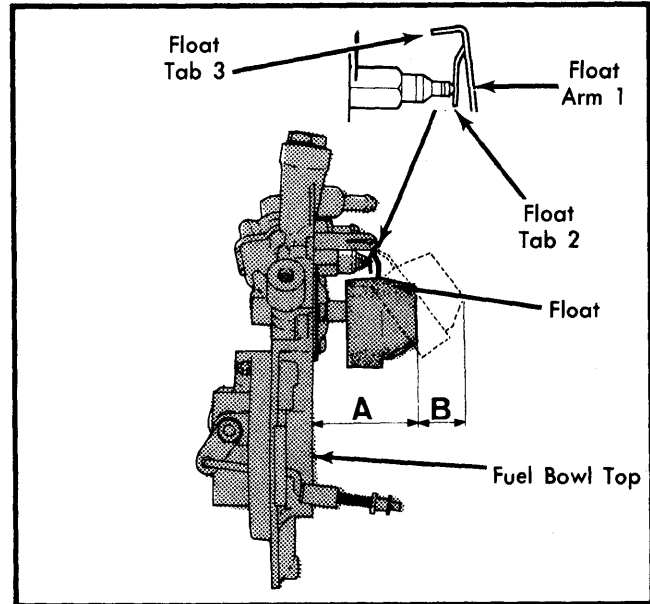

Fig. 1 Float Level and Drop (Travel) Adjustment (California Models)

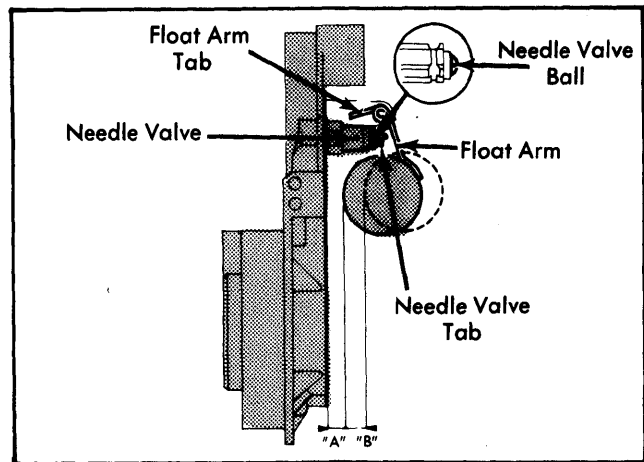

Fig. 2 Float Level and Drop (Travel) Adjustment (Federal Models)

## INITIAL THROTTLE VALVE OPENING ADJUSTMENT

1) Put choke lever in cold start position. Measure initial opening of first barrel throttle, using feeler gauges (MS 787).

2) To adjust, remove plastic cap and turn adjusting screw until specification is reached. See Fig. 3. After adjustment, tighten lock nut (if equipped) and install new plastic cap over adjusting screw.

**NOTE** - To remove brass cap, drill a .118" (3 mm) hole and insert screw in hole and lift off.

## WEBER 32 DIR 2-BARREL (Cont.)

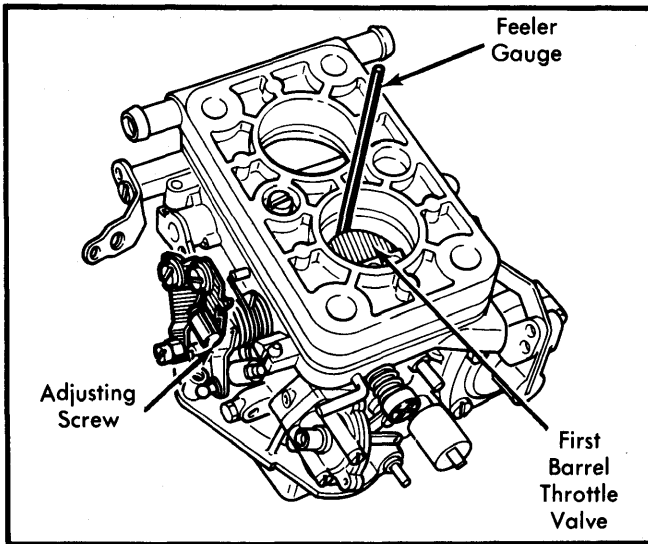

**Fig. 3 Initial Throttle Valve Opening Adjustment (California Model Shown)**

### INITIAL CHOKE VALVE MECHANICAL OPENING ADJUSTMENT

With choke valve fully closed, push on sleeve until it contacts cam lever. Measure opening at bottom of choke valve. Measurement should be as noted in specifications. If adjustment is needed, bend link as shown in Fig. 4.

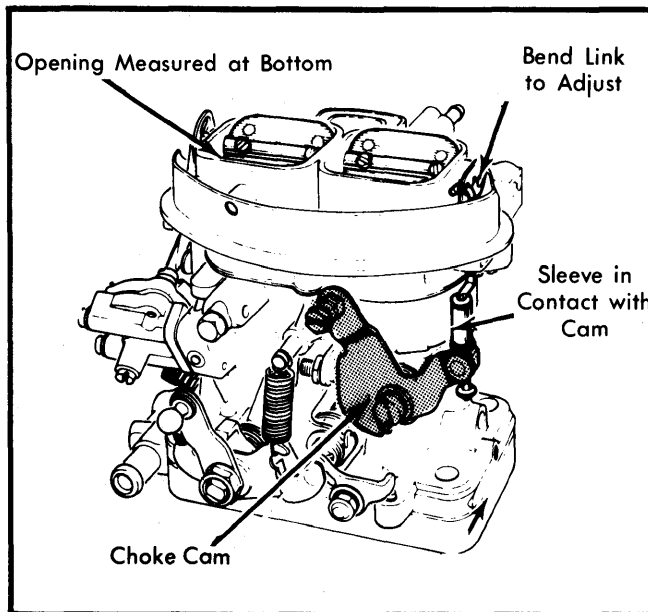
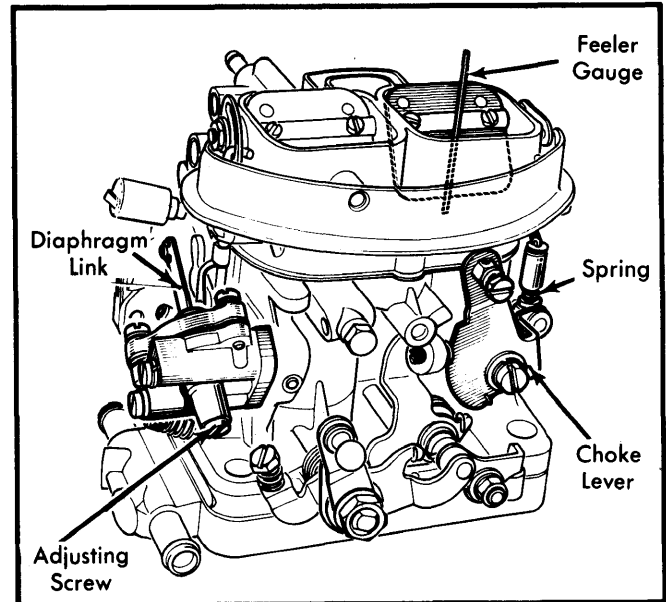

**Fig. 4 Initial Choke Valve Mechanical Adjustment (Federal Model Shown)**

### INITIAL CHOKE VALVE VACUUM OPENING ADJUSTMENT

**California Models** — 1) Place choke lever in cold start position. Push in diaphragm link until it is against stop. Measure initial opening of choke valve on the large section side. See Fig. 5. Measure at bottom of valve.

2) Remove brass cap from adjusting screw. Turn screw, as necessary, to obtain specified valve vacuum opening.



**Fig. 5 Initial Choke Valve Vacuum Adjustment (California Model Shown)**

**NOTE** — To remove brass cap, drill a .118" (3 mm) hole and then insert a screw in cap hole and lift off.

**Federal Models** — 1) Push diaphragm link in as far as possible. Now close choke valves with choke lever until spring on link is slightly compressed. Measure opening at bottom of choke valve.

2) Measurement should be as specified. If adjustment is needed, remove screw from end of diaphragm and turn set screw until choke valve vacuum opening is correct.

### DASHPOT ADJUSTMENT (CALIFORNIA MODELS ONLY)

1) Install .059" (1.5 mm) feeler gauge as shown in Fig. 3 to maintain the initial opening of the first barrel throttle plate.

2) Cut plastic cover off dashpot assembly to gain access to adjustment screw. See Fig. 6. Position dashpot so that it just contacts the throttle lever. Install new cover, and lock it in place by driving pin in dashpot bracket hole provided for locking purposes.

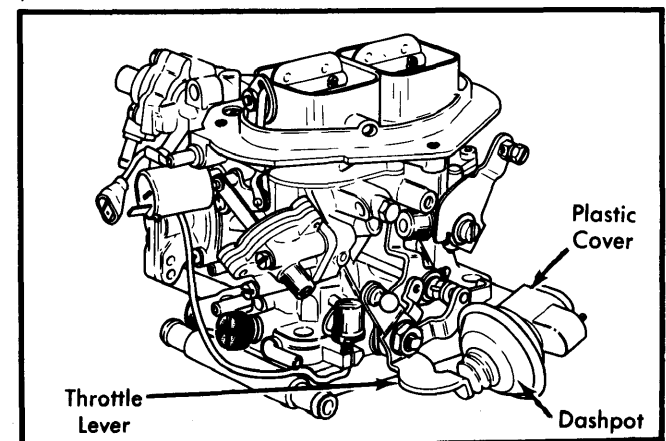

**Fig. 6 Dashpot Adjustment (California Only)**

# 1980 Weber Carburetors

## WEBER 32 DIR 2-BARREL (Cont.)

CARBURETOR ADJUSTMENT SPECIFICATIONS								
Carb. No.	Idle Speed (Engine RPM)		Float Level Setting In. (mm)	Float Drop Setting In. (mm)	Choke Plate (Vacuum) In. (mm)	Choke Plate (Mech.) In. (mm)	Unloader Setting In. (mm)	Vacuum Break In. (mm)
	Hot	Fast						
Federal (DIR 82)	675-725 <sup>⓪</sup>	.....	.276 (7.0)	.315 (8.0)	.393 (10.0)	.236 (6.0)	.....	.....
Calif. (DIR 80)	700-800	.....	1.50 (38.0)	.315 (8.0)	.354 (9.0)	.25 (6.5)	.....	.....

<sup>⓪</sup> - 700-800 RPM with air injection