

# 1974-79 DISTRIBUTORS & IGNITION SYSTEMS 4-57

## Mitsubishi Electronic Ignition

**Chrysler Corp.: 1979 Models**  
**Ford Motor Co.: 1979 Courier**  
**Mazda: 1976-77 808 (1300cc Federal)**  
**1977-78 GLC Federal**  
**1979 B2000, GLC, 626**

### DESCRIPTION

Mitsubishi transistorized breakerless ignition consists of an electronic control module (ignitor), ignition coil and distributor. On some models, the control module was mounted with the ignition coil, on left fender apron. See Fig. 1. On others, such as Chrysler and late 1979 Courier 2000cc engines, it was mounted on the outside of the distributor housing. See Fig. 2.

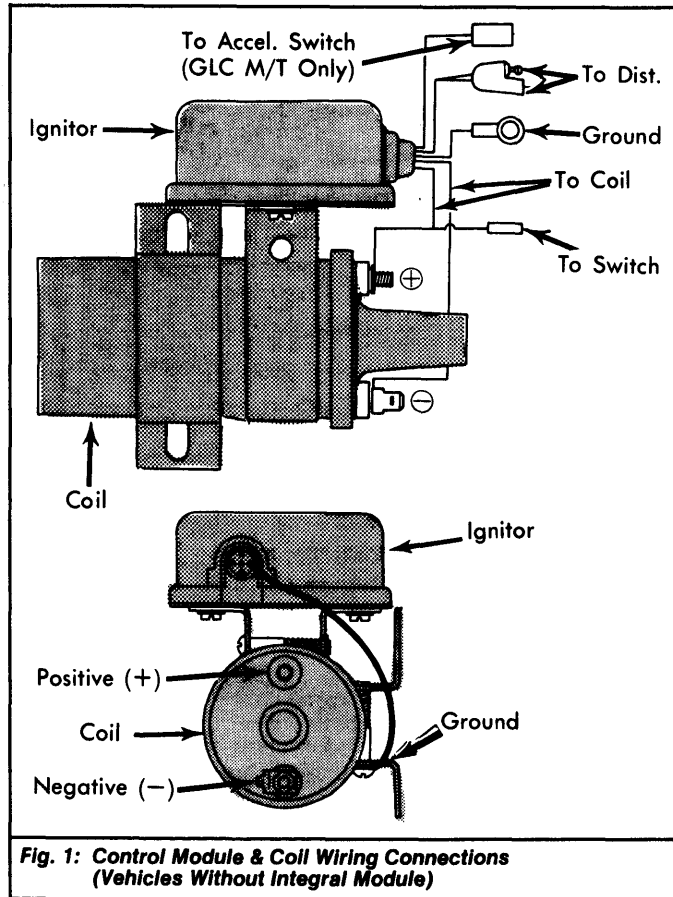

**Fig. 1: Control Module & Coil Wiring Connections (Vehicles Without Integral Module)**

### OPERATION

Whenever ignition is on, the primary circuit of the ignition coil is energized. As the distributor shaft rotates, the armature (reluctor) rotates inside the magnetic pick-up coil (stator) assembly. See Fig. 2. As the teeth of the armature pass the pegs of the pick-up coil and breaker plate assembly, a signal is sent to the control module (ignitor). The module then breaks the primary circuit in the coil, inducing high voltage in the secondary circuit firing the spark plugs.

### SPECIFICATIONS

#### CENTRIFUGAL & VACUUM ADVANCE

See appropriate DISTRIBUTOR ADVANCE SPECIFICATIONS table in this section.

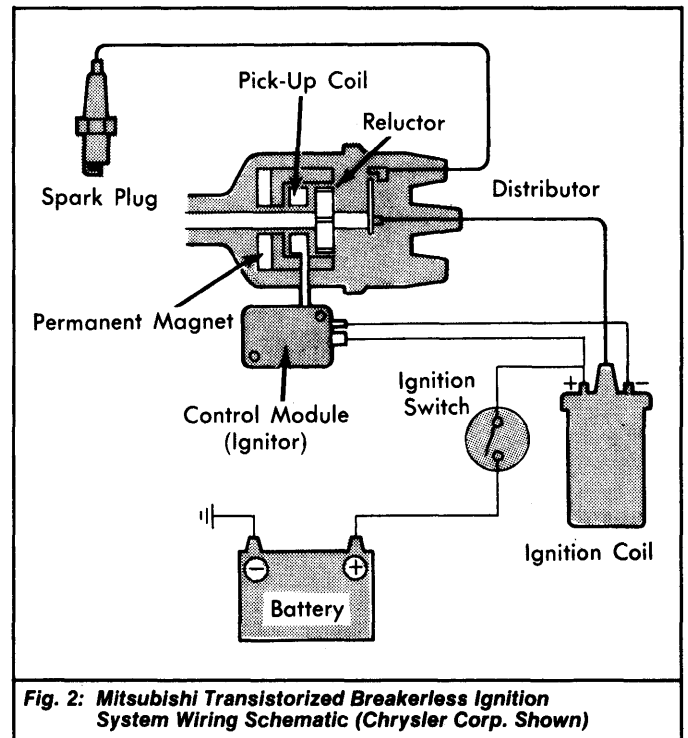

**Fig. 2: Mitsubishi Transistorized Breakerless Ignition System Wiring Schematic (Chrysler Corp. Shown)**

### ADJUSTMENTS

#### PICK-UP COIL AIR GAP

Align teeth of armature (reluctor) with pegs of pick-up coil and breaker plate assembly. Using feeler gauge, check air gap. If gap is not to specifications, bend pick-up coil on Courier. On Mazda vehicles, loosen set screws and move pick-up coil until correct gap is obtained.

**NOTE: Air gap is not adjustable on Chrysler Corp. or late model Courier 2000cc engines.**

#### PICK-UP COIL AIR GAP

Application	In. (mm)
1976-78 Models	.010-.014 (.25-.36)
1979 Models	.008-.024 (.20-.61)

### TESTING

#### HIGH VOLTAGE TEST

**Chrysler Corp.** - 1) Remove distributor cap and remove rotor assembly. Turn ignition on. Disconnect coil wire from distributor cap and hold wire end 1/4" (6 mm) from engine block.

2) Insert a screwdriver between armature (reluctor) and magnetic pick-up coil. See Fig. 3. If a spark is produced, suspect a defective control unit, pick-up coil assembly, ignition coil or secondary cables.

**Other Models** - Connect remote starter switch in starting circuit and remove coil wire from distributor cap. Turn ignition on and hold coil wire 1/4" (6 mm) from engine block. Crank engine. If no spark or a weak spark results, perform the following tests.

#### IGNITION COIL RESISTANCE TEST

1) Turn ignition off. Set ohmmeter on low scale and attach its leads to coil positive and negative terminals. Coil should be isolated from rest of system. Check primary resistance reading.

2) Set ohmmeter in x1000 scale and attach leads to positive primary terminal and secondary tower. Check secondary resistance reading. Replace coil if not to specifications.

# 4-58 1974-79 DISTRIBUTORS & IGNITION SYSTEMS Mitsubishi Electronic Ignition (Cont.)

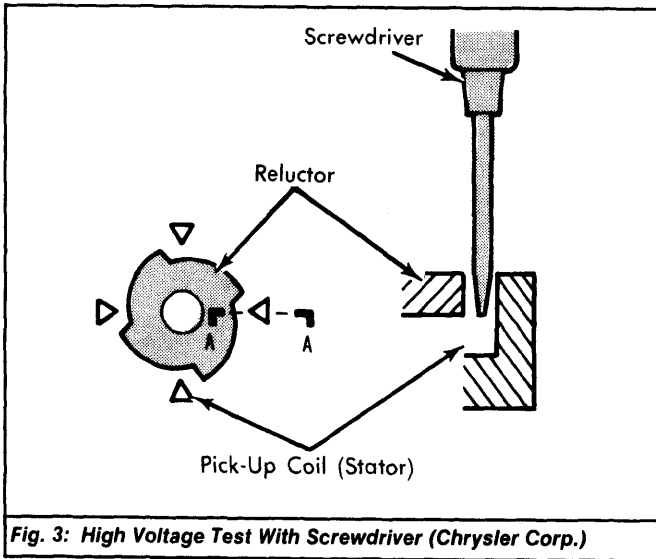

## IGNITION COIL SPECIFICATIONS

Application	Primary Resistance (Ohms)	Secondary Resistance (Ohms)
Chrysler Corp. <sup>1</sup>	.70-.85	9000-11,000
Courier	.81-.99	6800-9200
Mazda		
GLC & 808	1.28	13,500
626 & B2000	.81.99	7000

<sup>1</sup> - Resistance of external resistor should be 1.22-1.49 ohms.

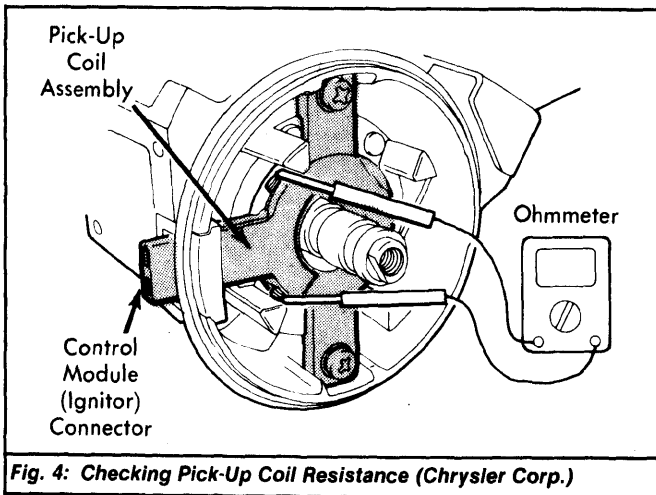

## MAGNETIC PICK-UP COIL RESISTANCE TEST

Set ohmmeter to the x100 scale and attach its leads to pick-up coil terminals. On Chrysler Corp. vehicles, connect ohmmeter leads as shown. See Fig. 4. Check magnetic pick-up coil resistance. Replace coil if not to specifications.

## MAGNETIC PICK-UP COIL SPECIFICATIONS

Application	Resistance (Ohms)
Chrysler Corp.	1000-1100
Courier (2000cc Engine)	1000-1100
Mazda	
GLC & 808	670-790
626 & B2000	720-880

## IGNITION MODULE TEST

**NOTE:** Mazda ignition module test not available at time of publication. Only the transistors in the switching section of the control module are evaluated by this test. The module may still be defective, even if control module checks okay. If control module checks okay, but system does not operate properly, substitute a known good module and attempt to start vehicle.

- 1) Connect test light (3.4 watts) to ignition coil positive and negative terminals. See Fig. 5. Attach one end of jumper wire to positive terminal. Disconnect distributor 2-pin connector.
- 2) Attach other end of jumper wire to Red wire terminal on module side of connector. Turn ignition on. Test light should come on. Test light should go out when jumper wire is disconnected.
- 3) If test light does not function as stated, retest to make sure bulb is okay and that all connections are tight. If results are still incorrect, replace control module and retest.

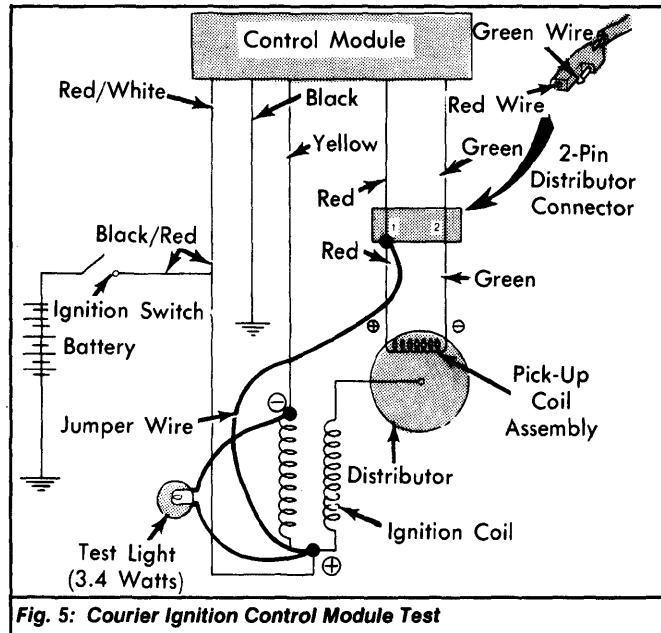

- 1) Using an ohmmeter, check for continuity between control module (ignitor) terminal "C" and its metallic surface. See Fig. 6. If module is installed on distributor, make check between terminal "C" and distributor housing.
- 2) Perform test in same manner as a diode test, alternately switching ohmmeter leads. If continuity or an open circuit exists in both directions, the control module is defective and must be replaced.

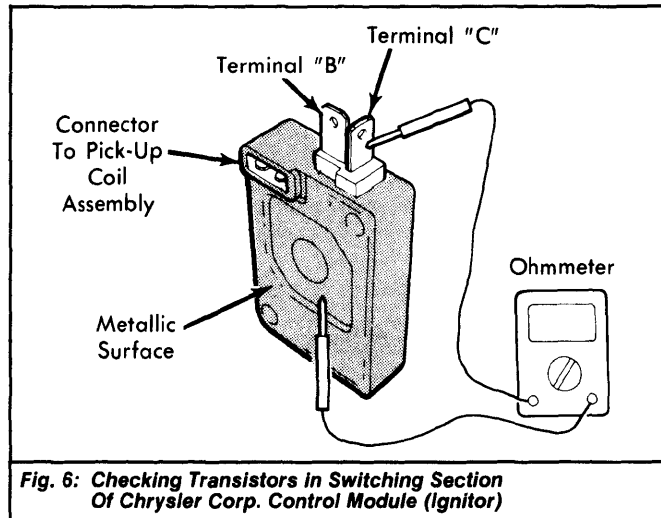

# 1974-79 DISTRIBUTORS & IGNITION SYSTEMS 4-59

## Mitsubishi Electronic Ignition (Cont.)

### SECONDARY WIRE RESISTANCE TEST

Test coil and spark plug cables with an ohmmeter. DO NOT puncture secondary wires when making resistance check. If secondary wire resistance is incorrect, replace wire(s).

### SECONDARY WIRE RESISTANCE SPECIFICATIONS

Application	Resistance (Ohms)
Courier .....	570 Per Inch
Chrysler Corp. ....	22,000 Per Cable
Mazda .....	16,000 Per Millimeter

## OVERHAUL

### DISASSEMBLY & REASSEMBLY

**Chrysler Corp.** - 1) Remove 2 screws and pull control module (ignitor) straight out. Unplug module from pick-up coil assembly. See Fig. 7. DO NOT remove silicone grease from module or distributor housing.

2) Remove distributor cap. Remove rotor assembly, governor assembly, and reluctor. Remove pick-up coil assembly. Remove vacuum control unit screws and "E" ring from vacuum link. Lift out vacuum control unit. Remove breaker assembly.

3) Remove roll pin securing driven gear. Remove plate and shaft from housing. Inspect cap and rotor for cracks and deposits on inside surfaces. Check driven gear for wear and shaft for play. Reassemble distributor in reverse order of disassembly.

**Courier & Mazda** - 1) Remove distributor cap and rotor. See Fig. 7 and 8. Remove cover, gasket and grommet. Remove clips. Drive roll pin from armature (reluctor) and remove armature.

2) Remove clip holding vacuum diaphragm link. Remove vacuum control unit. Remove pick-up coil assembly. Drive lock pin from driven gear and remove gear. Remove governor and shaft assembly from distributor housing.

3) Reassemble distributor in reverse order of disassembly. When installing cam, align marks on distributor housing and gear. Align rotor metal end with clip mounting lug on side of distributor with mounting slot.

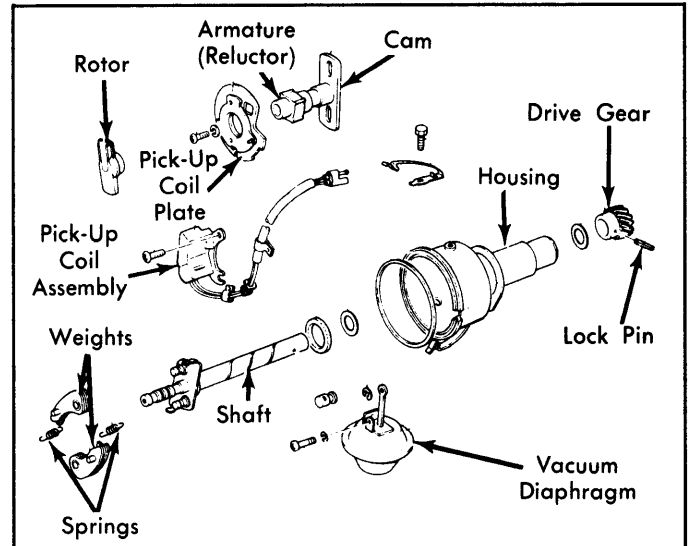

Fig. 8: Disassembled View Of Mazda GLC Distributor

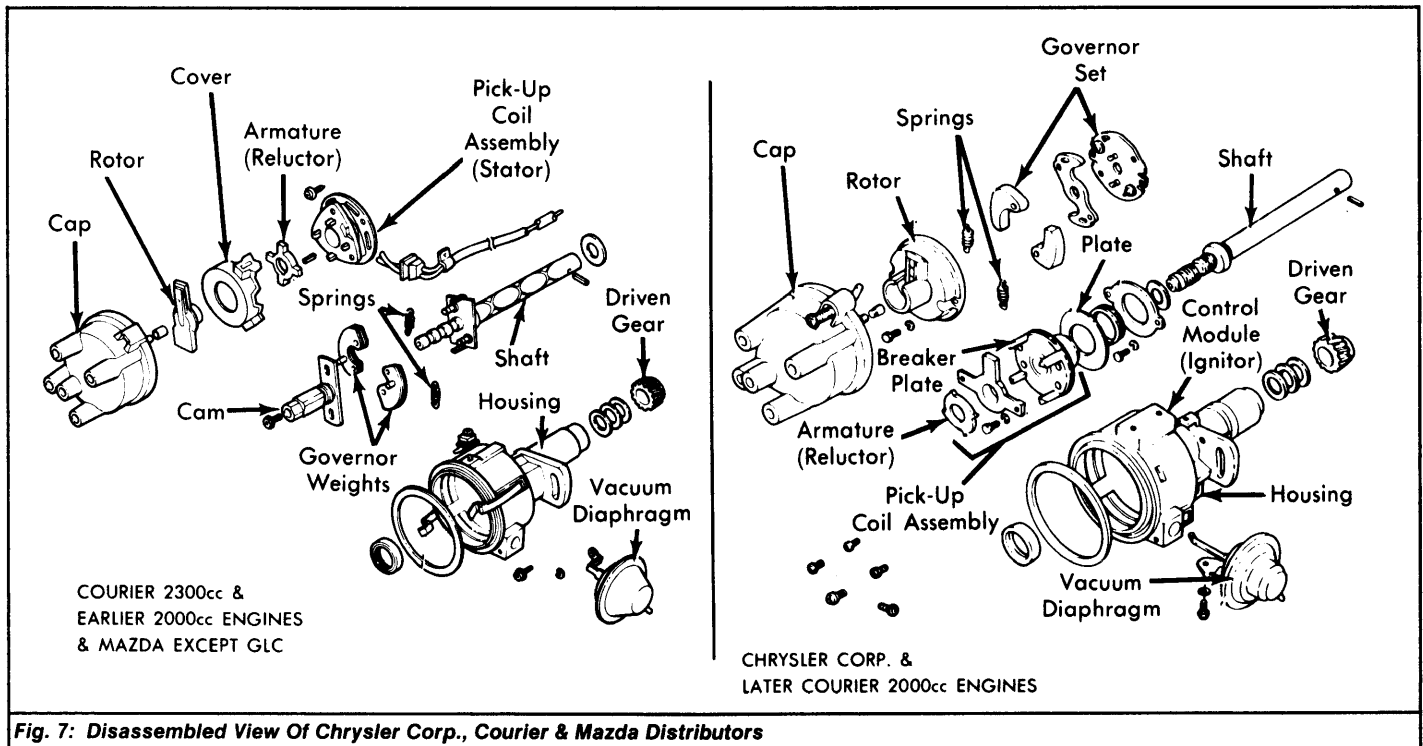

Fig. 7: Disassembled View Of Chrysler Corp., Courier & Mazda Distributors