

1974-79 DISTRIBUTORS & IGNITION SYSTEMS 4-45

Hitachi Single Breaker Point Distributors

Datsun: 1974-77 All Models (Exc. 280Z)
1976 280Z

General Motors: 1974-75 LUV

Honda: 1974-78 All Models
1979 Civic 1200, Civic CVCC

Subaru: 1974-75

DESCRIPTION

Hitachi single breaker distributors are equipped with centrifugal advance and vacuum advance/retard units. Breaker plate assembly consists of a fixed lower plate, with breaker points mounted on movable upper plate. Centrifugal advance is conventional type with weights and springs. Vacuum advance (or retard) is controlled by a vacuum diaphragm unit mounted on distributor housing and linked to movable portion of breaker plate assembly.

SPECIFICATIONS

POINT GAP & DWELL ANGLE

See appropriate article in TUNE-UP PROCEDURES section.

CENTRIFUGAL & VACUUM ADVANCE

See appropriate DISTRIBUTOR ADVANCE SPECIFICATIONS table in this section.

ADJUSTMENTS

POINT GAP & DWELL ANGLE

With rubbing block on high point of cam lobe, insert a feeler gauge blade between contacts and check reading against specification. To correct, loosen retaining screw and move stationary contact point until correct gap is obtained, then tighten screw. Align points if necessary by bending stationary contact support only. Compare dwell reading with specification and correct if necessary.

BREAKER ARM SPRING TENSION

Place hook end of spring scale as close as possible to the movable breaker point. Pull scale at a right angle (90 degrees) to the movable arm and note reading just as points begin to open.

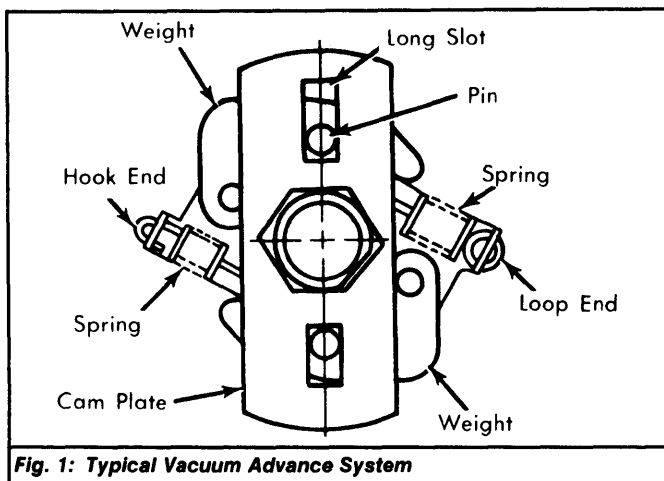

Fig. 1: Typical Vacuum Advance System

CENTRIFUGAL ADVANCE

Check distributor in a test stand according to test equipment manufacturer's instructions. Operate distributor up and down the RPM range and check advance at all RPM settings specified.

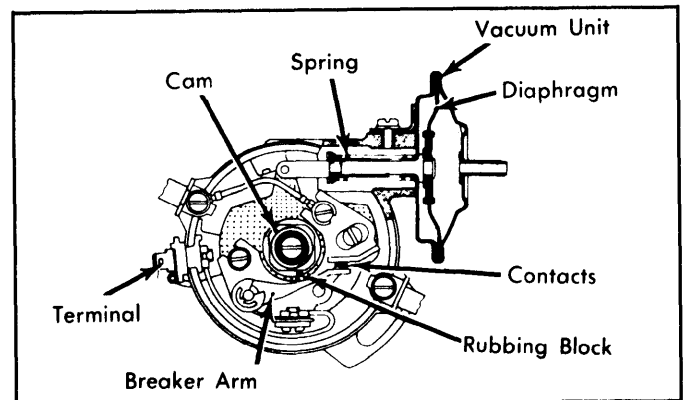

Fig. 2: Typical Centrifugal Advance

VACUUM ADVANCE

With distributor in test stand, check advance (or retard) at vacuum settings shown in specifications. If tests indicate vacuum diaphragm unit is inoperative, out of calibration, or leaking, replace vacuum unit.

OVERHAUL

DISASSEMBLY

Disassemble distributor using illustration as a guide. See Fig. 3. Mark position of driven gear (or coupling) on shaft for reassembly reference. Note position of cam, springs and weights on distributor shaft.

REASSEMBLY

To assemble, reverse disassembly procedure. When reassembling cam, governor weights and springs to shaft, be sure to attach spring with loop end to governor weight. Attach the spring with rectangular hook end to governor weight.

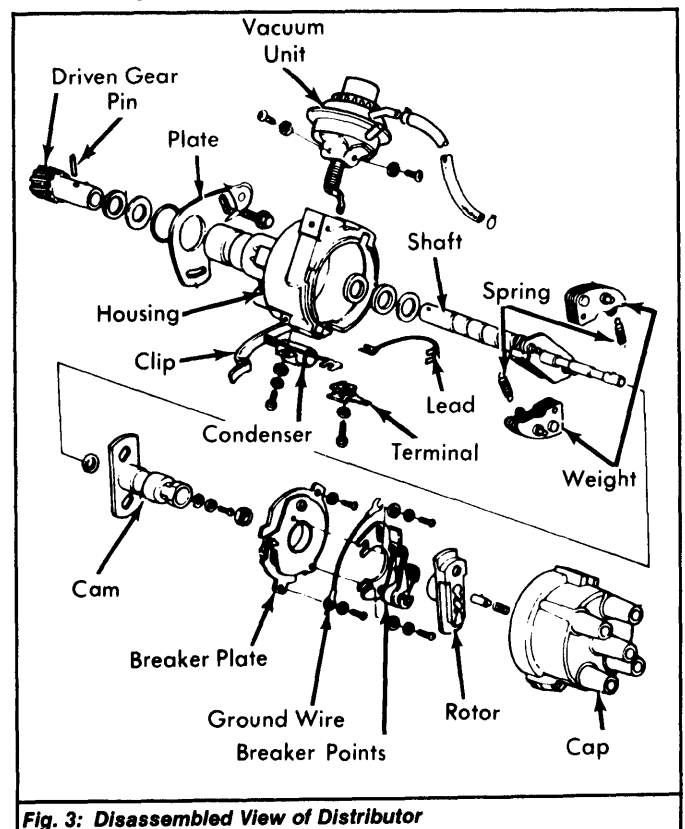

Fig. 3: Disassembled View of Distributor