

1974-79 DISTRIBUTORS & IGNITION SYSTEMS 4-43

Hitachi Electronic Ignition

DESCRIPTION

The Hitachi electronic ignition consists of a housing, rotor and distributor cap. See Fig. 1. A reluctor, mounted on the shaft and governor assembly, combines with the pick-up coil to replace the conventional cam and breaker points.

With the ignition on, the distributor reluctor rotates past the pick-up coil. As each tooth of the reluctor approaches and passes the pick-up coil, a signal is sent to the ignition control unit. The control unit then turns the primary circuit in the ignition coil on and off as each tooth passes the pick-up coil.

This switching causes a build-up and collapse of a magnetic field in the coil, resulting in a high voltage surge in the coil's secondary circuit. This high voltage surge fires the spark plugs. See Fig. 2.

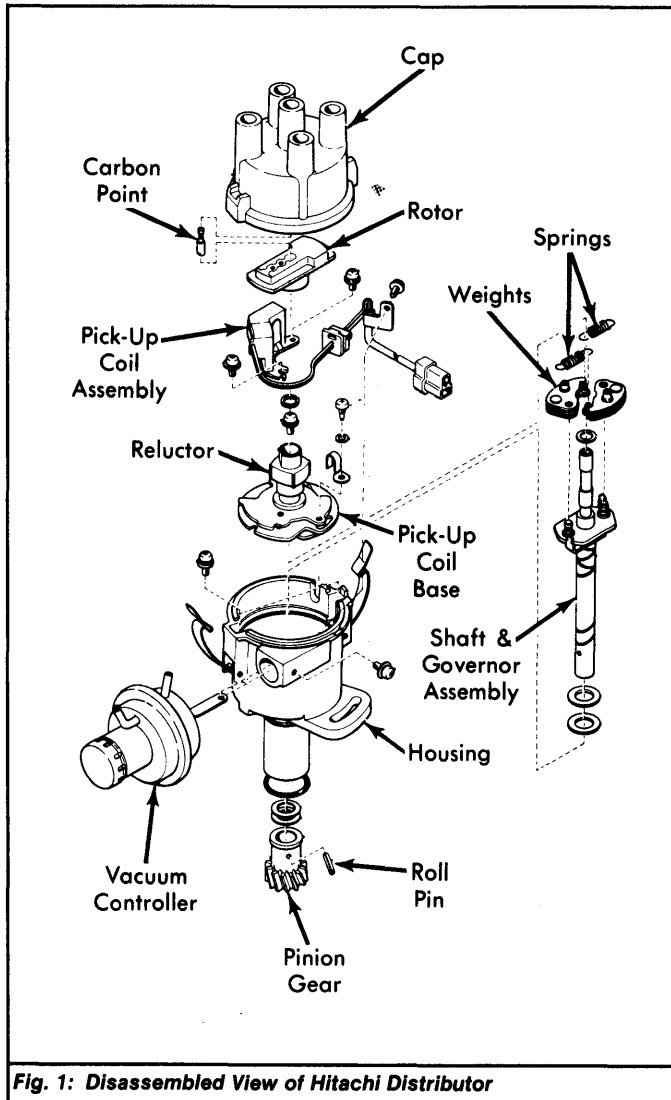

Fig. 1: Disassembled View of Hitachi Distributor

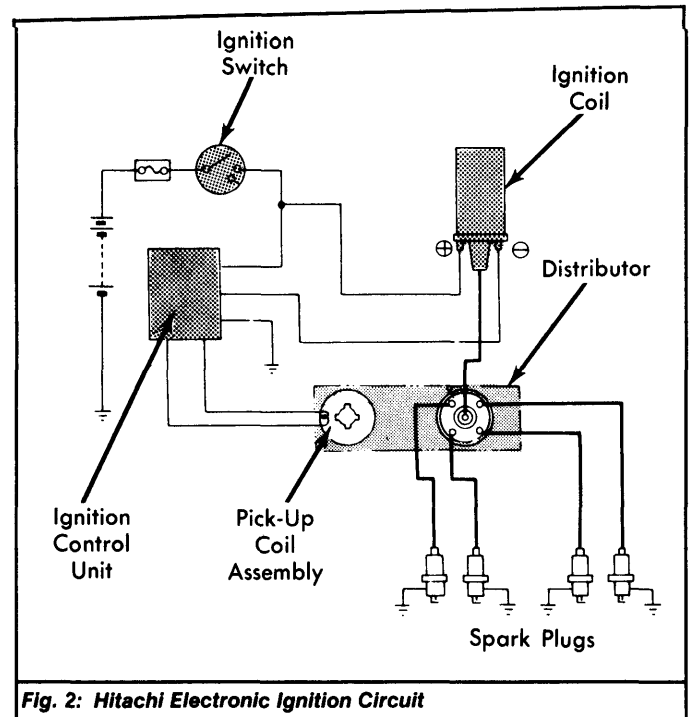

Fig. 2: Hitachi Electronic Ignition Circuit

SPECIFICATIONS

CENTRIFUGAL & VACUUM ADVANCE

See appropriate DISTRIBUTOR ADVANCE SPECIFICATIONS table in this section.

ADJUSTMENTS

PICK-UP COIL AIR GAP

Align tooth of reluctor with pole piece of pick-up coil. Loosen pick-up coil hold-down screw. Insert a .014" (.35 mm) feeler gauge between tooth and pole piece. Move pick-up coil against gauge and tighten hold-down screw. Air gap should be .012-.016" (.3-.4 mm). See Fig. 3.

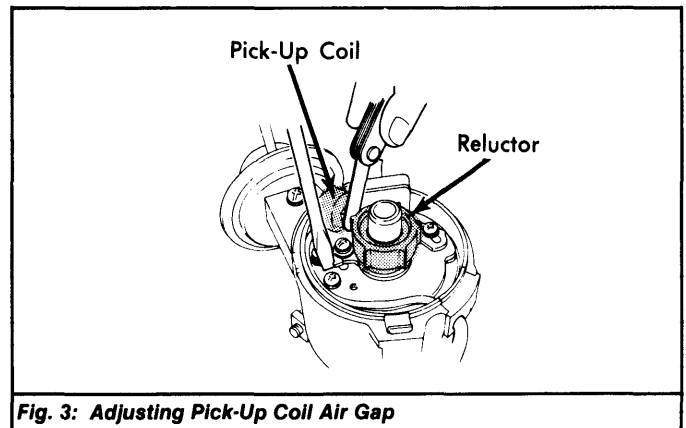

Fig. 3: Adjusting Pick-Up Coil Air Gap

4-44 1974-79 DISTRIBUTORS & IGNITION SYSTEMS Hitachi Electronic Ignition (Cont.)

TESTING

IGNITION SYSTEM

- 1) Turn ignition on. Connect negative lead of voltmeter to ground and positive lead to negative terminal of ignition coil. Voltage should be within 1 volt of battery voltage. If not, proceed to step 8).
- 2) If reading in step 1) was within 1 volt of battery voltage, turn ignition off and disconnect 2-pole connector. See Fig. 4.

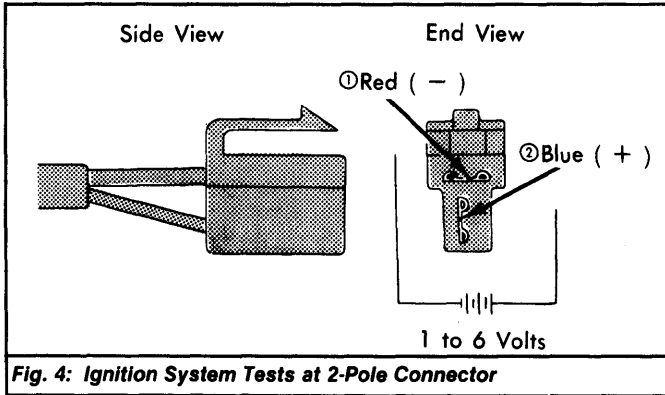

Fig. 4: Ignition System Tests at 2-Pole Connector

- 3) Using an ohmmeter set to the x100 scale, measure resistance between terminals in distributor side of 2-pole connector. Reading should be 600-850 ohms. If not, replace pick-up coil.
- 4) If reading was within specifications, turn ignition off. Using an ohmmeter set to the x1 scale, measure resistance between ground and ignition control unit side. Resistance should be less than .5 ohm. If not, check ground wire at regulator mounting screw.
- 5) If resistance is less than .5 ohm, turn ignition off and check air gap between reluctor and pick-up coil. Adjust as necessary.
- 6) If air gap was originally within specifications, turn ignition off and disconnect 2-pole connector. Disconnect secondary wire from distributor and hold wire 1/4" from engine ground. Turn ignition on and check whether spark jumps when a small voltage (1-6 volts) is intermittently applied to terminals 1 and 2 on ignition control unit side of connector.

NOTE: Do not use battery voltage for this test or damage may occur to ignition control unit.

- 7) If spark occurs, there is no trouble with electronic ignition system. If no spark occurs, replace ignition control unit.
- 8) If reading in step 1) was not within 1.0 volt of battery voltage, turn ignition on and check voltage at positive terminal of ignition coil. If not equal to battery voltage, check wiring between ignition switch and positive terminal of ignition coil. Repair or replace as necessary. If okay, check connector, switch, fuse and wiring back to the battery.
- 9) If reading at coil positive terminal was within 1.0 volt of battery voltage, disconnect lead at negative terminal (coming from ignition control unit) and turn ignition on. Voltage at negative terminal should be within 1.0 volt of battery voltage.

- 10) If it is, but engine will not start, replace ignition control unit. If not within 1.0 volt, remove tachometer lead (if equipped) at ignition coil. Turn ignition on and again check voltage at negative terminal of coil. If reading is correct, but engine will not start, check wiring harnesses from negative terminal of coil to tachometer for short circuit. If still not within 1.0 volt, replace ignition control unit.

OVERHAUL

DISASSEMBLY

Remove distributor cap and rotor. Remove pick-up coil, vacuum controller, and pinion. Remove pick-up coil base and shaft and governor assembly from housing. Remove shaft, governor assembly, and weights.

REASSEMBLY

- 1) Reassemble distributor in reverse order of disassembly. Install weight spring with longest, free length to shorter hole side of timing lever. When installing rotor assembly, match notch in pick-up coil base with groove end of housing.
- 2) When installing vacuum controller, tighten only the screw holding the controller to the housing. Tighten screw between lever and pick-up coil base when installing pick-up coil.
- 3) When installing pick-up coil, adjust air gap to specifications. Position rotor shaft so flat side is centered on pole piece of pick-up coil. See Fig. 5.
- 4) Align match mark "A" on pinion gear with right side of notch "B" on lower end of housing. See Fig. 5. After assembly, check centrifugal advance by using a distributor tester.

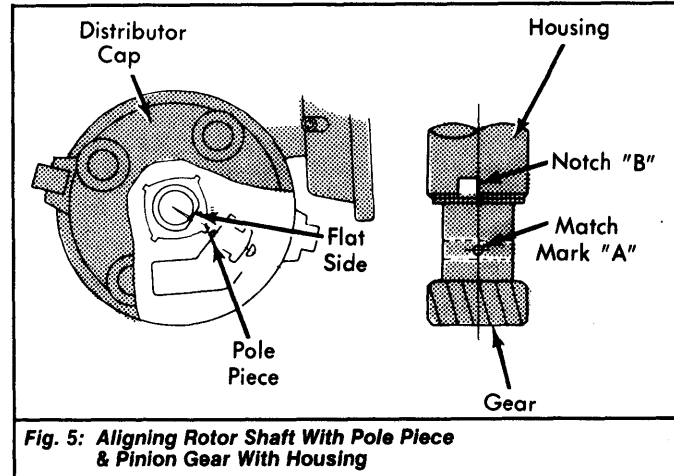

Fig. 5: Aligning Rotor Shaft With Pole Piece & Pinion Gear With Housing