

1974-79 EXHAUST EMISSION SYSTEMS

Toyota Crankcase Ventilation

3-423

All Models

DESCRIPTION

The closed crankcase ventilation system consists of a hose connecting the air cleaner and crankcase and a hose connecting the crankcase and intake manifold with a ventilation valve located in it. Hose connections vary with engine.

Air enters system from air cleaner to cylinder head cover. Fresh air mixes with crankcase fumes and enters ventilation tube into ventilation valve. Ventilation valve regulates amount of air flow to meet the change in operating conditions. The air is then drawn into the intake manifold, through a connecting hose, where it enters the combustion system and is burned.

OPERATION

The PCV valve is operated by pressure difference between crankcase and intake manifold. When there is no pressure difference (engine not running) or when pressure of intake manifold is greater than that of crankcase, valve is closed.

During engine idle, high manifold vacuum overcomes the valve spring and valve is pulled toward intake manifold side by vacuum. This causes air to pass through the restricted passage between valve and housing. During normal engine operation, valve remains in a position where spring pressure and intake manifold vacuum balance. Amount of air flow then depends on position of valve.

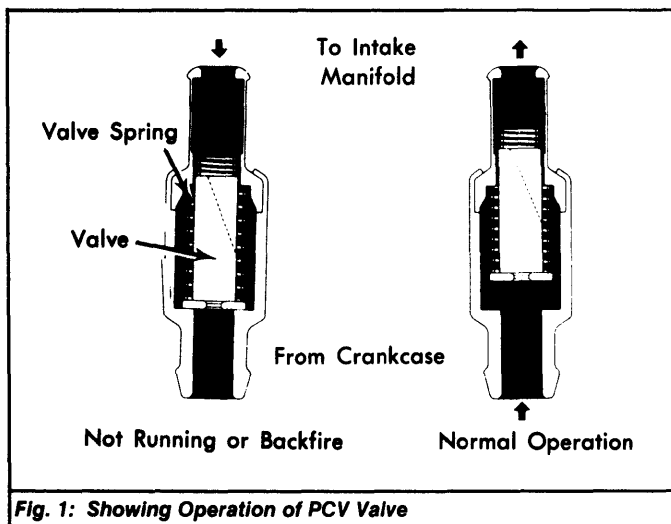

TESTING

Remove PCV valve and attach a clean piece of hose to cylinder head end of valve. Blow air through valve. Air should pass through. Move clean hose to intake manifold end of valve and again blow air through valve. Air should NOT pass through. Replace valve if defective.

MAINTENANCE

Every 15,000 miles, clean air filter element, PCV valve, and oil filler cap. Every 30,000 miles, replace air filter element and PCV valve.

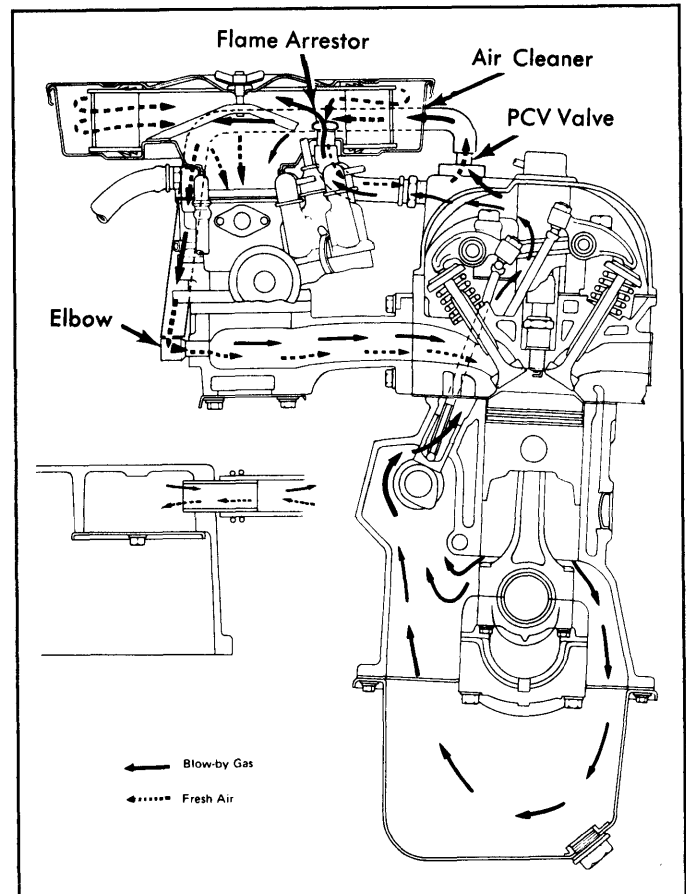

Fig. 2: 2T-C Engine Crankcase Ventilation System

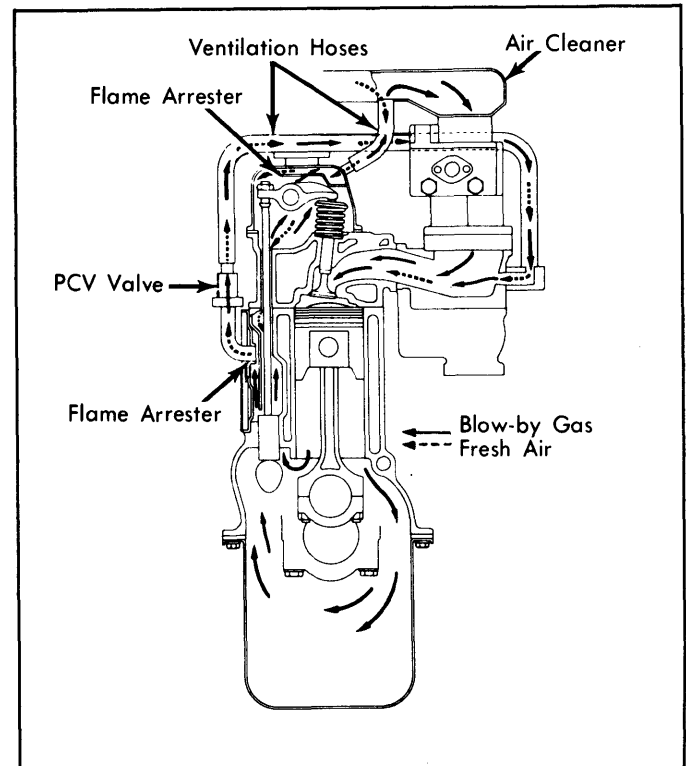

Fig. 3: 2F Engine Crankcase Ventilation System

1974-79 EXHAUST EMISSION SYSTEMS Toyota Crankcase Ventilation (Cont.)

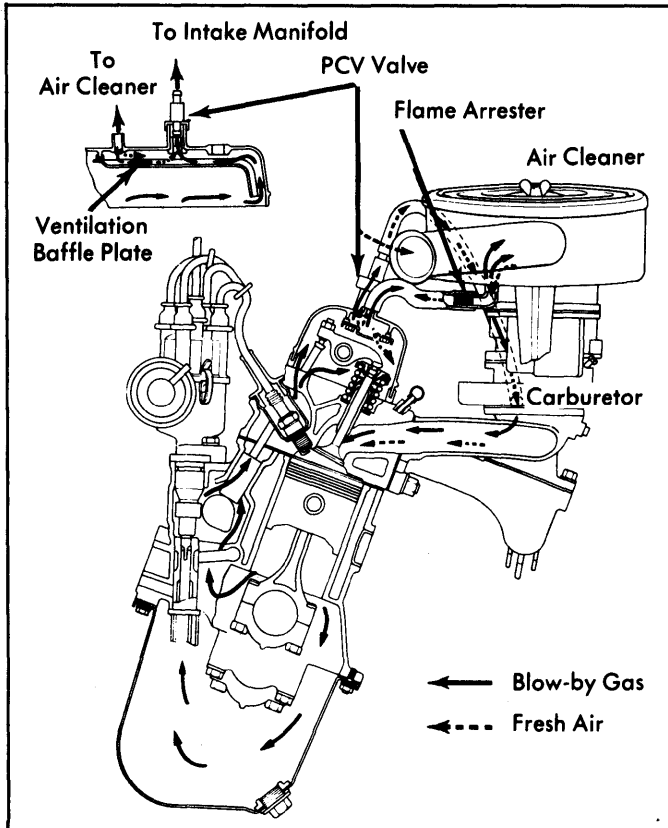

Fig. 4: 3K-C Engine Crankcase Ventilation System

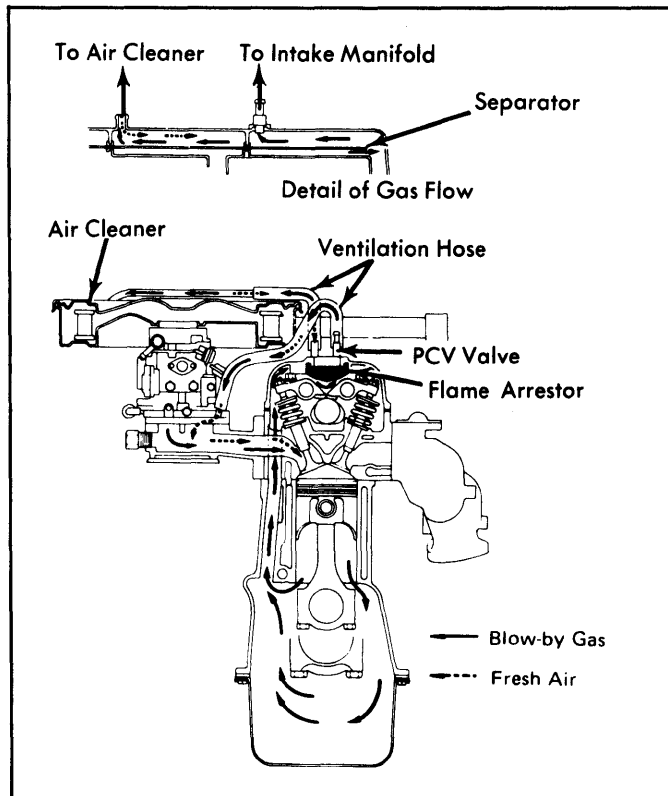

Fig. 5: 20R Engine Crankcase Ventilation System

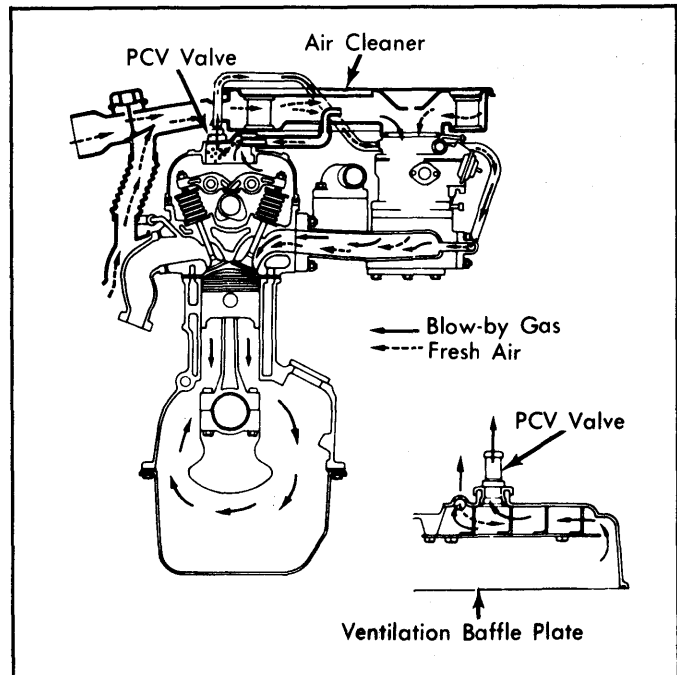

Fig. 6: 4M Engine Crankcase Ventilation System

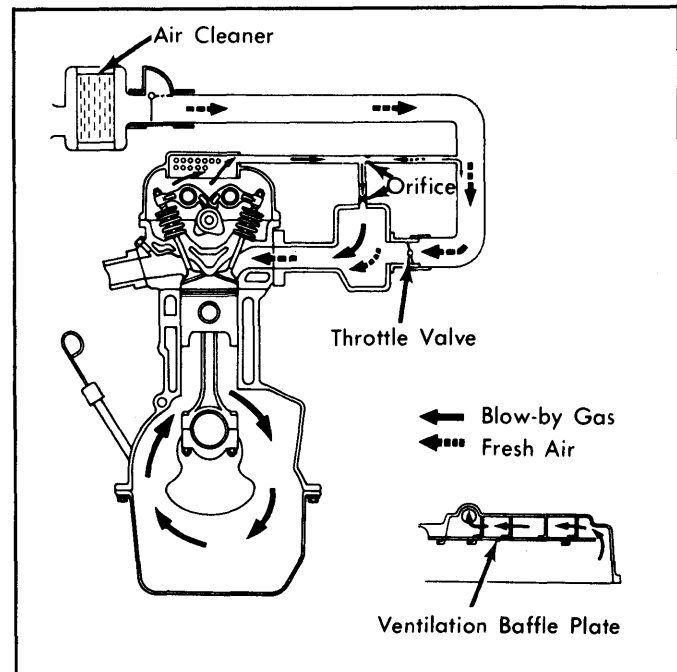

Fig. 7: 4ME Engine Crankcase Ventilation System