

1974-79 EXHAUST EMISSION SYSTEMS

Subaru Vacuum Diagrams

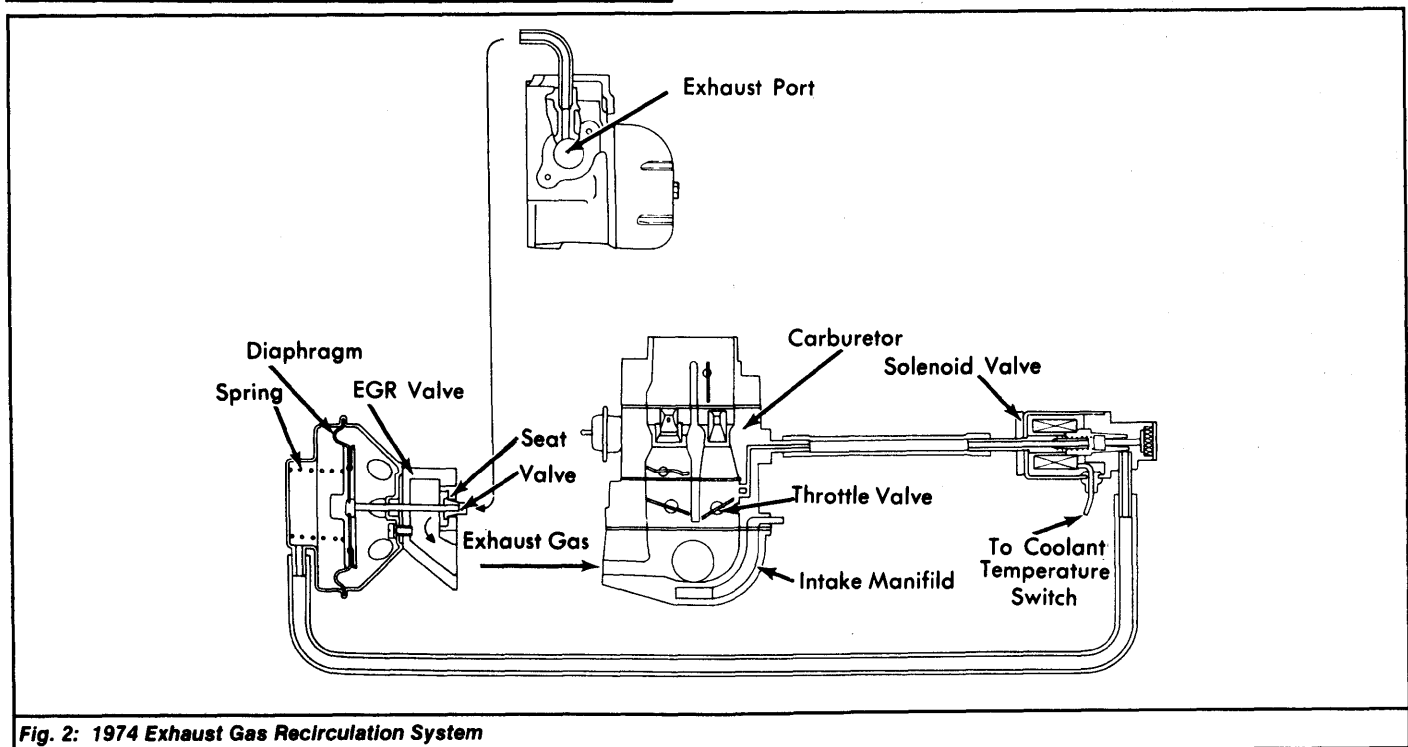
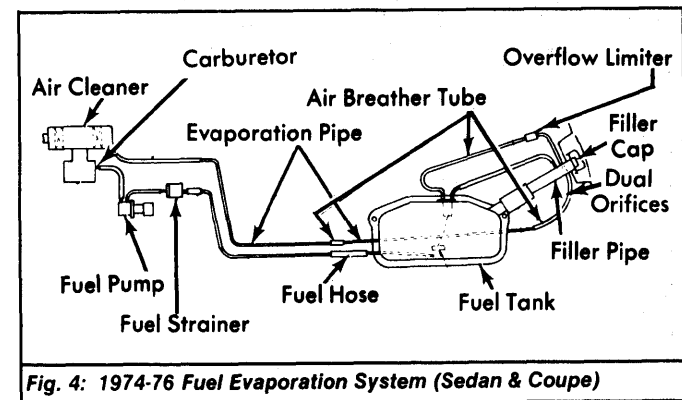
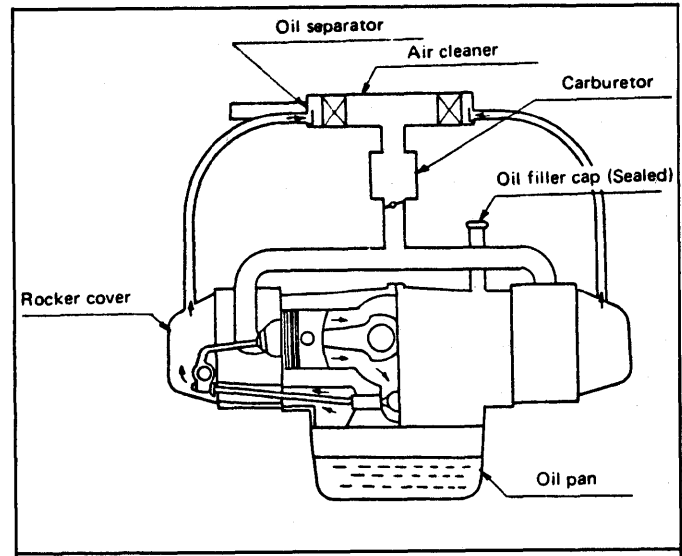
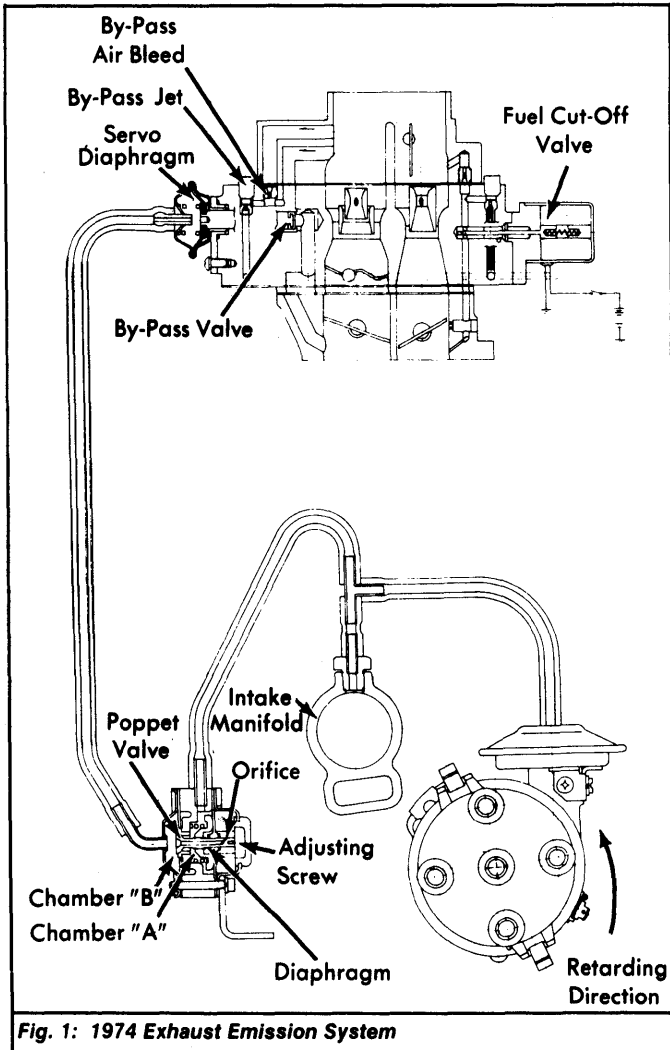

1974-79 EXHAUST EMISSION SYSTEMS

Subaru Vacuum Diagrams (Cont.)

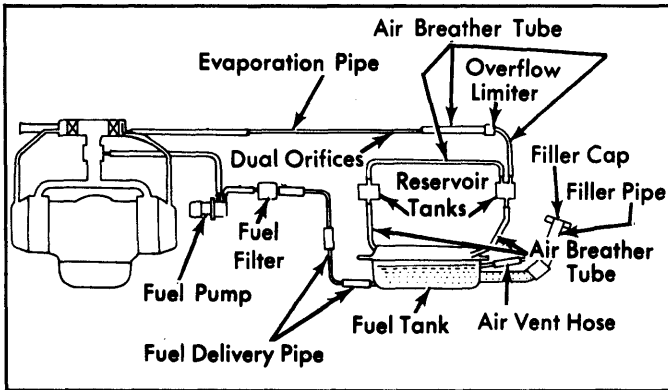

Fig. 5: 1974-76 Fuel Evaporation System (Station Wagon)

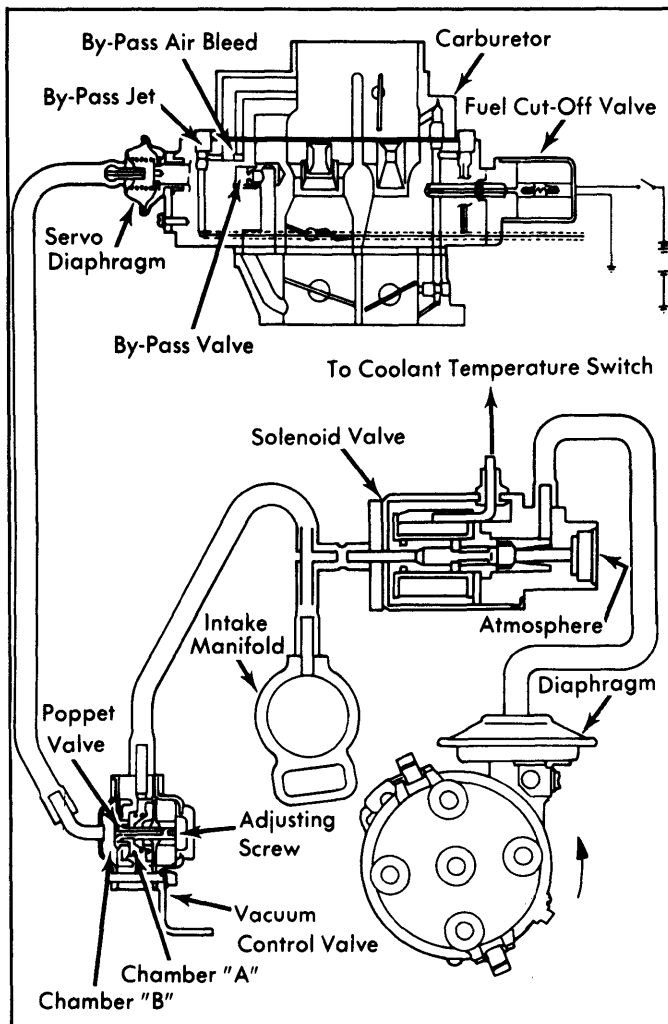

Fig. 6: 1975 Exhaust Emission System (Federal Auto. Trans. & California Man. Trans.)

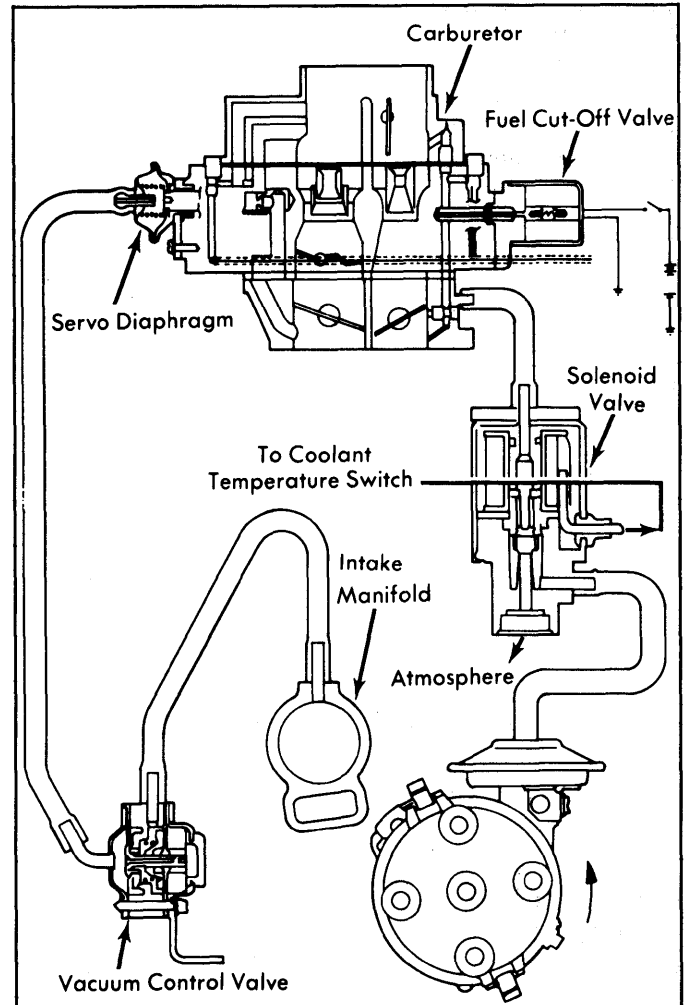

Fig. 7: 1975 Exhaust Emission System (Federal Man. Trans.)

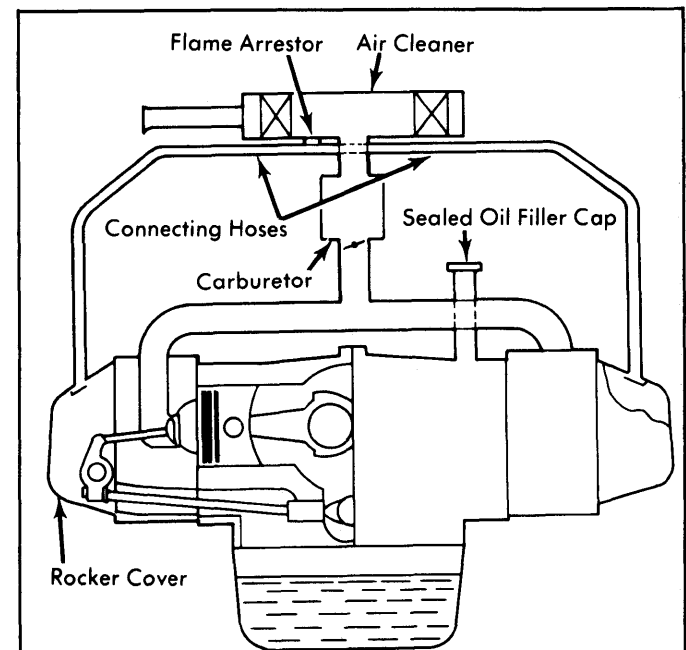
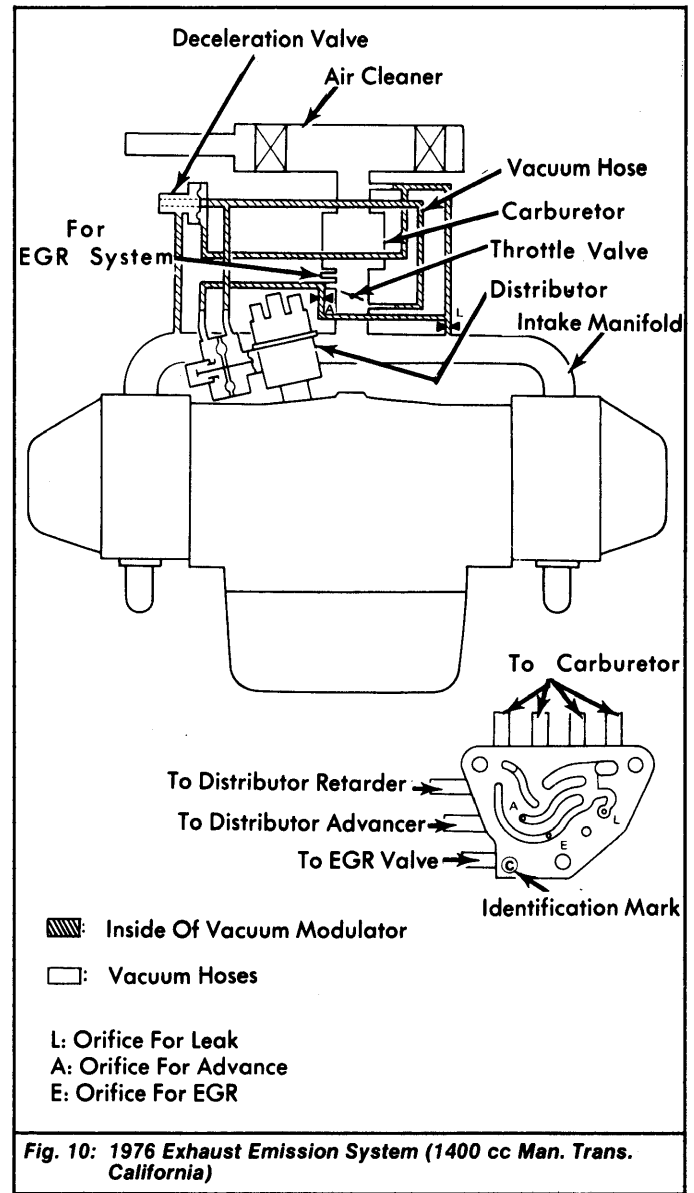
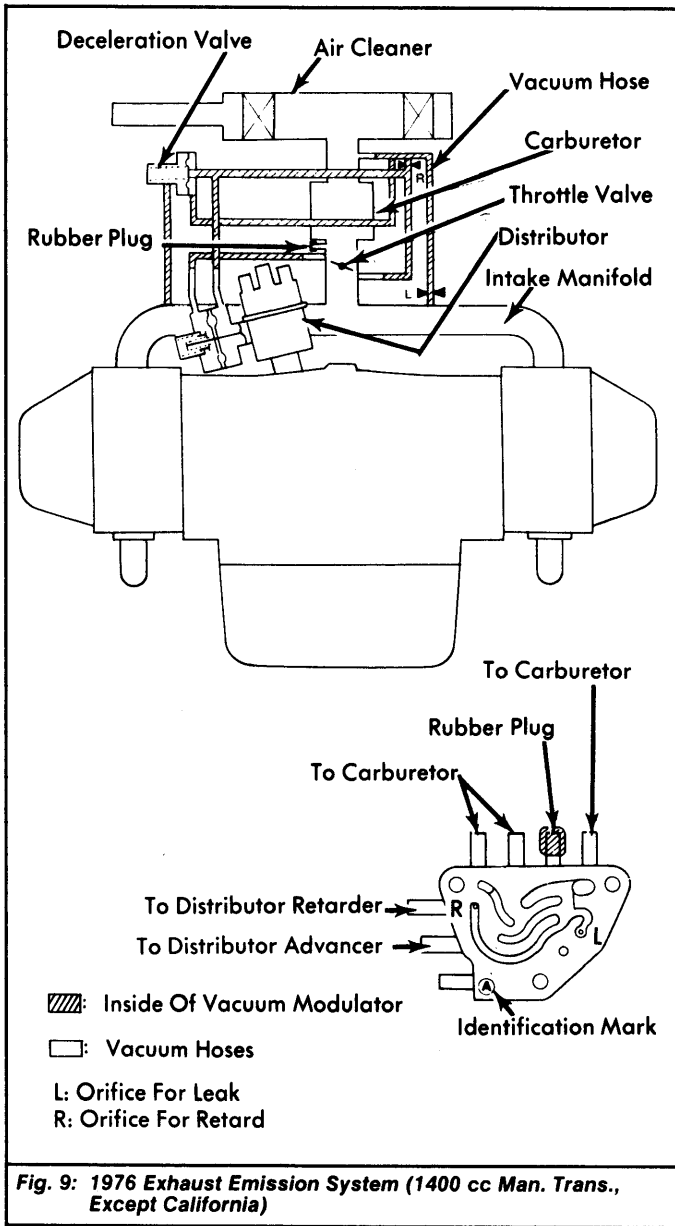

Fig. 8: 1975-78 Positive Crankcase Ventilation System

1974-79 EXHAUST EMISSION SYSTEMS Subaru Vacuum Diagrams (Cont.)



1974-79 EXHAUST EMISSION SYSTEMS

Subaru Vacuum Diagrams (Cont.)

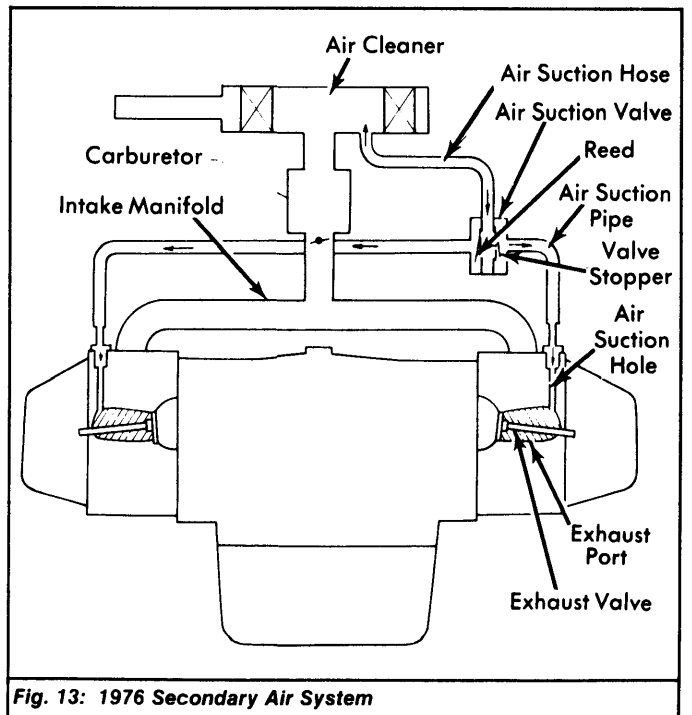
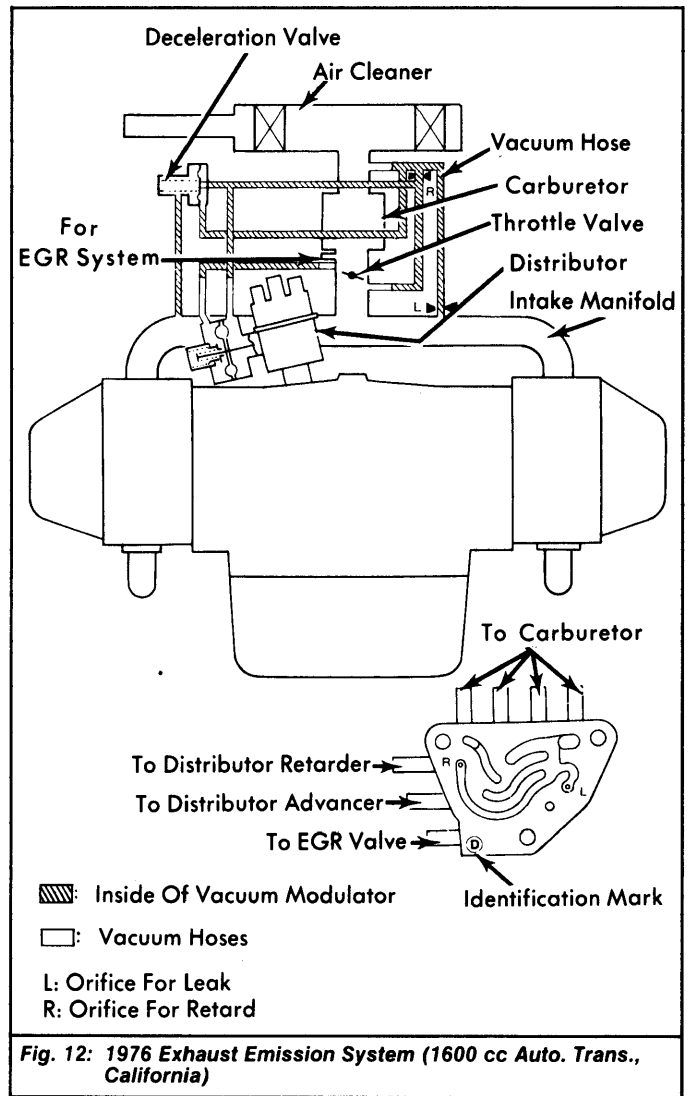
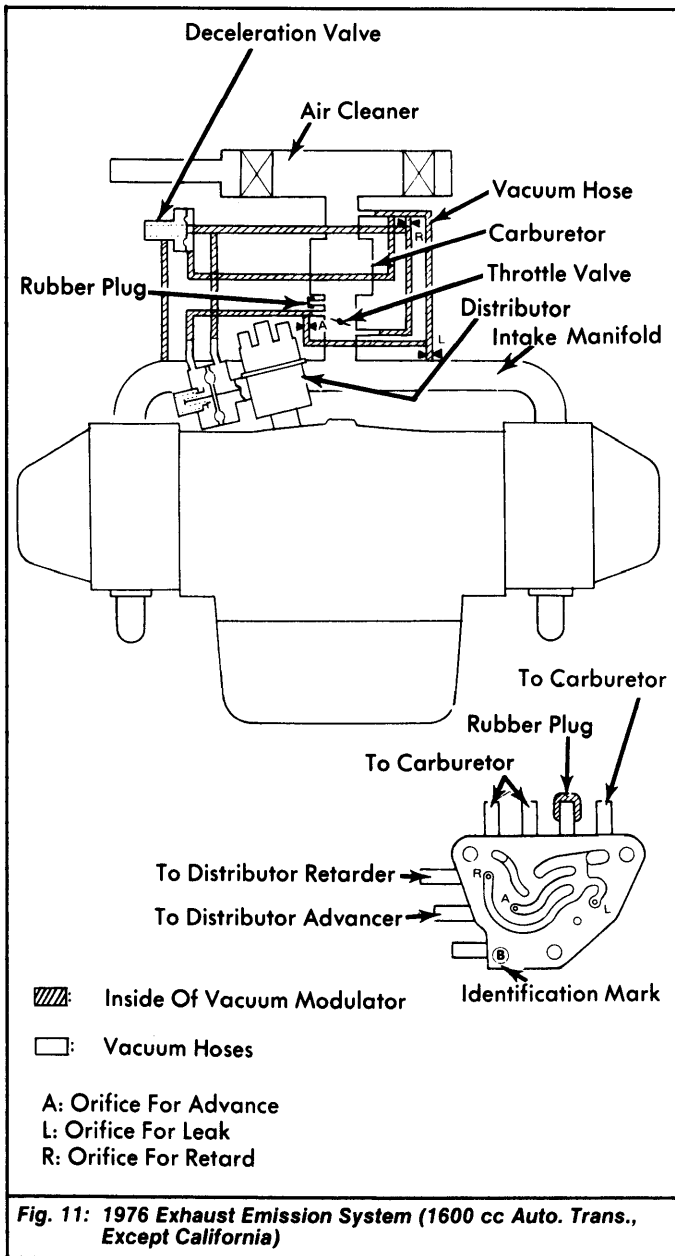

1974-79 EXHAUST EMISSION SYSTEMS Subaru Vacuum Diagrams (Cont.)

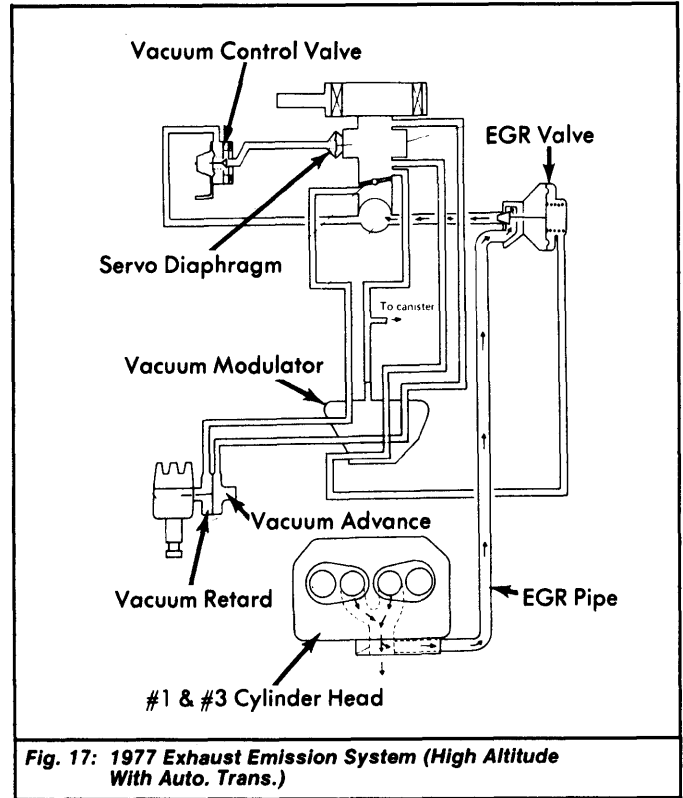
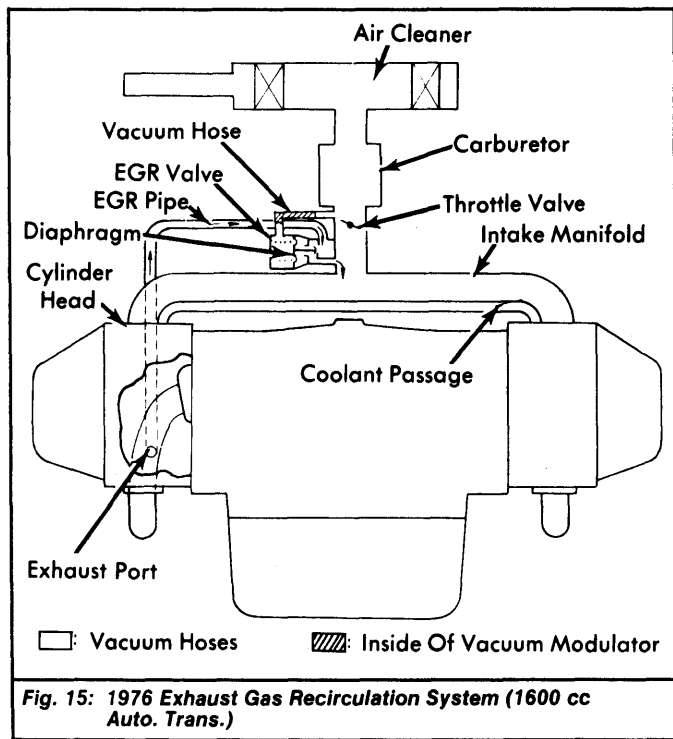
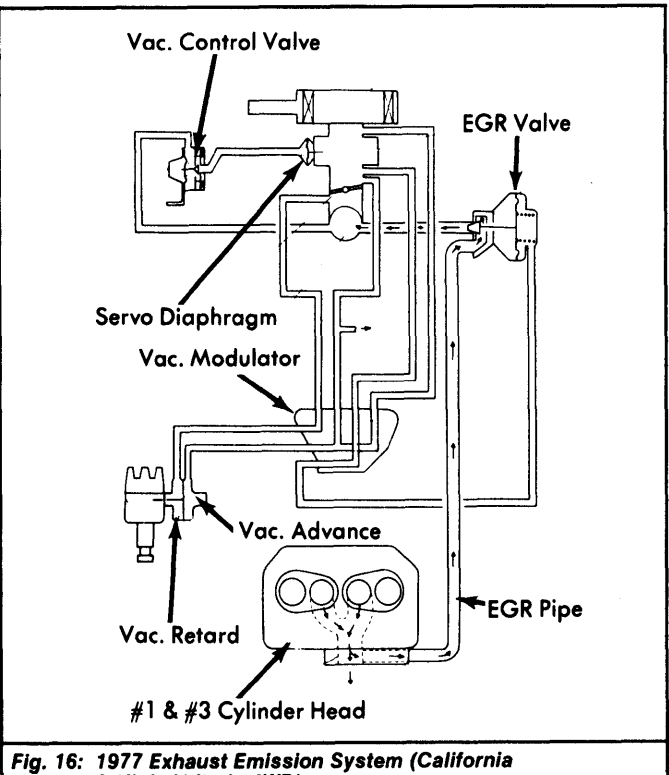
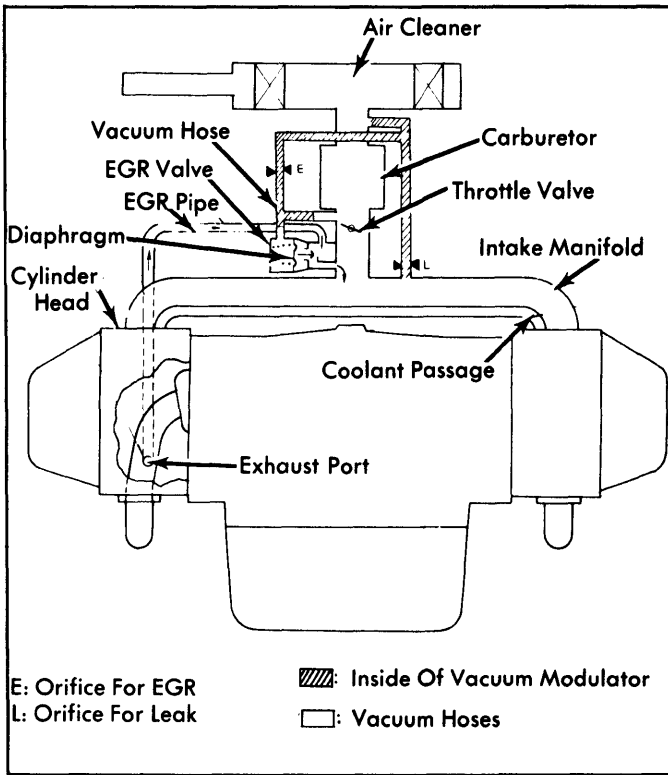

1974-79 EXHAUST EMISSION SYSTEMS Subaru Vacuum Diagrams (Cont.)

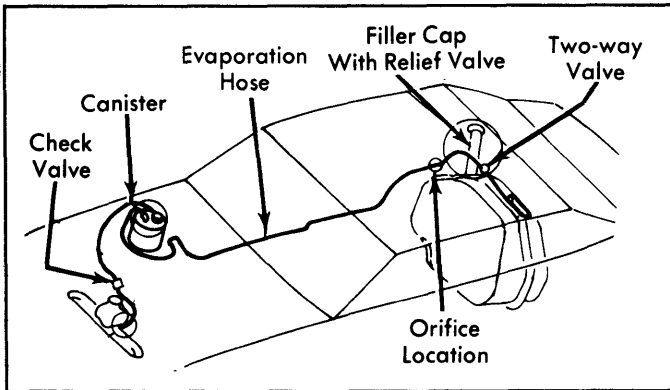

Fig. 18: 1977-78 Fuel Evaporation System (Sedan, Coupe & Hardtop)

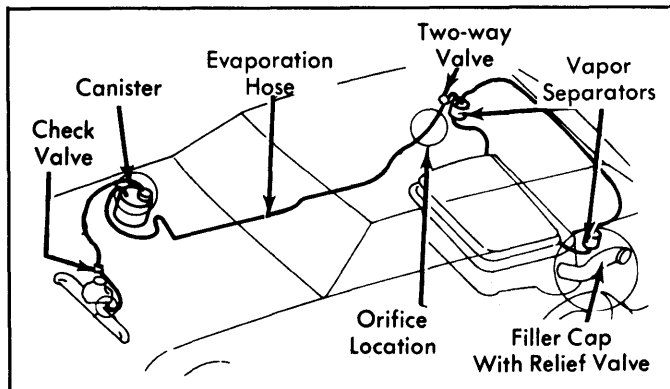

Fig. 19: 1977-78 Fuel Evaporation System (Station Wagon & 4WD)

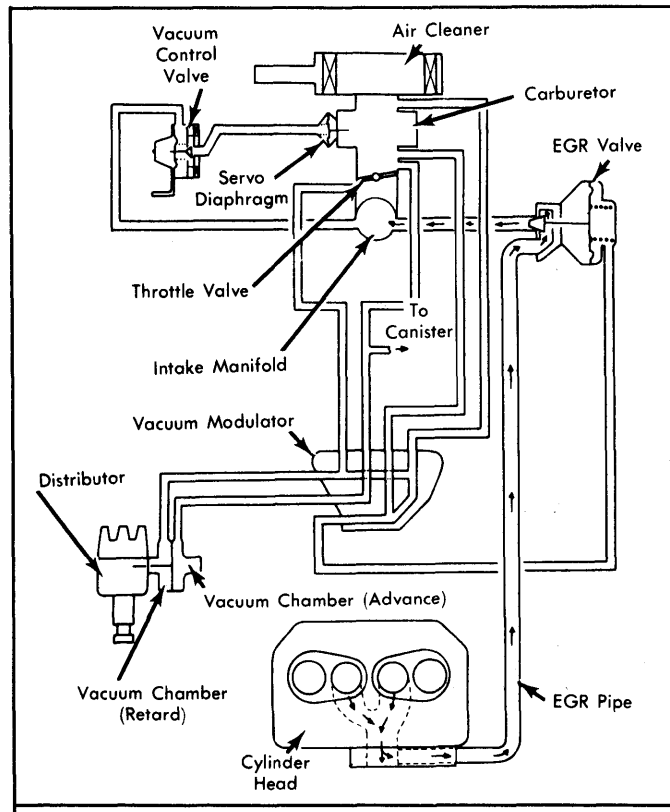

Fig. 20: 1977-79 Exhaust Emission System (Federal With Man. Trans., Except 4WD)

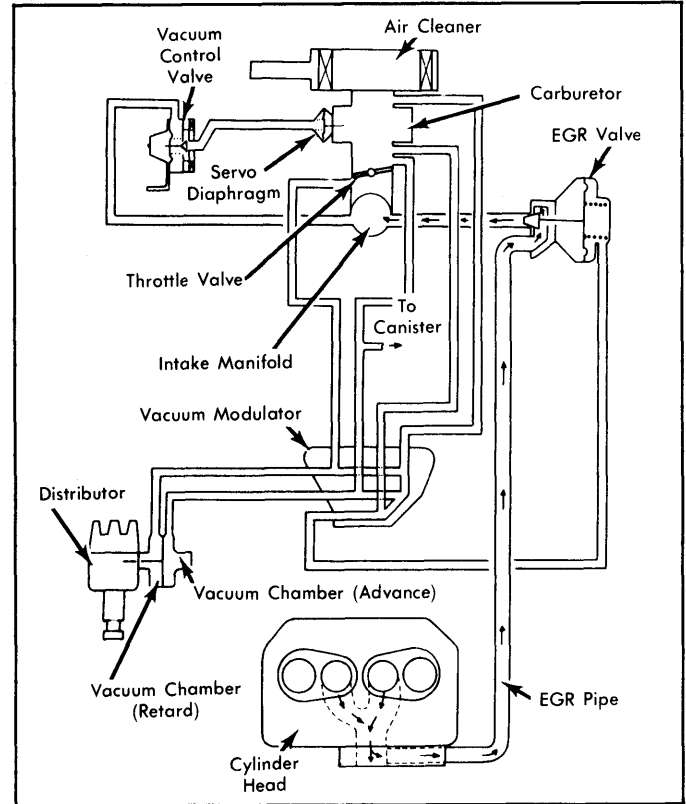

Fig. 21: 1977-79 Exhaust Emission System (Federal 4WD)

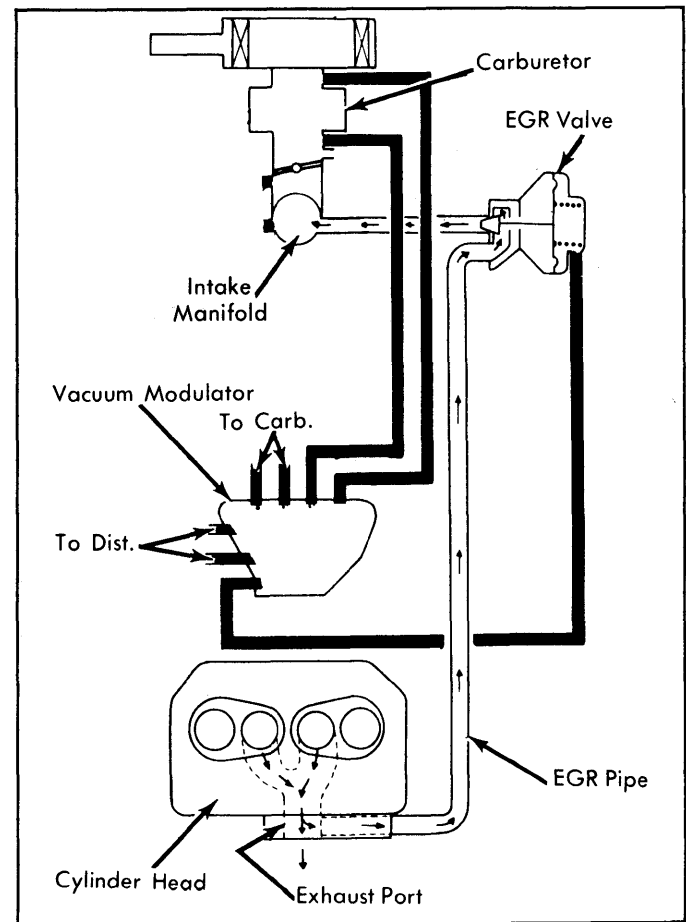

Fig. 22: 1978 Exhaust Gas Recirculation System

1974-79 EXHAUST EMISSION SYSTEMS Subaru Vacuum Diagrams (Cont.)

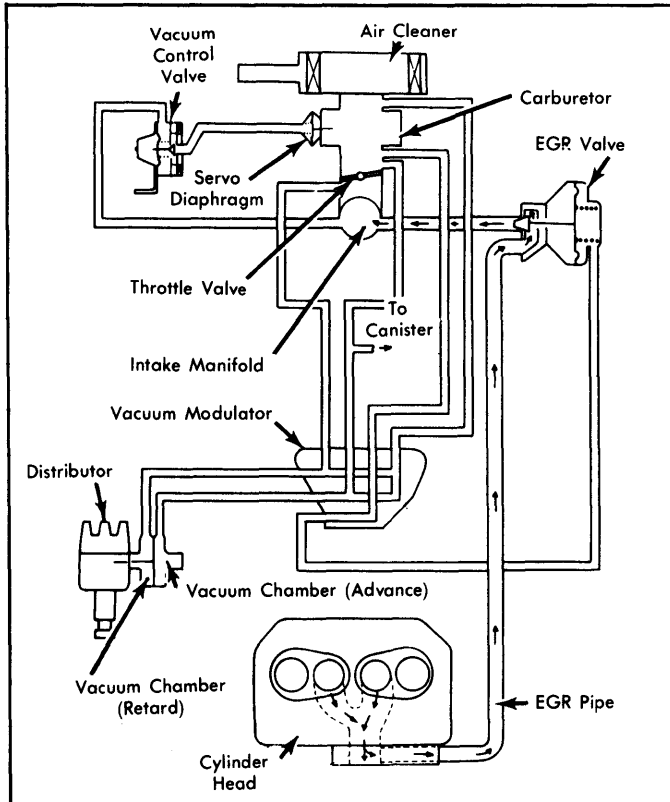

Fig. 23: 1979 Exhaust Emission System (Federal With Auto. Trans., Except 4WD)

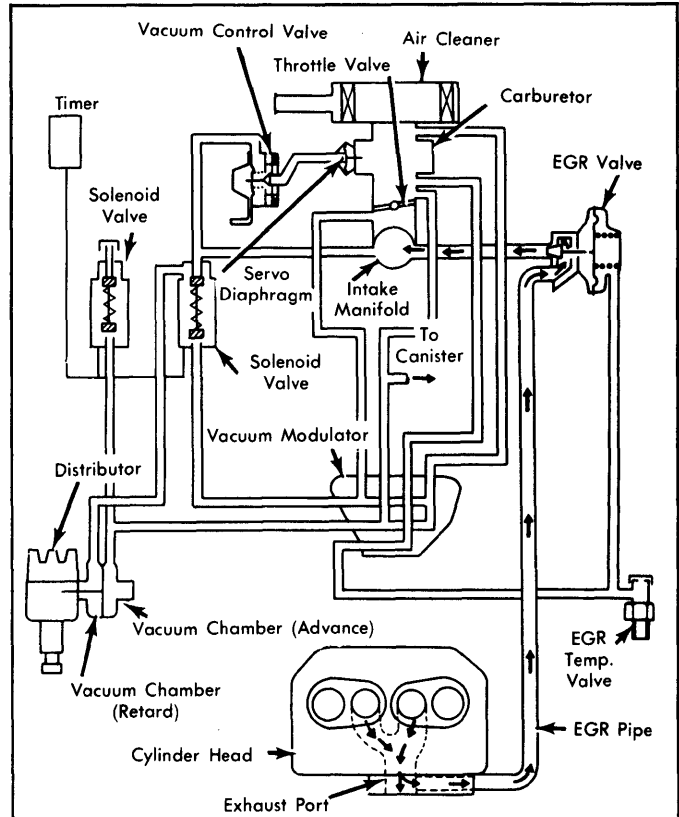

Fig. 25: 1979 Exhaust Emission System (California With Auto. Trans., Except 4WD)

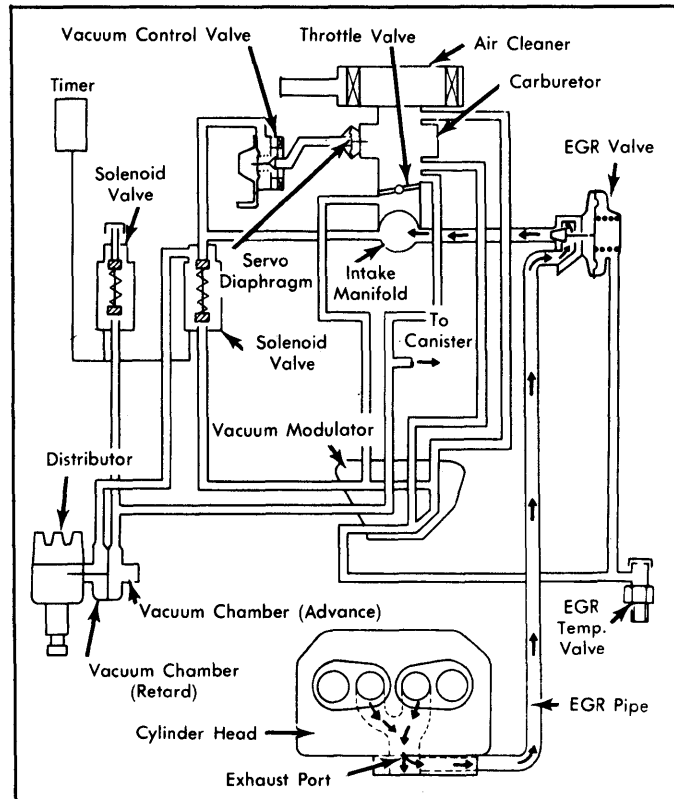

Fig. 24: 1979 Exhaust Emission System (California With Man. Trans., Except 4WD)

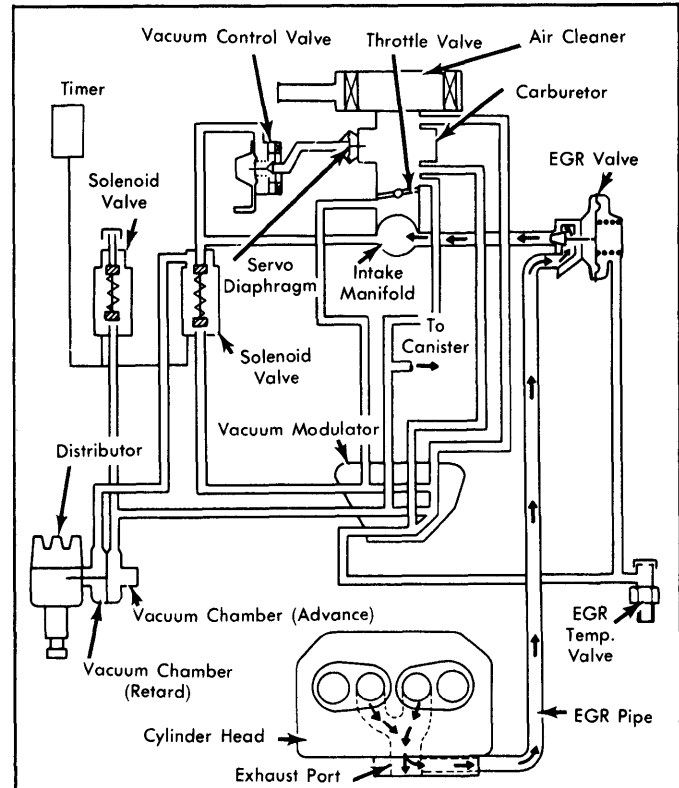

Fig. 26: 1979 Exhaust Emission System (California 4WD)