

1974-79 EXHAUST EMISSION SYSTEMS

Jensen-Healey EGR System

3-259

1974 Interceptor

DESCRIPTION

Exhaust Gas Recirculation (EGR) system allows a predetermined amount of hot exhaust gas to recirculate and dilute incoming air/fuel mixture. This diluting of air/fuel mixture reduces peak flame temperature during combustion, thereby reducing oxides of nitrogen (NOx).

OPERATION

VENTURI VACUUM CONTROL SYSTEM

The venturi vacuum controlled, poppet type EGR valve is used to modulate exhaust gas flow from exhaust gas crossover pipe into incoming air/fuel mixture.

A vacuum tap at throat of carburetor venturi is used to provide control vacuum. Because of the low amount of vacuum, it is necessary to use a vacuum amplifier to increase vacuum to a level required to operate EGR valve. Elimination of exhaust gas recirculation at wide open throttle is accomplished by a dump diaphragm which compares venturi and manifold vacuum to determine when wide open throttle is reached.

At wide open throttle, internal reservoir vacuum is dumped, limiting output to EGR valve opening point. Opening point is set above manifold vacuum available at wide open throttle, permitting EGR valve to be closed at wide open throttle.

COOLANT CONTROL EGR VALVE

The Coolant Control EGR (CCEGR) valve is mounted in top tank of radiator. When engine coolant temperature reaches 65°F (18°C), valve opens so that vacuum is applied to open EGR control valve allowing exhaust gas to recirculate. On some models, a 90°F (32°C) CCEGR valve is mounted in thermostatic housing.

EGR DELAY TIMER

Some models are equipped with EGR delay system having an electrical timer mounted on engine compartment firewall which controls an engine mounted solenoid. See Fig. 1. Solenoid is connected by vacuum hoses between carburetor venturi signal and vacuum amplifier. The purpose of this system is to prevent exhaust gas recirculation for approximately 35 seconds after ignition is turned on.

TROUBLE SHOOTING

EGR VALVE STEM DOES NOT MOVE ON SYSTEM TEST

- 1) Check for correct hose connections and leak check to confirm all hoses are in good condition. Check EGR valve by connecting external vacuum source of at least 20 in. Hg to valve diaphragm.
- 2) If no valve movement occurs, replace valve. If valve opens 1/8", pinch off supply hose to check for diaphragm leakage. Valve should remain open 30 seconds or longer. If leakage occurs, replace valve.

EGR VALVE OPERATES WITH EXTERNAL VACUUM, NOT ON SYSTEM TEST

- 1) With engine at normal operating temperature, check EGR valve by disconnecting and plugging vacuum hose. If normal operation is restored, replace temperature control valve.
- 2) On ported vacuum controlled system, remove carburetor and inspect port (slot type) in throttle bore and associated vacuum passages including limiting orifice at hose end of passages. Clean carburetor with solvent and clear air passages with light air pressure.
- 3) On venturi vacuum controlled system, remove venturi vacuum hose from carburetor nipple. With engine at idle, apply 2 in. Hg vacuum to hose (on models having EGR delay system, remove Orange stripe hose from delay solenoid). Engine speed should drop 150 RPM or

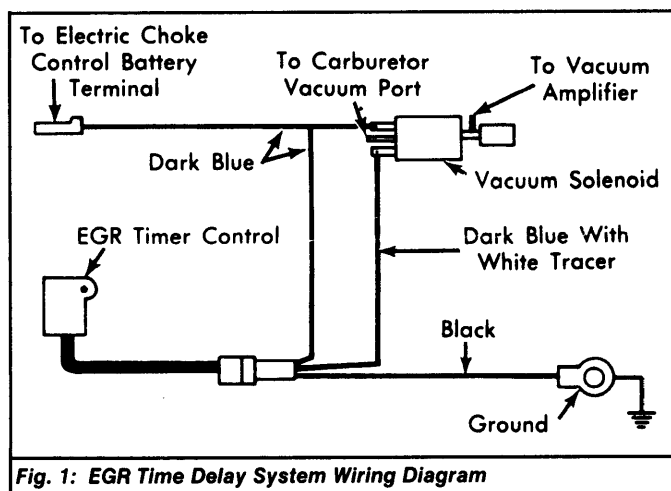

Fig. 1: EGR Time Delay System Wiring Diagram

more and EGR valve stem should move 1/8" or more. If this does not occur, replace vacuum control valve.

- 4) If vacuum control amplifier operates normally, a plugged vacuum tap to carburetor is indicated. Clean carburetor with solvent and clear air passages with light air pressure.

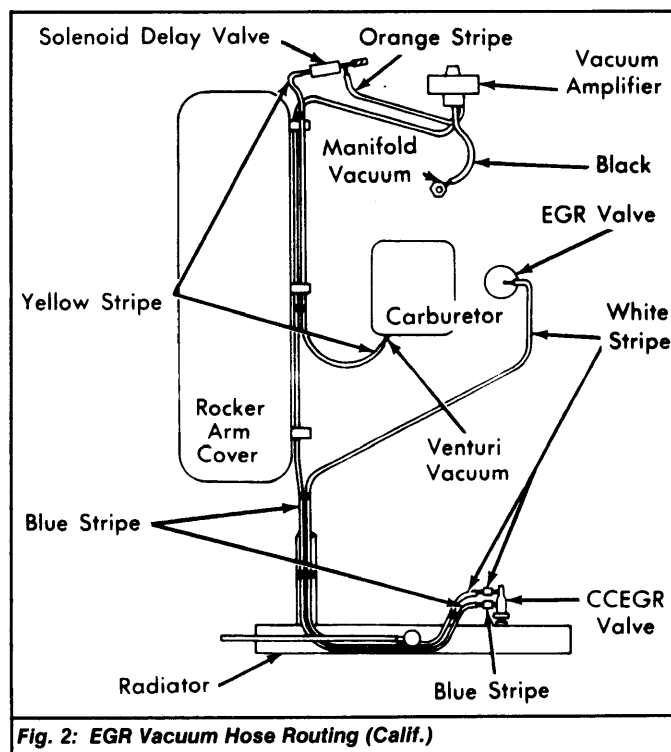

Fig. 2: EGR Vacuum Hose Routing (Calif.)

ENGINE WON'T IDLE, DIES ON RETURN TO IDLE, ROUGH OR SLOW IDLE

Disconnect hose from EGR valve and plug hose, recheck idle. If satisfactory, replace vacuum control amplifier. If vacuum hose removal does not correct problem, remove EGR valve and inspect to ensure poppet is seated. Clean poppet seat. Replace if poppet does not seat correctly.

POOR COLD ENGINE DRIVEABILITY

Disconnect hose from coolant control EGR valve and allow to vent. Road test vehicle. If performance is improved, replace coolant control EGR valve.

1974-79 EXHAUST EMISSION SYSTEMS

Jensen-Healey EGR System (Cont.)

POOR PERFORMANCE AT WIDE OPEN THROTTLE

Disconnect hose from EGR valve and plug hose. Road test vehicle. If performance is restored, replace vacuum control amplifier.

TESTING

- 1) Every 12,000 miles or 12 months, complete EGR system should be inspected and tested. Check all hose for damage or air leaks. All moving parts must be free from plugging or sticking as a result of deposits.
- 2) With air temperature at least 68°F (20°C), allow to engine to idle in Neutral. With carburetor throttle closed, abruptly accelerate engine to approximately 2000-3000 RPM.
- 3) Visible movement of EGR valve stem should occur. To determine movement of EGR valve, observe groove on valve stem. Repeat test several times to assure system is operating properly.
- 4) Check valve and passages for exhaust gas flow by applying a vacuum of at least 10 in. Hg directly to EGR valve. Idle speed should drop 150 RPM or more. If no change occurs, check for exhaust deposits in EGR valve or intake manifold. Remove EGR valve and clean deposits.

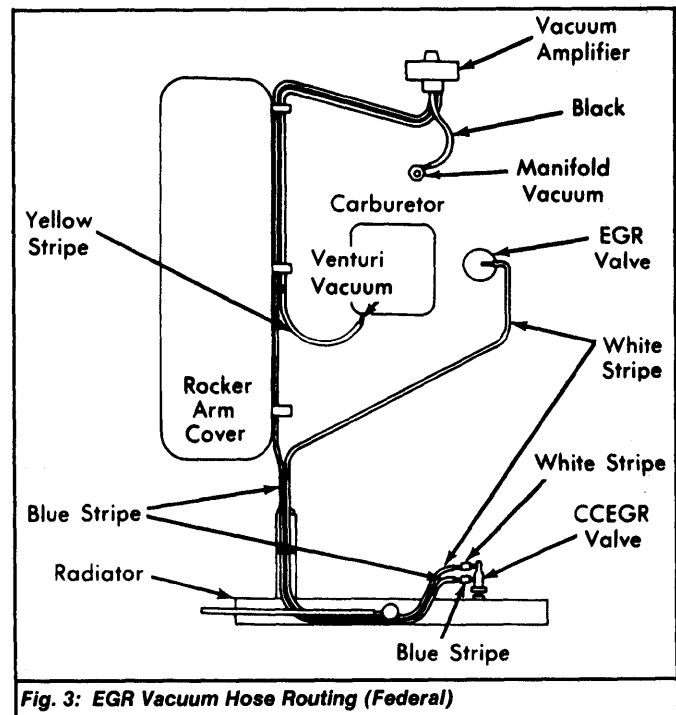

Fig. 3: EGR Vacuum Hose Routing (Federal)