

1974-79 EXHAUST EMISSION SYSTEMS

Jaguar Exhaust Gas Recirculation

3-249

All Models

DESCRIPTION

On 6-cylinder engine, the EGR system is used to reduce emission of oxides of nitrogen (NOx). The EGR valve is mounted on exhaust manifold and controls flow of exhaust gases into intake manifold. The control signal is taken from a throttle edge tapping, which gives no exhaust gas recirculation at idle speed or full load.

On V12 engine, the exhaust gas recirculation system is controlled by two solenoid-operated valves which are mounted near the outside center of each exhaust manifold. These valves meter a proportion of exhaust gas into the induction system during certain engine modes. The gas is diverted from the exhaust pipe downstream at a tapping ahead of the catalytic converters, and fed through valves and fixed orifices in the induction system.

is above 95°F (35°C). Also, above 60-65 MPH, there is no EGR. These functions are controlled by the EGR controller mounted inside the luggage compartment, behind the right-rear light cluster. See Fig. 2.

TESTING

EGR VALVE

6-Cylinder Engine - Apply external vacuum top EGR valve and ensure that diaphragm will hold vacuum until released. Valve should close when vacuum is released. Ensure that vacuum is available at EGR thermal vacuum switch. If coolant temperature is above 90°F (32°C), vacuum should be available to EGR valve.

V12 Engine - Attach hand-held vacuum pump to top side of valve and apply 6-10 in. Hg of vacuum. Valve should close and hold vacuum. Air should flow through valve when blown gently through valve from top. Valve should close and hold pressure when air is blown through bottom of valve. If not, replace EGR valve.

MAINTENANCE

EGR VALVE

6-Cylinder Engine - 1) Remove EGR valve from exhaust manifold. Clean base of valve with wire brush to remove deposits. Using a spark plug cleaner, clean valve seat and metering valve by holding diaphragm upward with fingers and blasting valve as 30 second intervals until clean.

2) Remove all traces of carbon and cleaning compound with compressed air. Examine ports in manifold and clean as necessary. Install EGR valve and check for proper operation.

V12 Engine - 1) Remove air cleaner covers. Disconnect battery. Disconnect spade connectors to right-side EGR valve. Mark position of connectors (top and bottom) for reassembly reference.

2) Disconnect EGR valve transfer pipe from down pipe take-off stub. Remove electrical connectors from rear of EGR valve. Remove and discard EGR valve to elbow gasket. Remove transfer pipe from EGR valve. To install, reverse removal procedure. At 50,000 mile service, both EGR valves must be replaced.

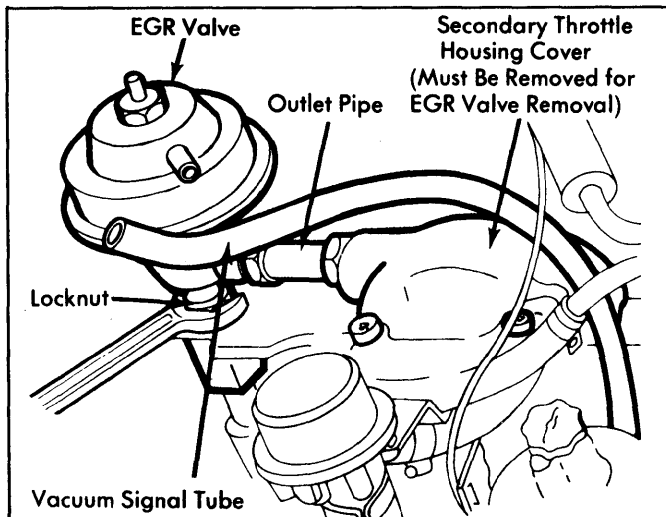

Fig. 1: 6-Cylinder Engine EGR Valve Location

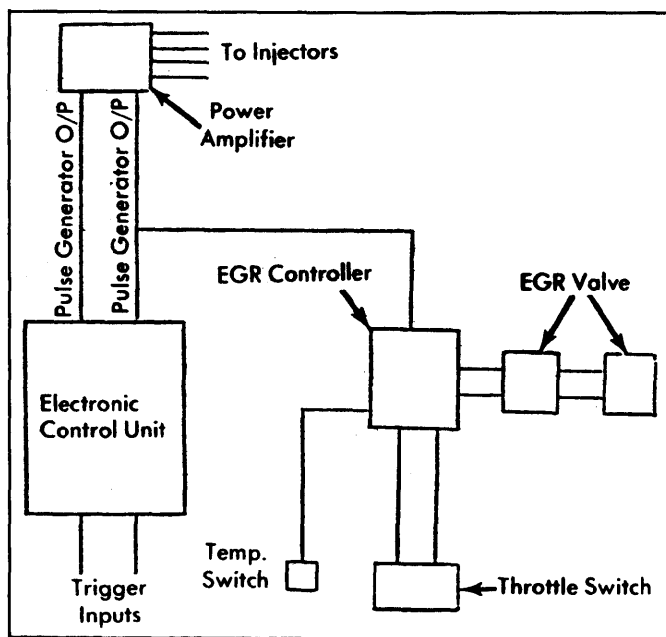

Fig. 2: V12 Engine EGR System Electrical Schematic

The signal that operates the EGR valves is determined by the position of the throttle switch. There is no recirculation at idle and full throttle. Recirculation is also restricted by a coolant temperature valve which does not allow exhaust gas flow through the EGR system until coolant

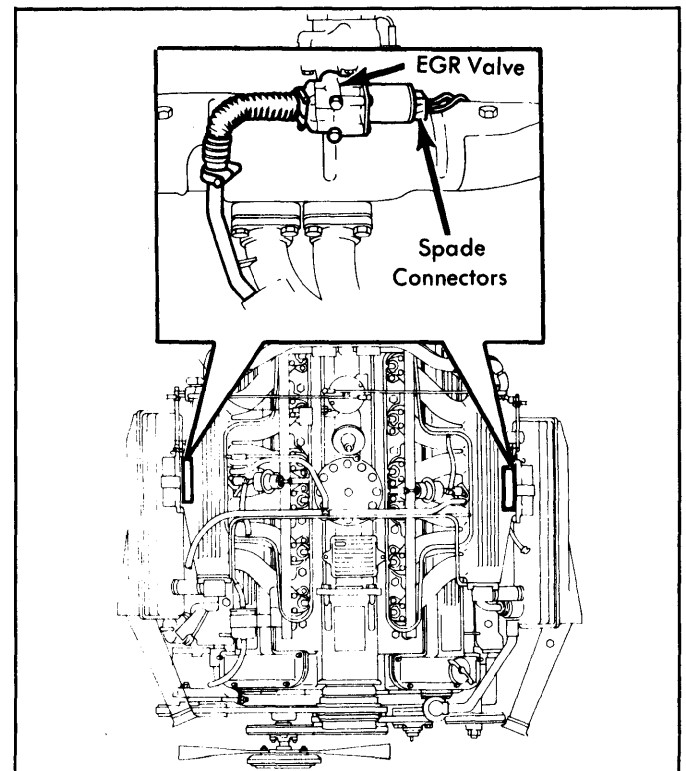

Fig. 3: V12 Engine EGR Valve Locations