

1974-79 EXHAUST EMISSION SYSTEMS

Honda Vacuum Diagrams

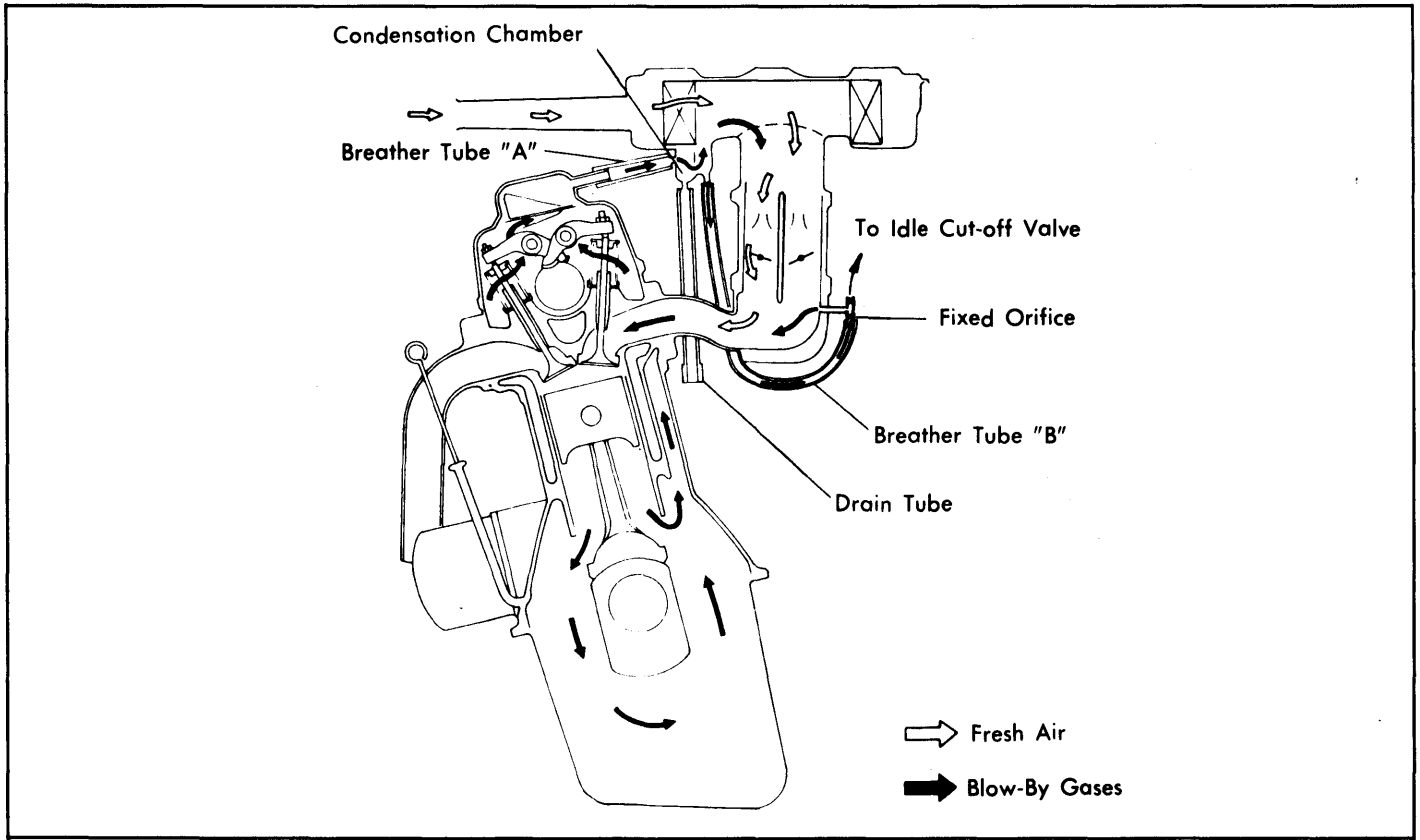

Fig. 1: 1974 Positive Crankcase Ventilation System (Typical)

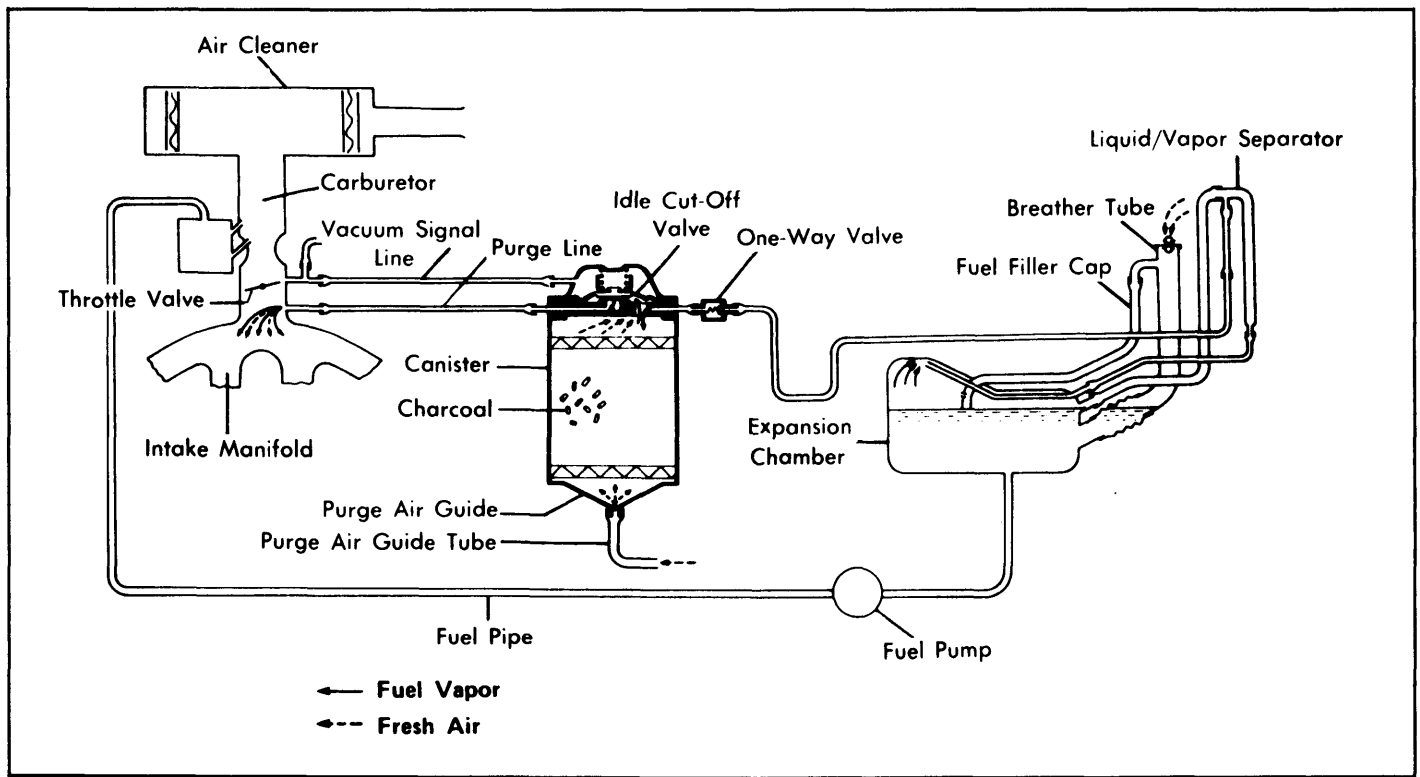

Fig. 2: 1974-76 Fuel Evaporation System

1974-79 EXHAUST EMISSION SYSTEMS

Honda Vacuum Diagrams (Cont.)

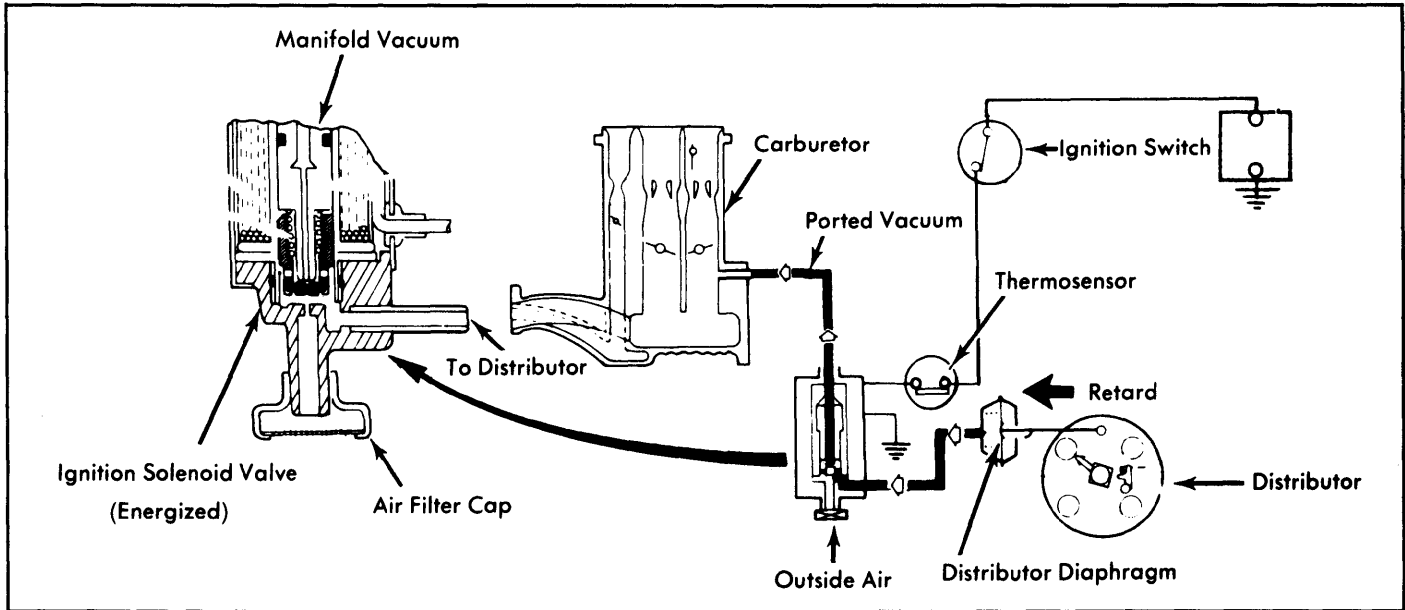

Fig. 3: 1975 Ignition Timing Control System (Auto. Trans.)

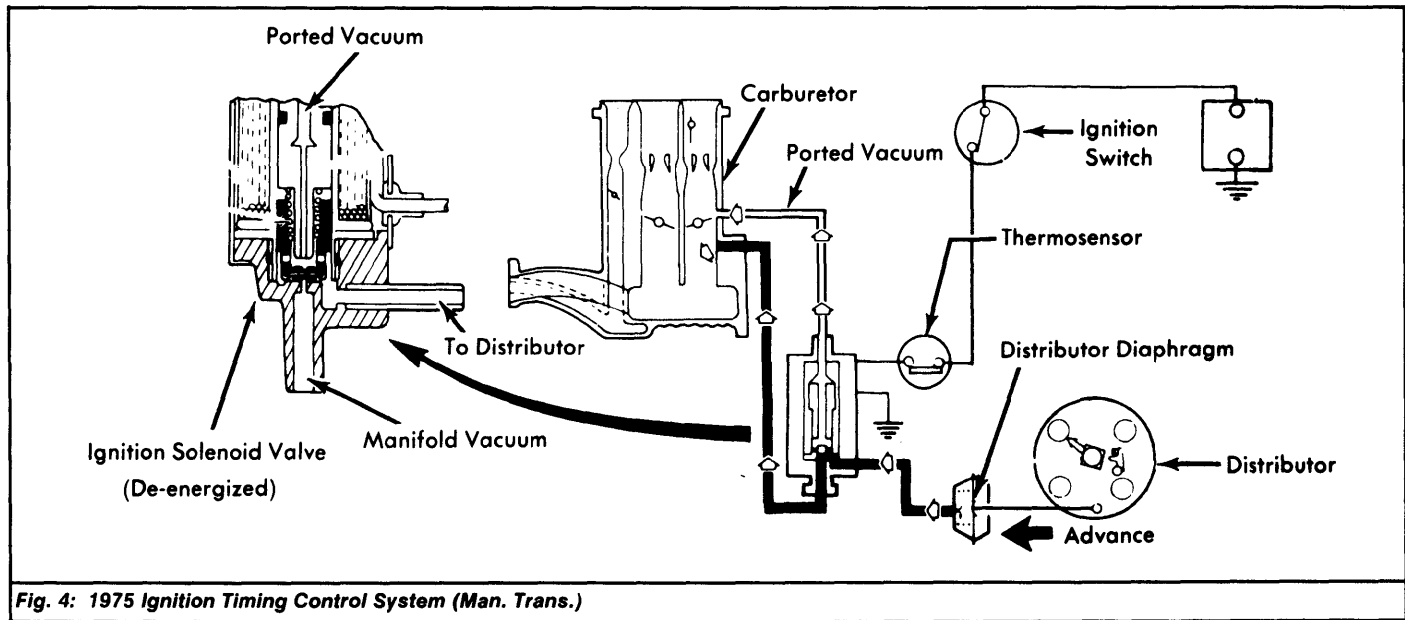

Fig. 4: 1975 Ignition Timing Control System (Man. Trans.)

1974-79 EXHAUST EMISSION SYSTEMS Honda Vacuum Diagrams (Cont.)

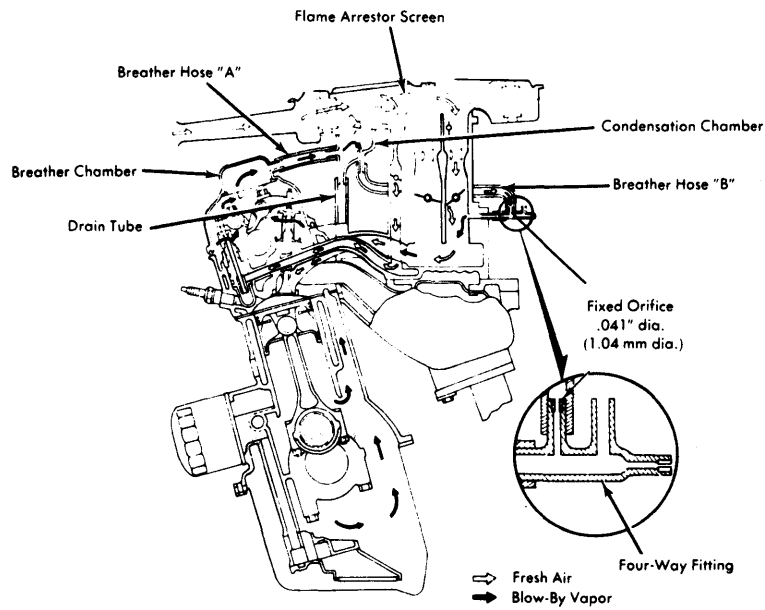

Fig. 5: 1975-76 Positive Crankcase Ventilation System (Typical)

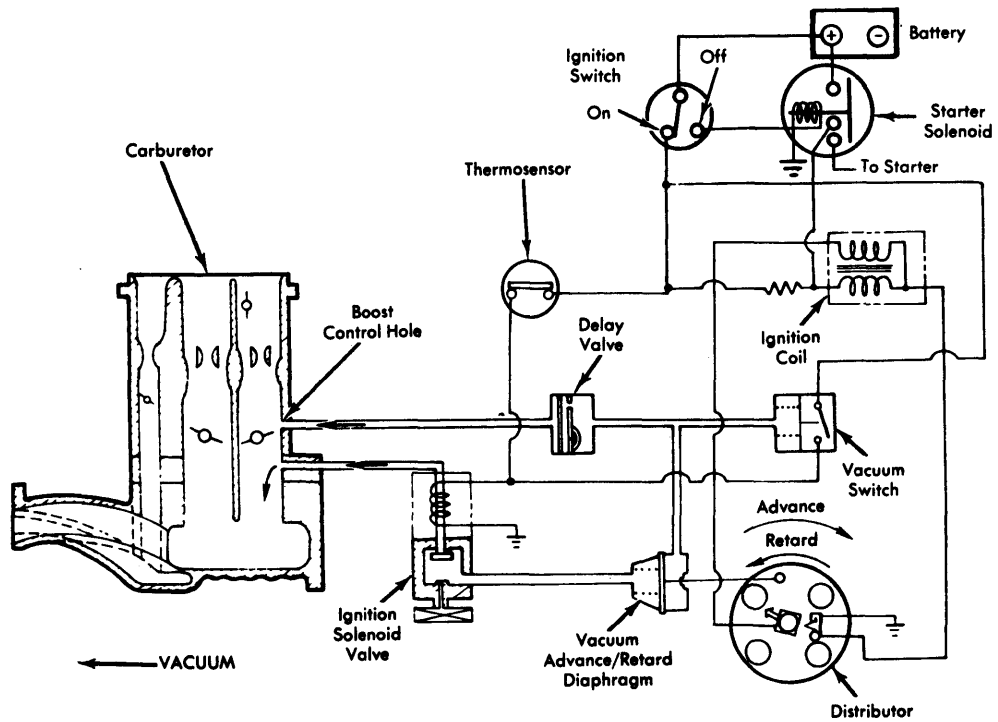

Fig. 6: 1976 Ignition Timing Control System (Auto. Trans.)

1974-79 EXHAUST EMISSION SYSTEMS

Honda Vacuum Diagrams (Cont.)

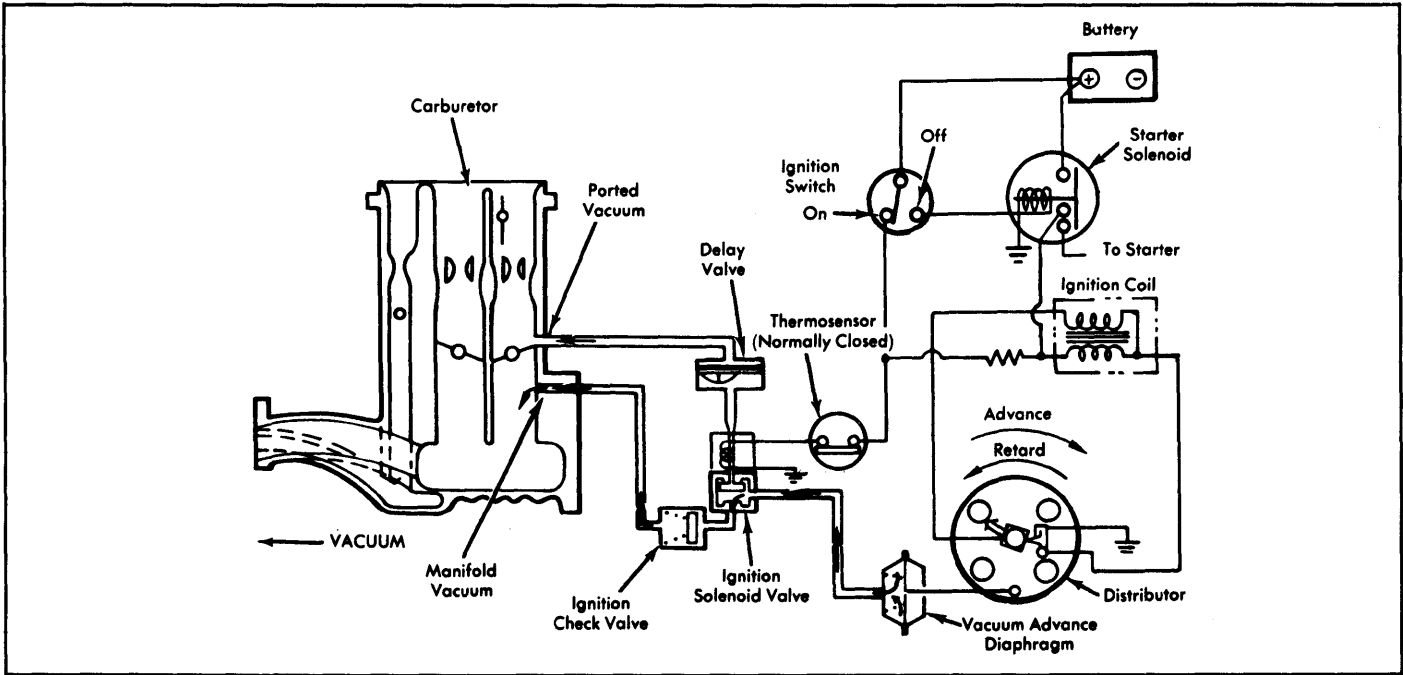

Fig. 7: 1976 Ignition Timing Control System (Man. Trans.)

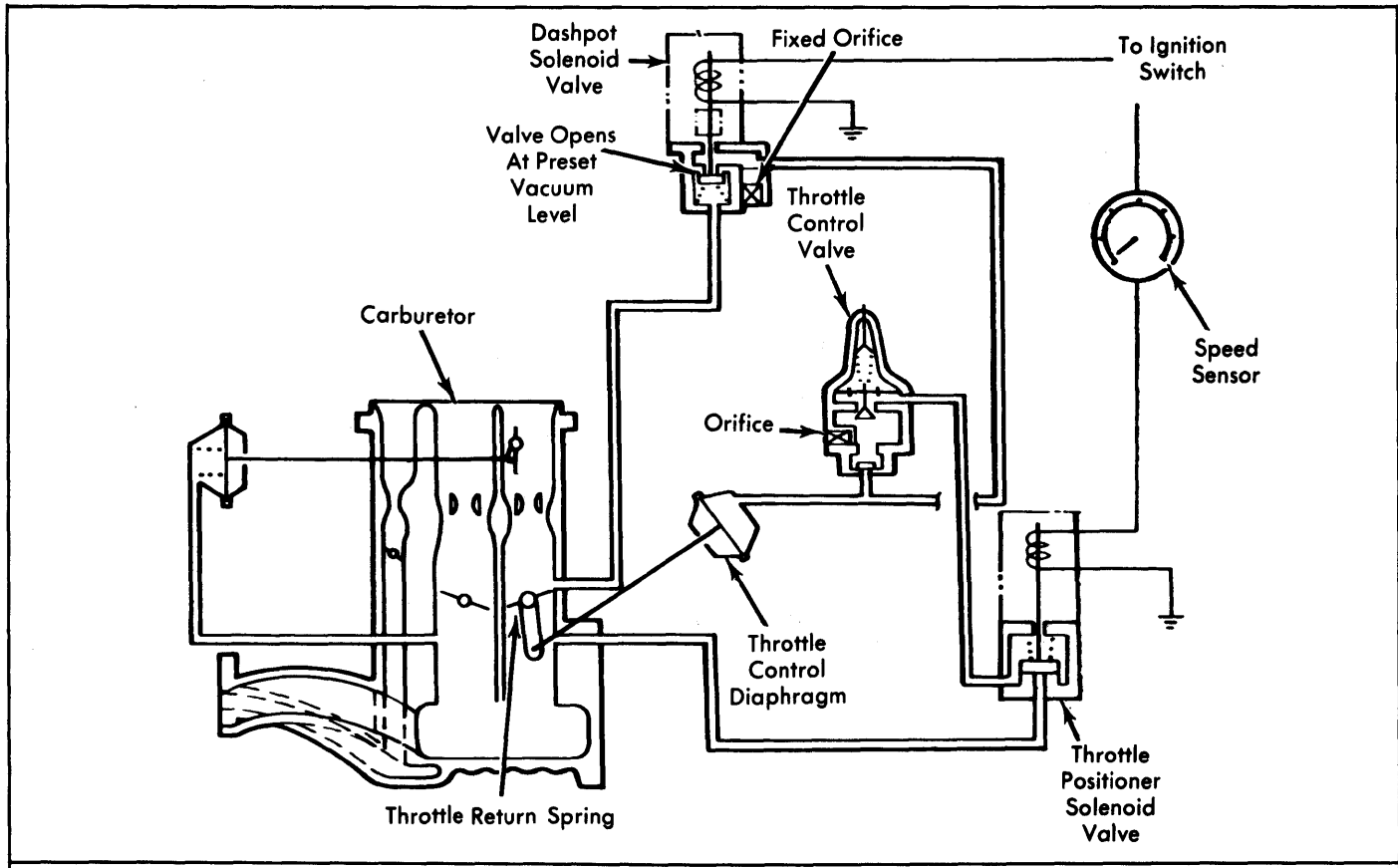

Fig. 8: 1976 Throttle Positioner System

1974-79 EXHAUST EMISSION SYSTEMS

Honda Vacuum Diagrams (Cont.)

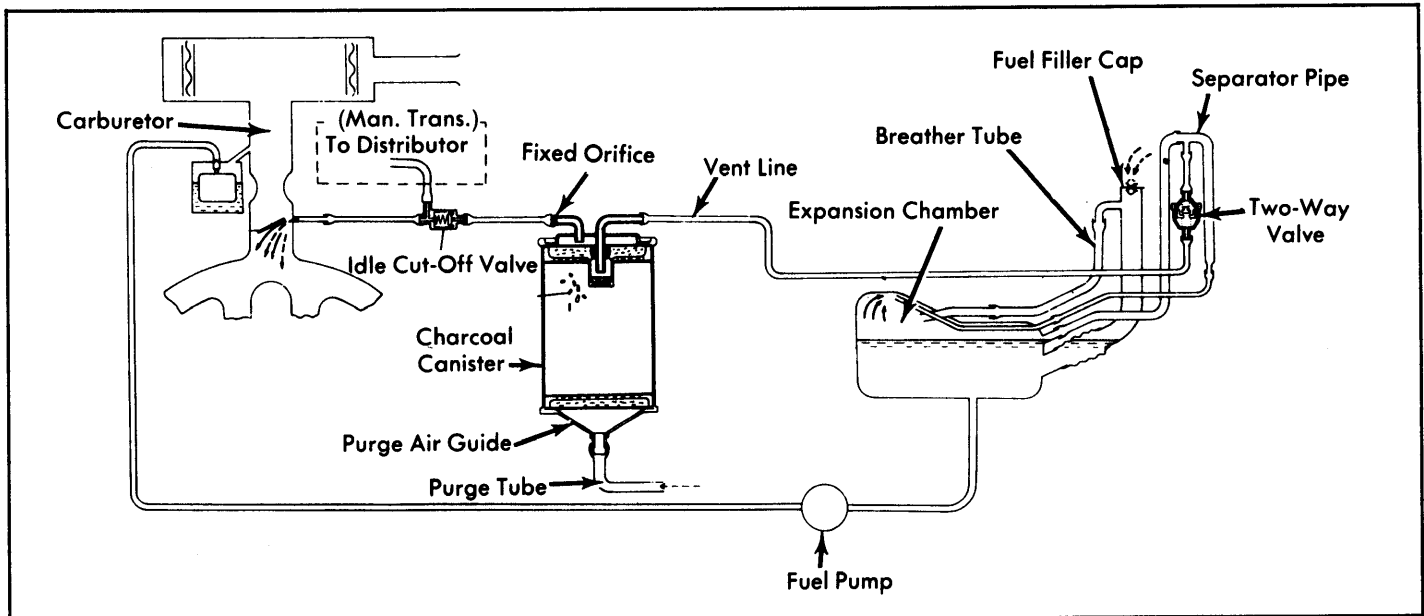

Fig. 9: 1977 Fuel Evaporation System

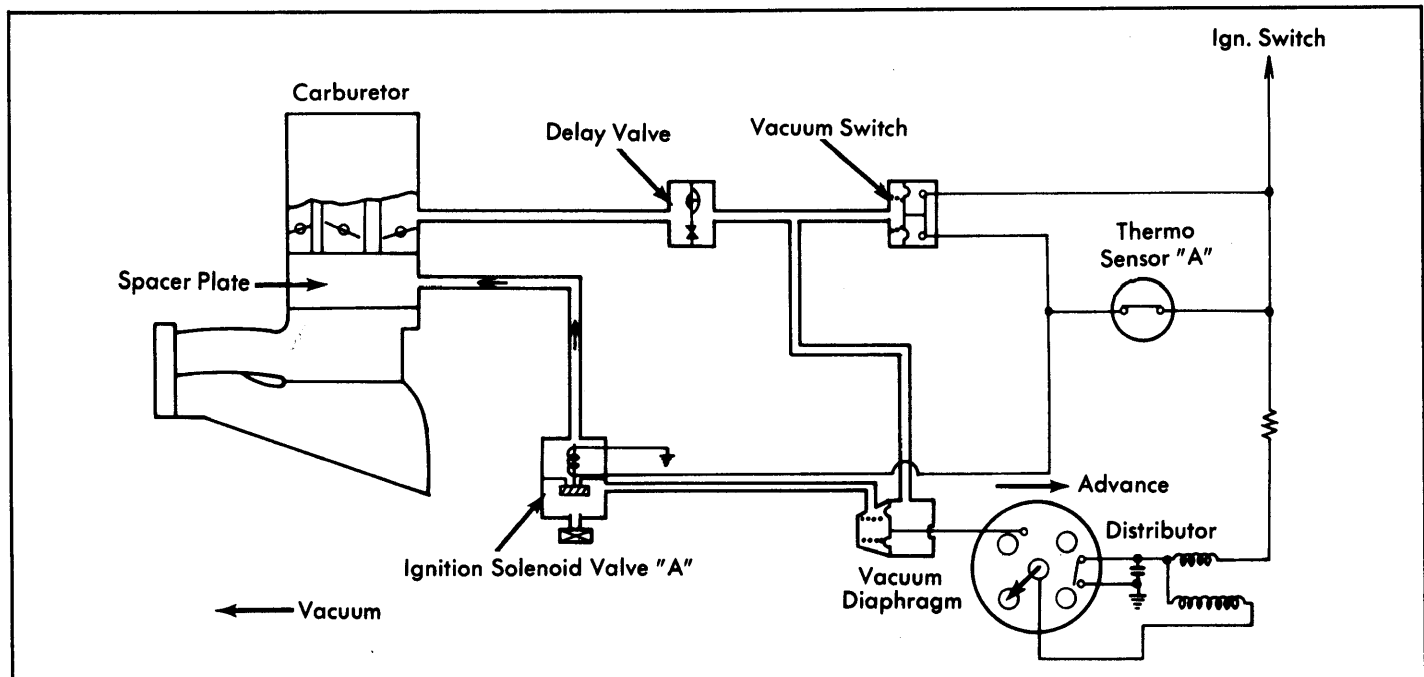

Fig. 10: 1977 Ignition Timing Control System (California & High Altitude)

1974-79 EXHAUST EMISSION SYSTEMS

Honda Vacuum Diagrams (Cont.)

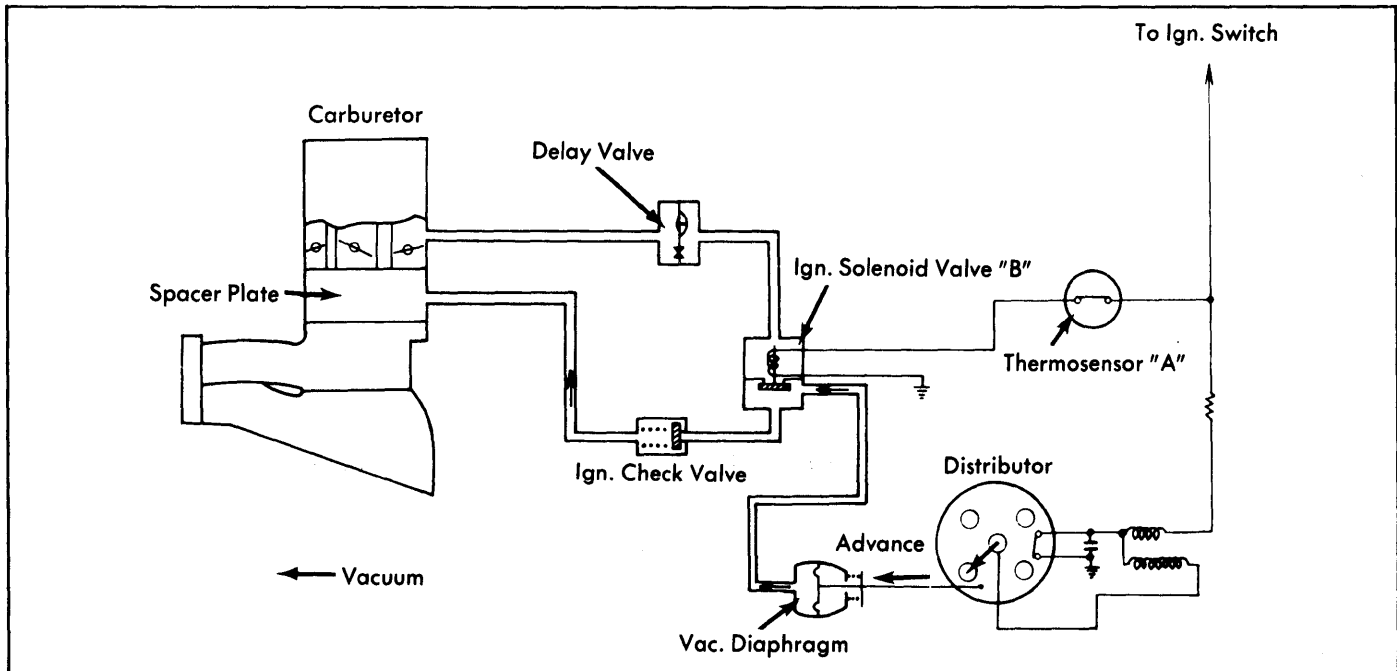

Fig. 11: 1977 Ignition Timing Control System (Federal Auto. Trans. & All Man. Trans.)

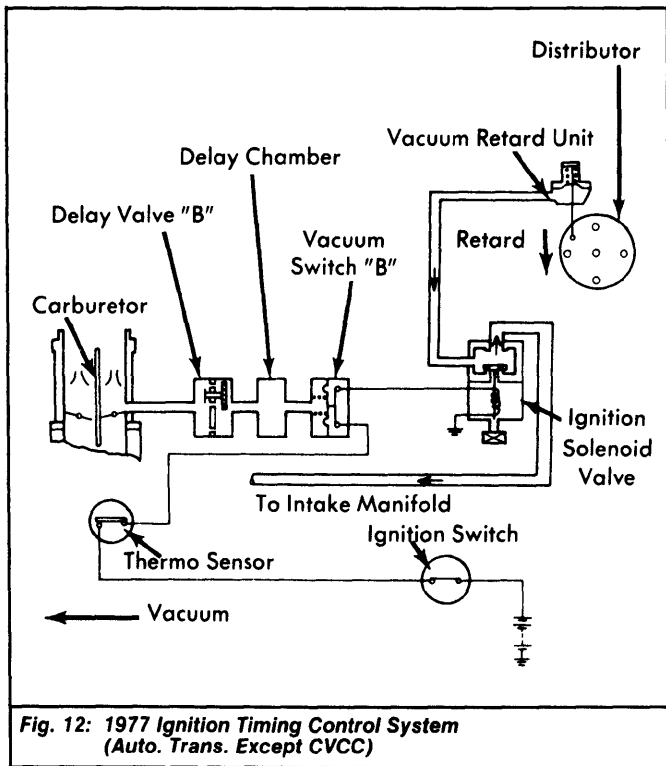

Fig. 12: 1977 Ignition Timing Control System (Auto. Trans. Except CVCC)

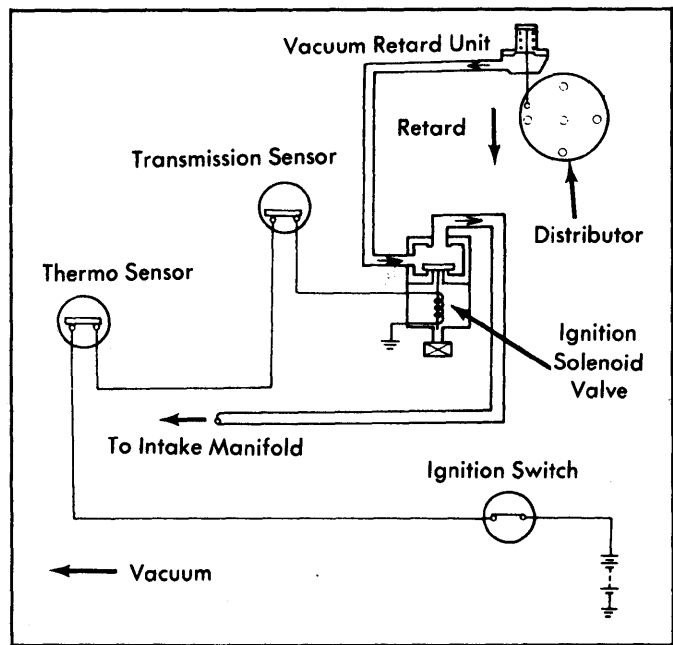
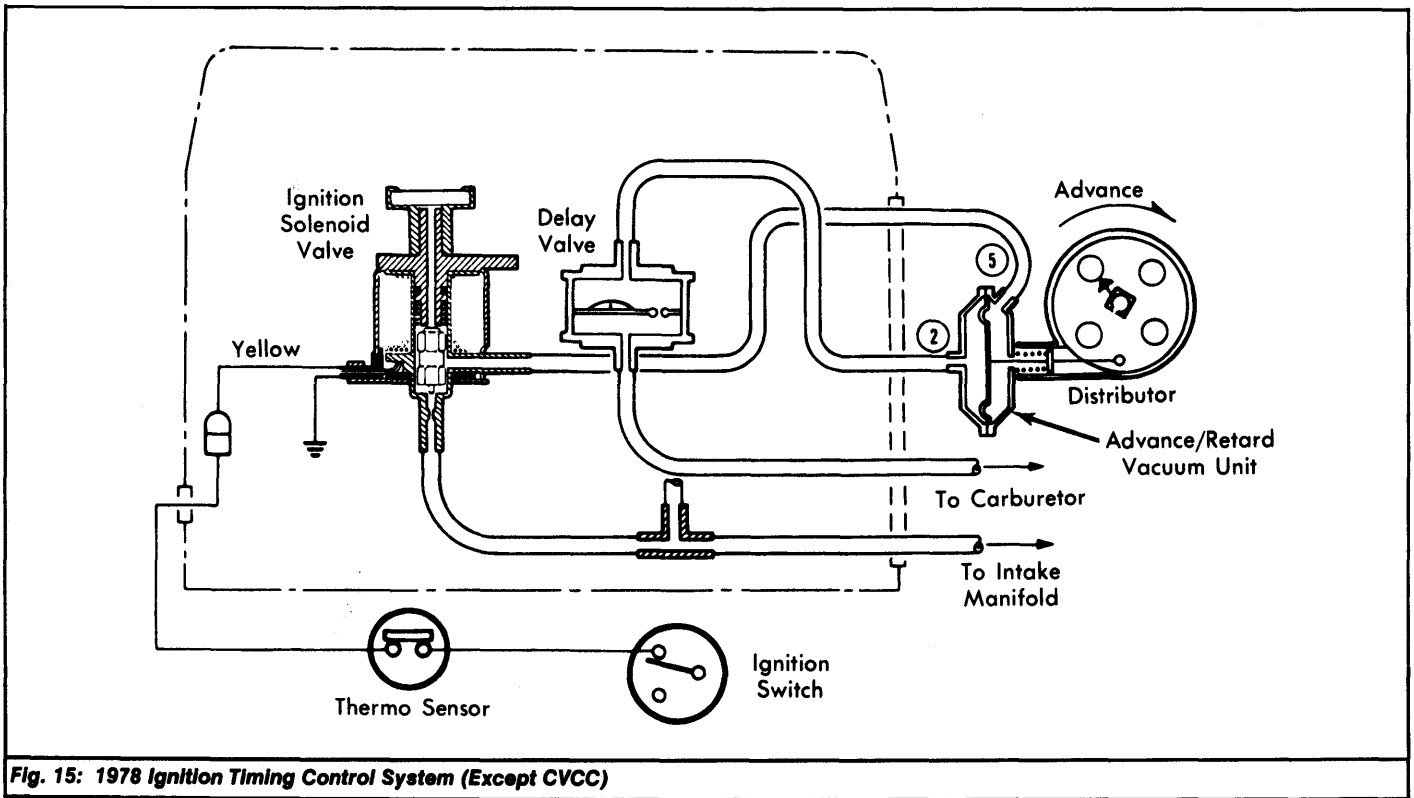
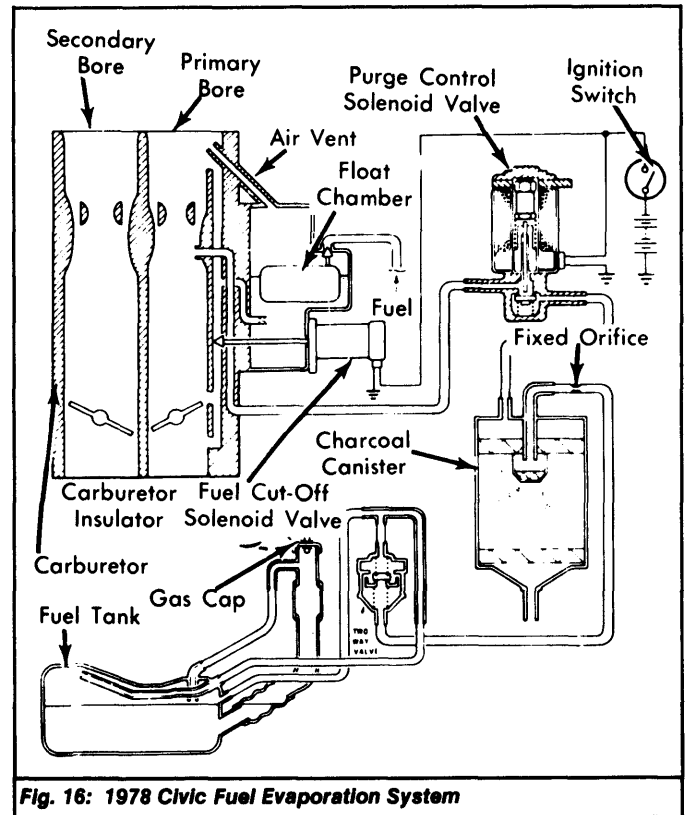
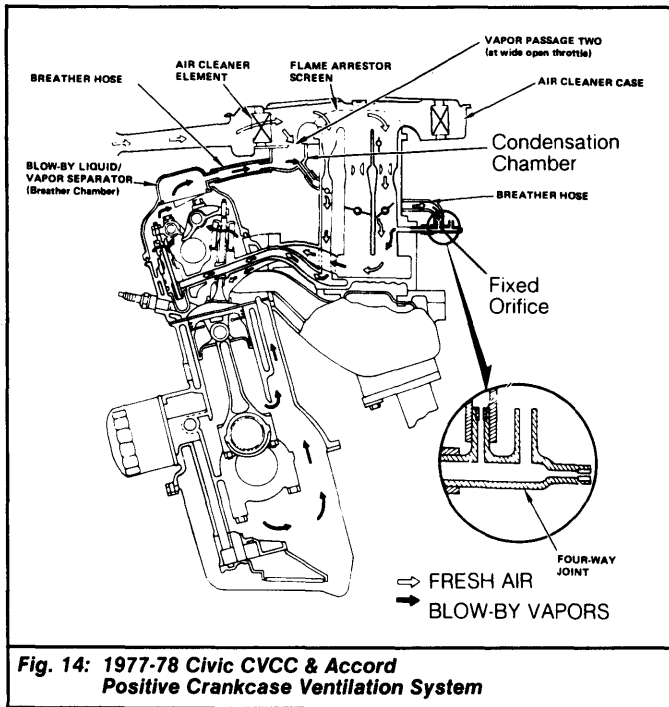

Fig. 13: 1977 Ignition Timing Control System (Man. Trans. Except CVCC)

1974-79 EXHAUST EMISSION SYSTEMS

Honda Vacuum Diagrams (Cont.)



1974-79 EXHAUST EMISSION SYSTEMS Honda Vacuum Diagrams (Cont.)

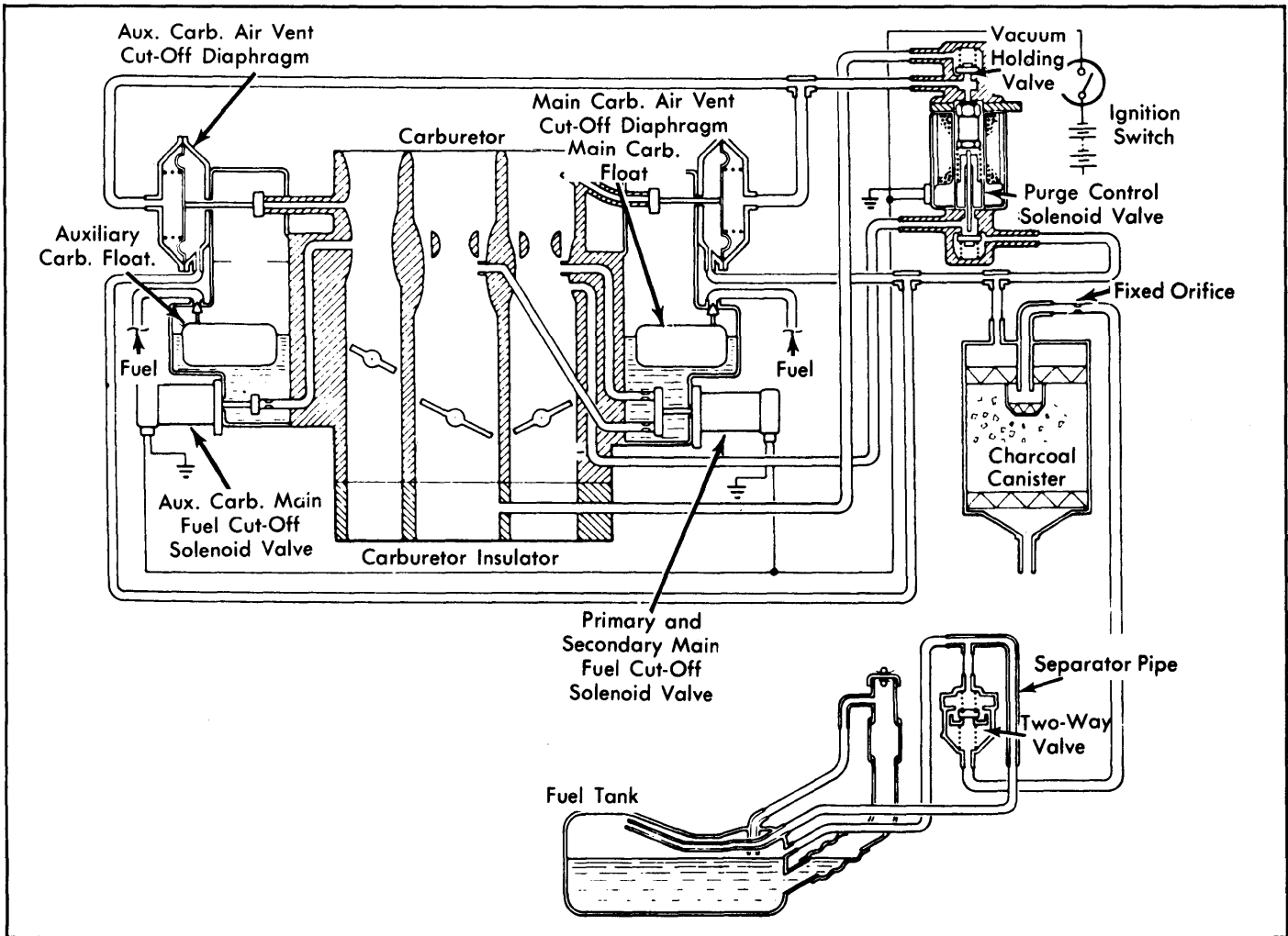

Fig. 17: 1978 Civic CVCC & Accord Fuel Evaporation System

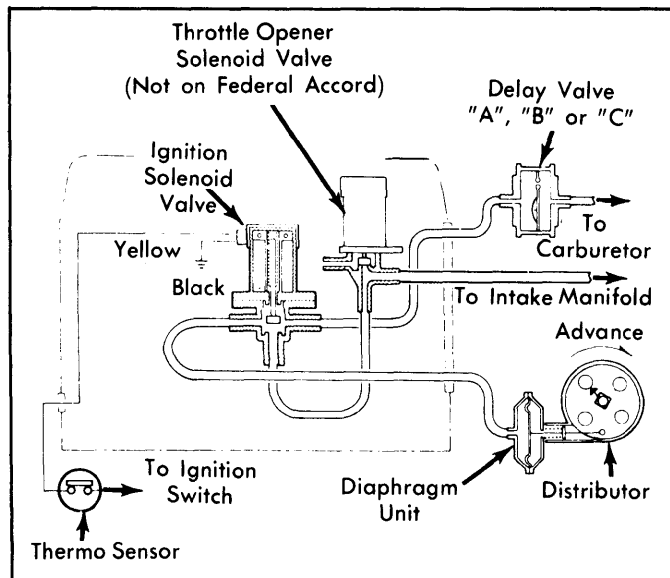

Fig. 18: 1978 Ignition Timing Control System (Federal Auto. Trans. Accord & All Man. Trans. Models)

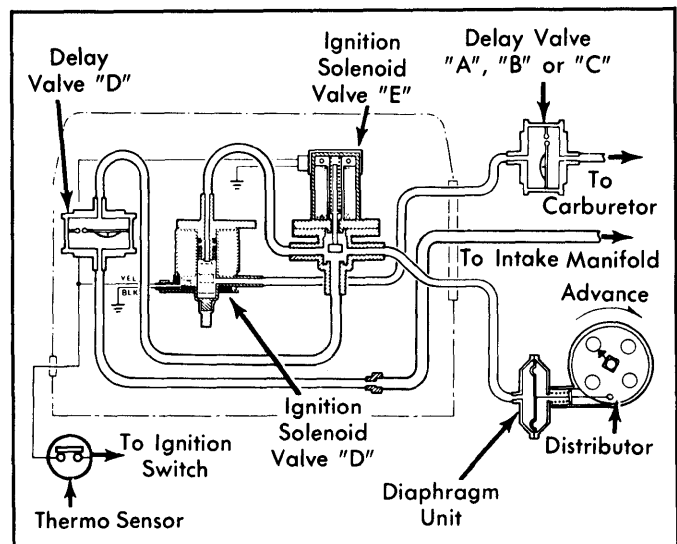

Fig. 19: 1978 Ignition Timing Control System (Federal Auto. Trans. Wagon & Auto. Trans. Civic Sedan)

1974-79 EXHAUST EMISSION SYSTEMS

Honda Vacuum Diagrams (Cont.)

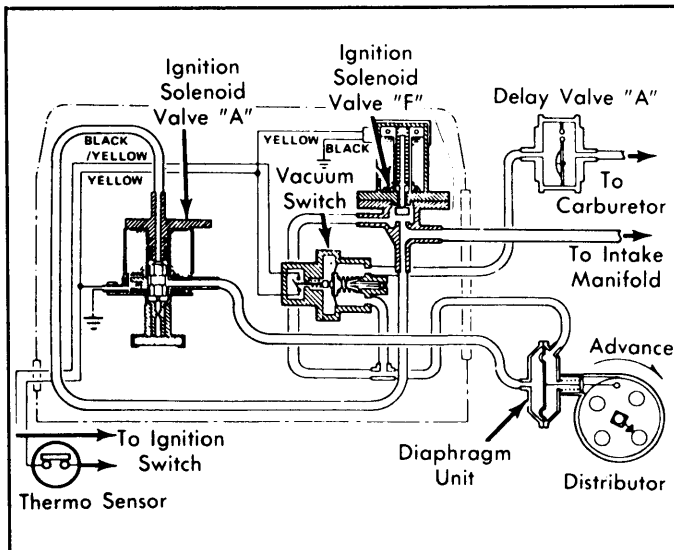

Fig. 20: 1978 Ignition Timing Control System (Calif. & High Altitude Auto. Trans. Accord)

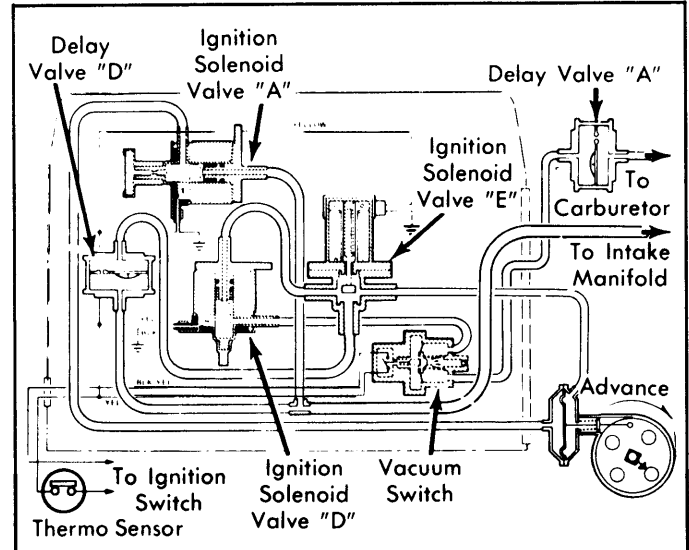

Fig. 22: 1978 Ignition Timing Control System (Calif. & High Altitude Auto. Trans. Civic Wagon)

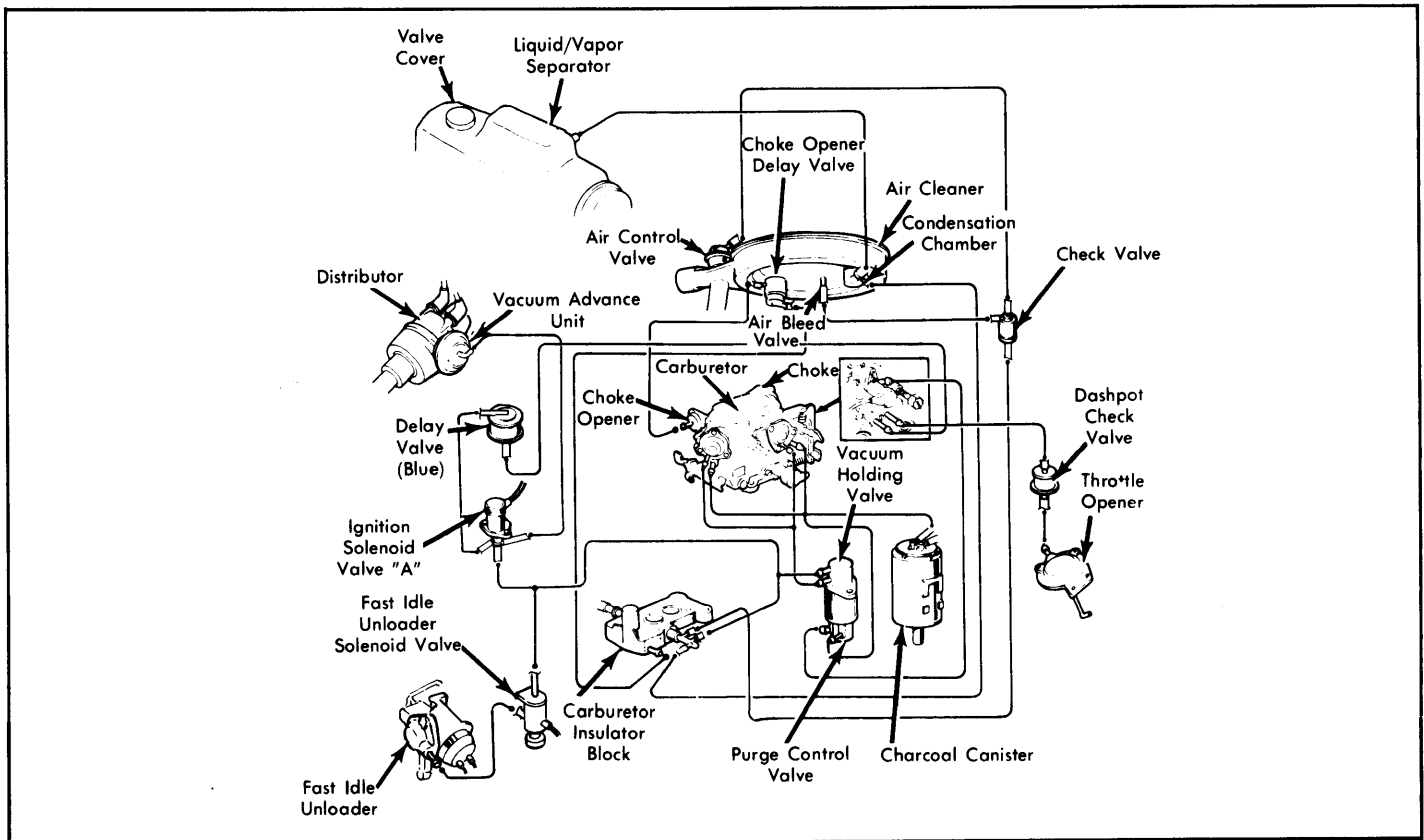

Fig. 21: 1979 Accord & Prelude Exhaust Emission System (Federal)

1974-79 EXHAUST EMISSION SYSTEMS

Honda Vacuum Diagrams (Cont.)

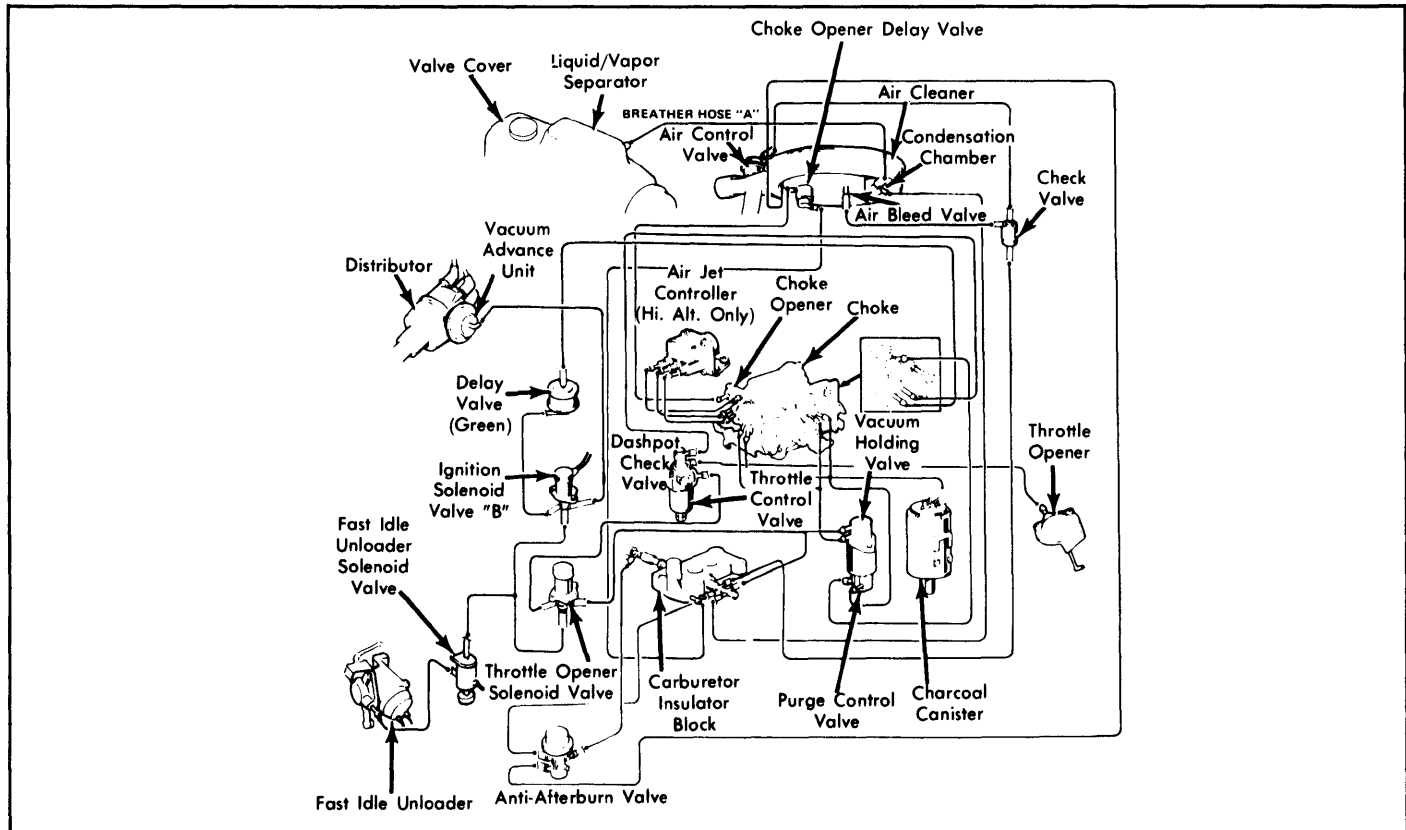

Fig. 23: 1979 Accord & Prelude Exhaust Emission System (Calif. & High Altitude Man. Trans.)

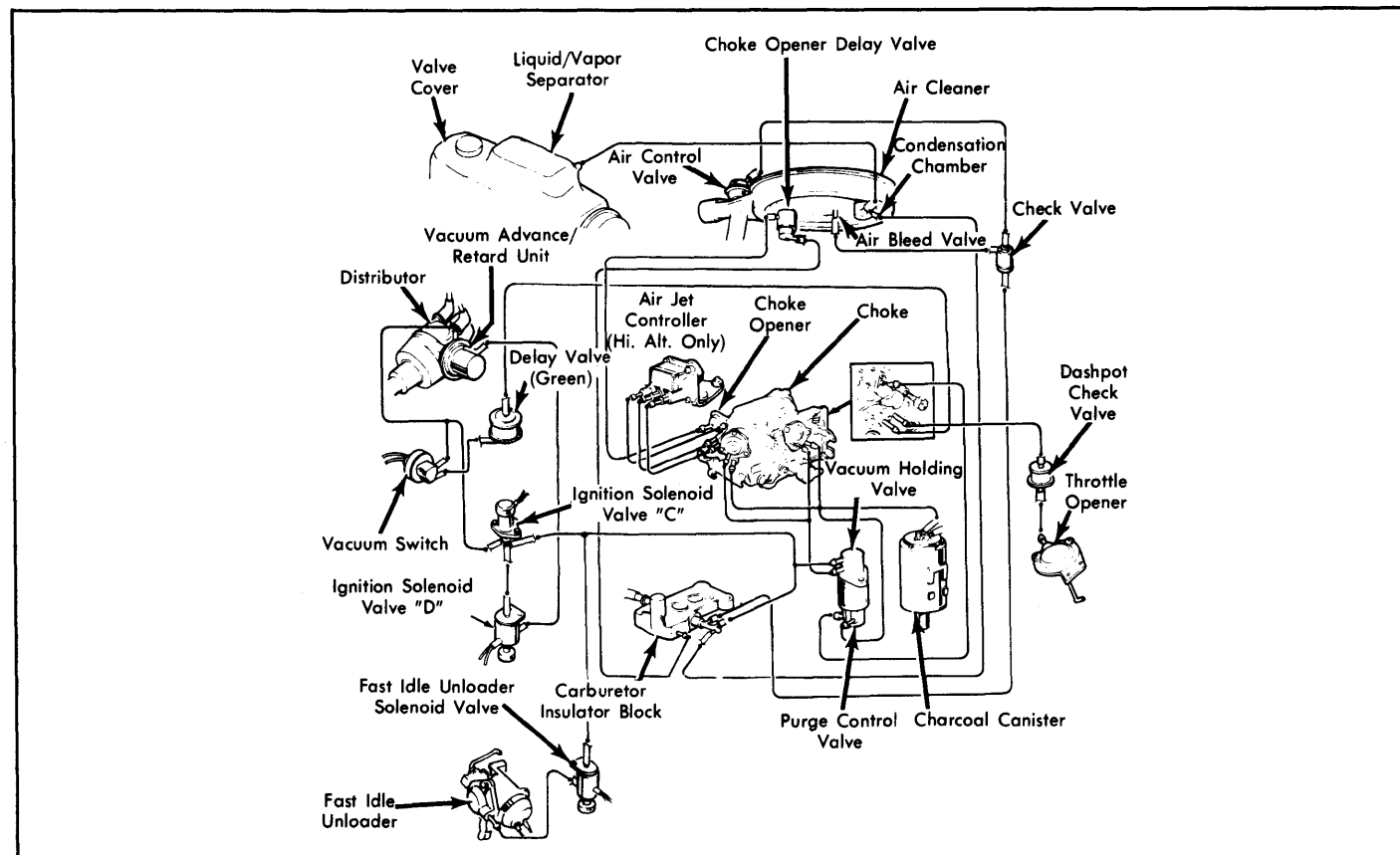

Fig. 24: 1979 Accord & Prelude Exhaust Emission System (Calif. & High Altitude Auto. Trans.)

1974-79 EXHAUST EMISSION SYSTEMS

Honda Vacuum Diagrams (Cont.)

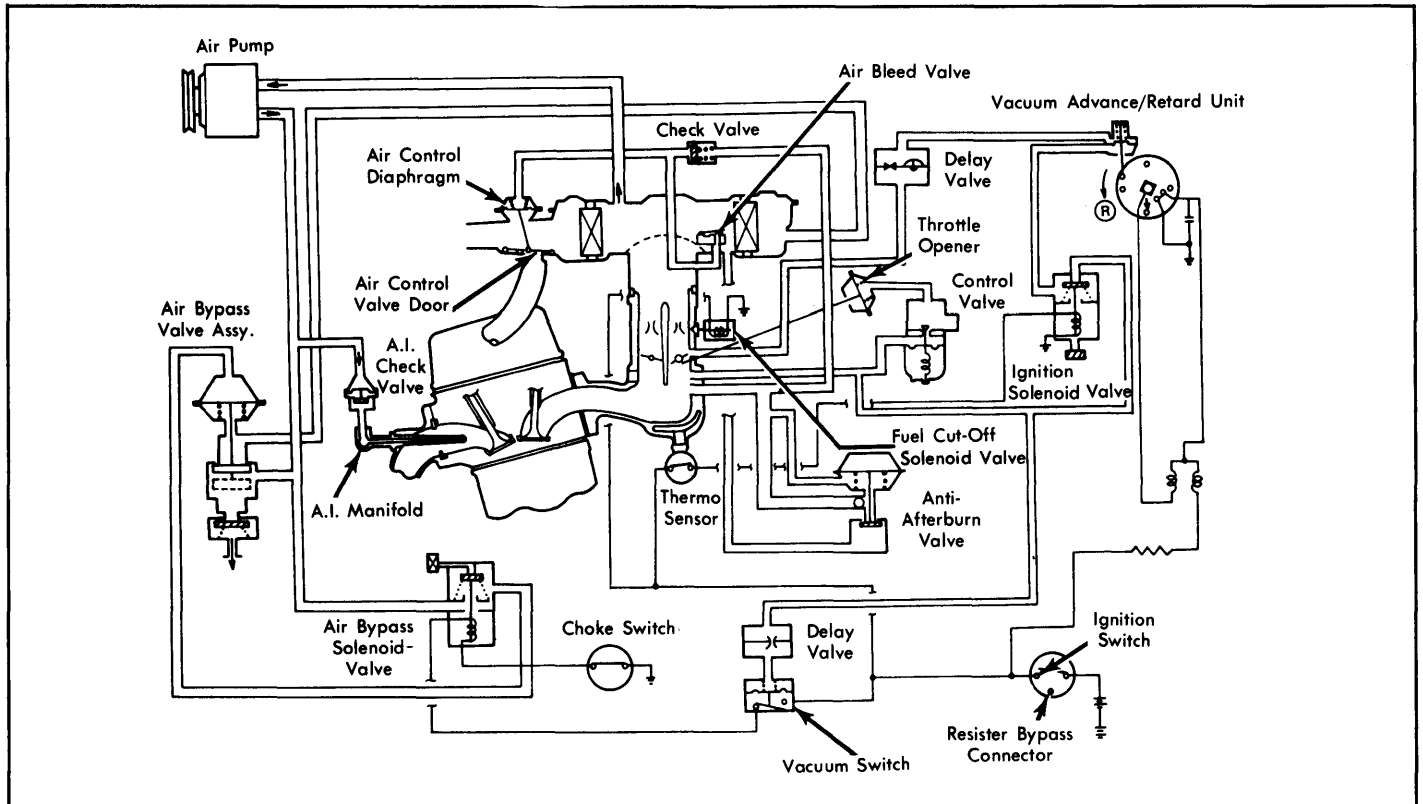

Fig. 25: 1979 Civic 1200 Exhaust Emission System (Man. Trans.)

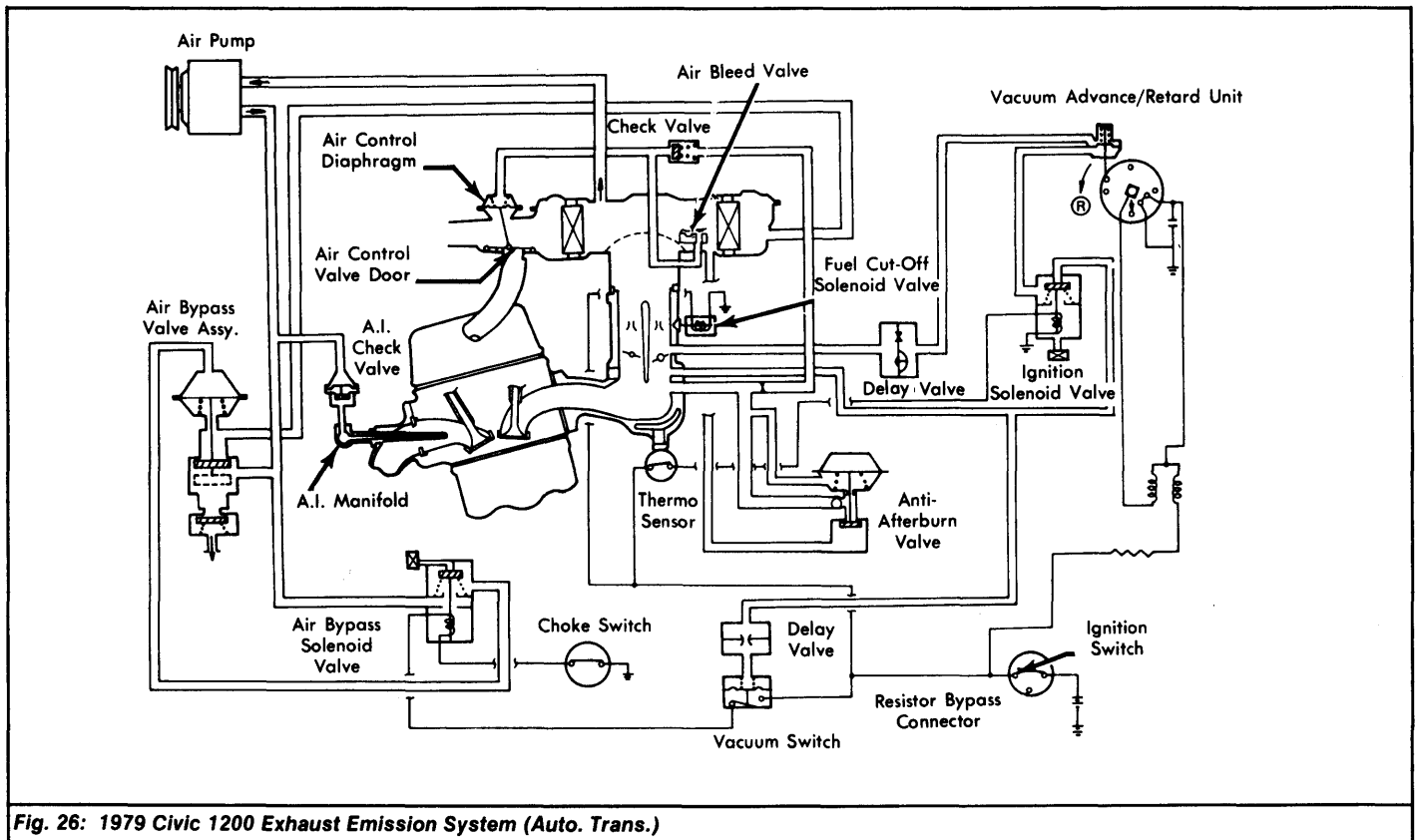

Fig. 26: 1979 Civic 1200 Exhaust Emission System (Auto. Trans.)

1974-79 EXHAUST EMISSION SYSTEMS Honda Vacuum Diagrams (Cont.)

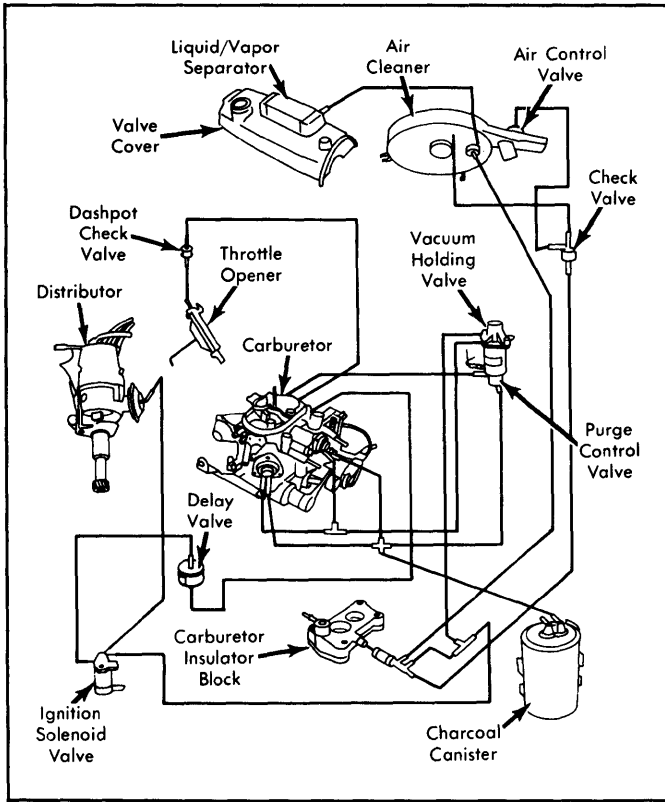

Fig. 27: 1979 Civic CVCC Exhaust Emission System (Federal Man. Trans.)

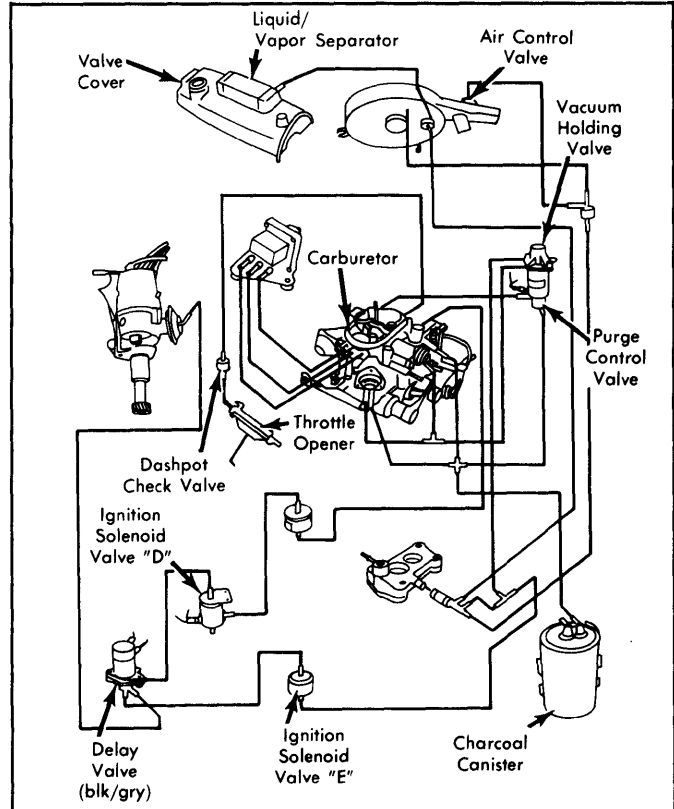

Fig. 29: 1979 Civic CVCC Exhaust Emission System (Auto. Trans. Except Calif. & High Alt. Wagon)

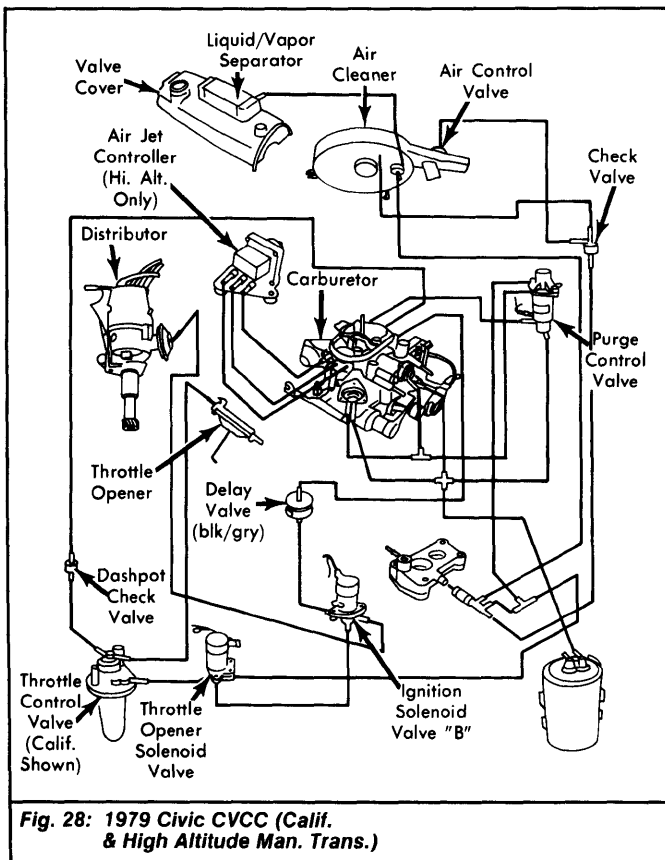

Fig. 28: 1979 Civic CVCC (Calif. & High Altitude Man. Trans.)

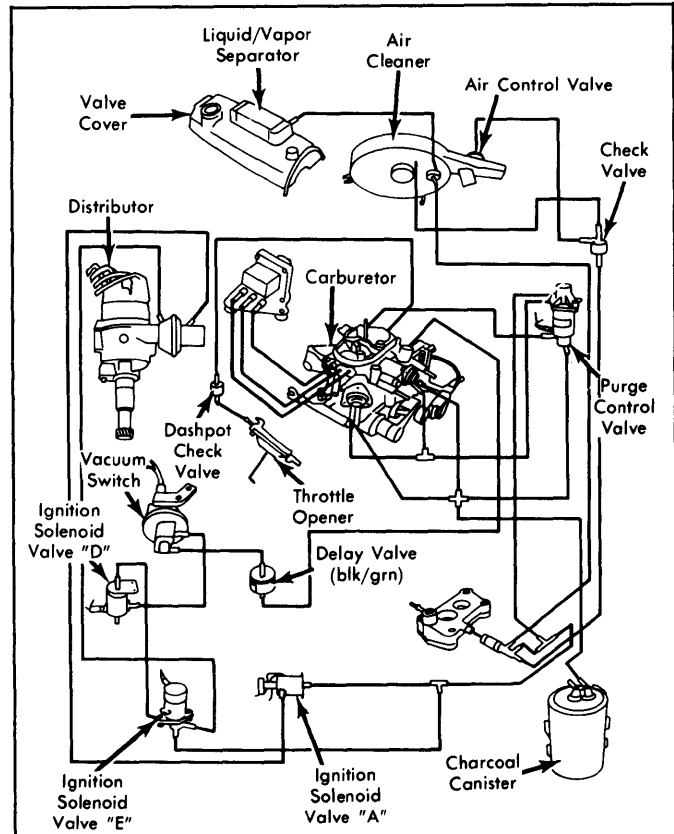

Fig. 30: 1979 Civic CVCC Station Wagon Exhaust Emission System (Calif. & High Altitude Auto. Trans.)