

1974-79 EXHAUST EMISSION SYSTEMS

Ford Motor Co. Vacuum Diagrams

Courier

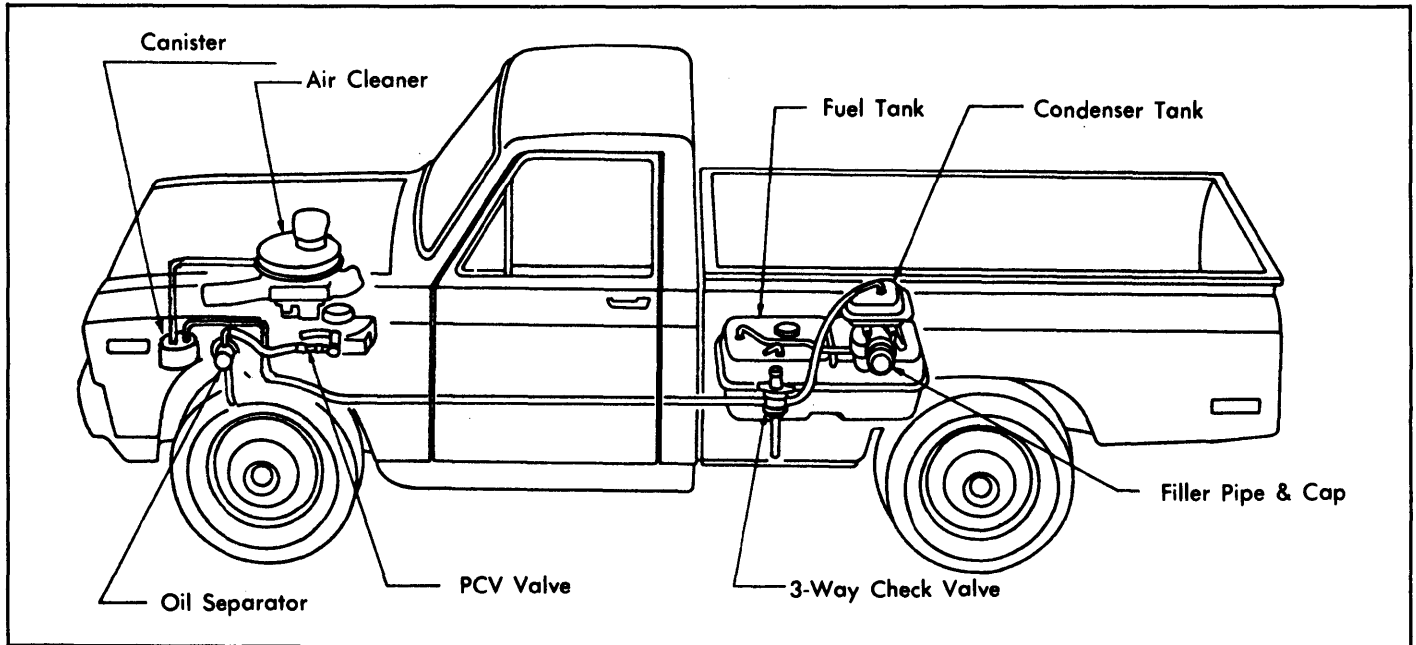

Fig. 1: 1974-76 Fuel Evaporation System

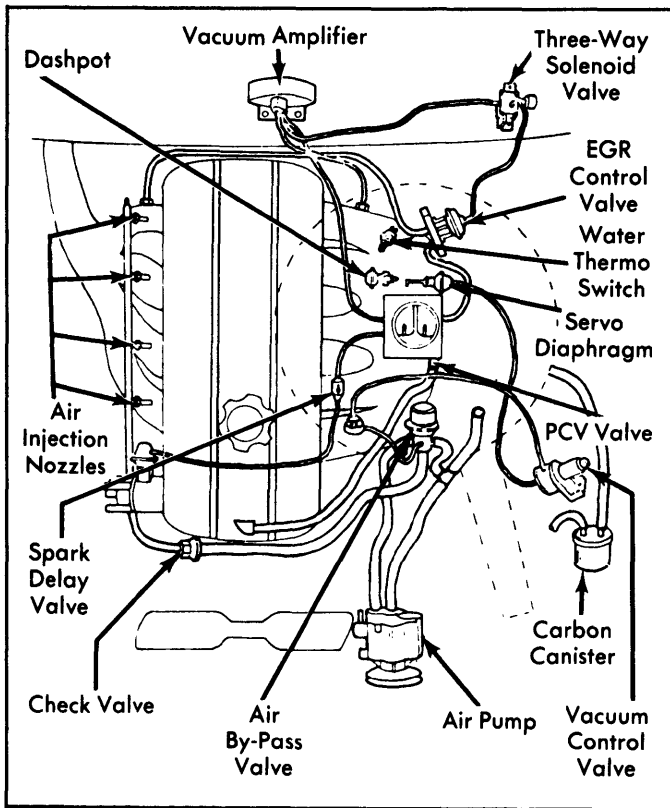

Fig. 2: 1977 1.8L Exhaust Emission System (Except California)

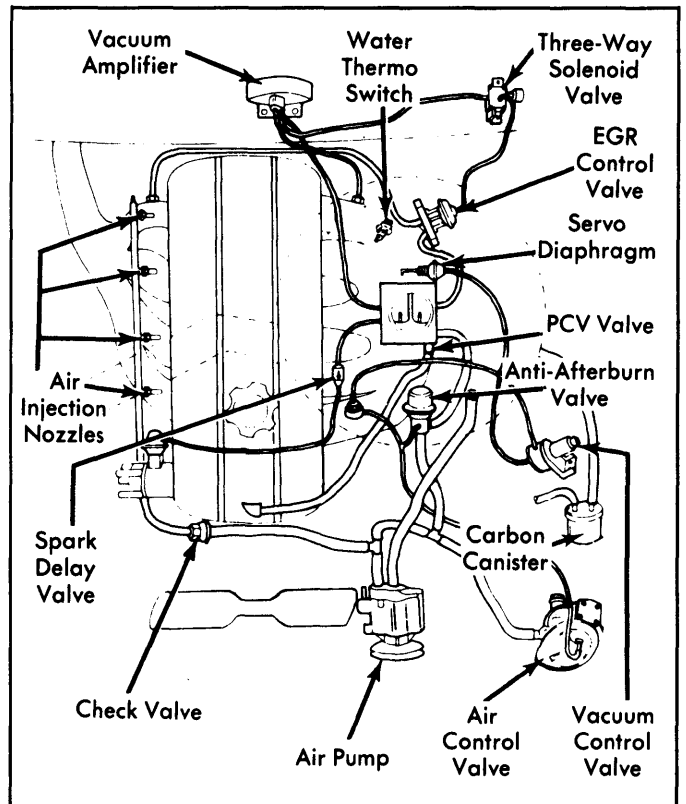

Fig. 3: 1977 1.8L Exhaust Emission System (California)

1974-79 EXHAUST EMISSION SYSTEMS Ford Motor Co. Vacuum Diagrams (Cont.)

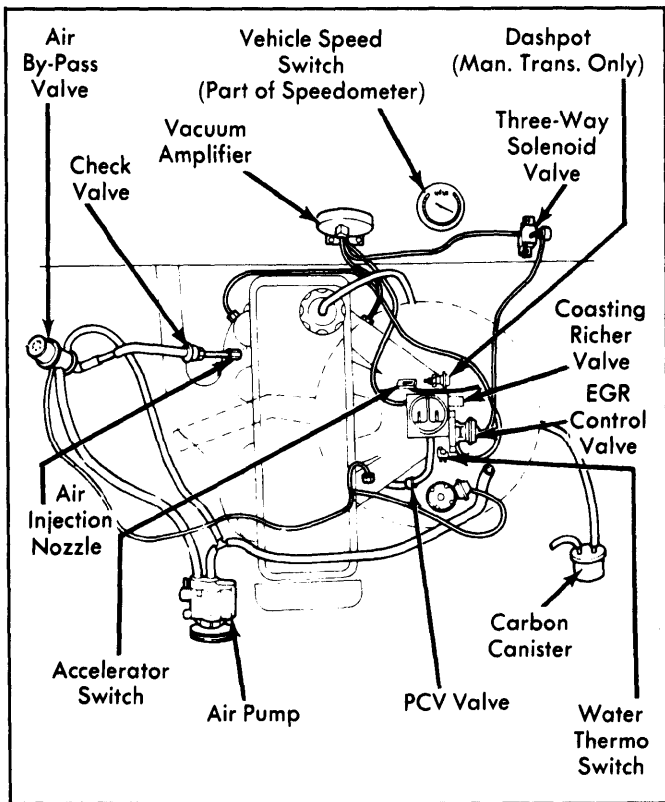

Fig. 4: 1977 2.3L Exhaust Emission System (Except California)

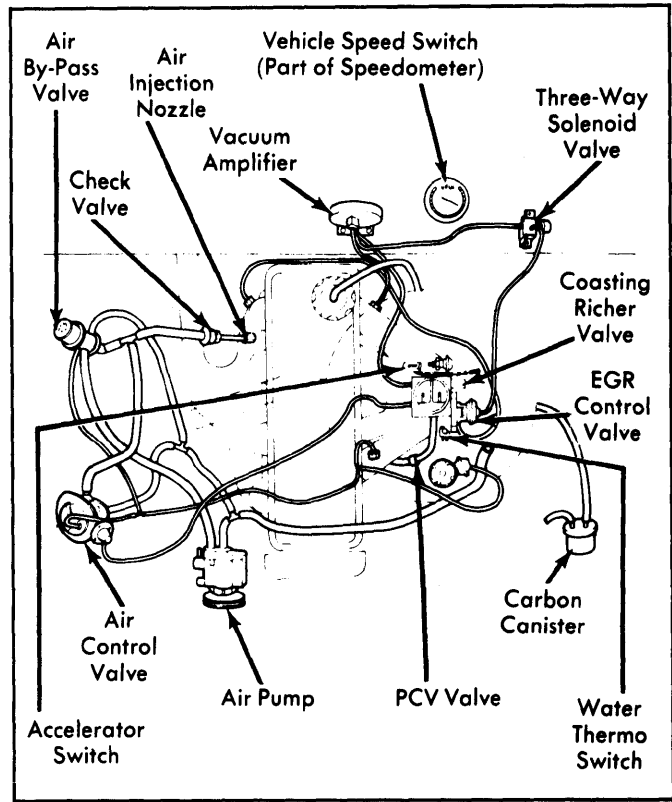

Fig. 6: 1977 2.3L Exhaust Emission System (California)

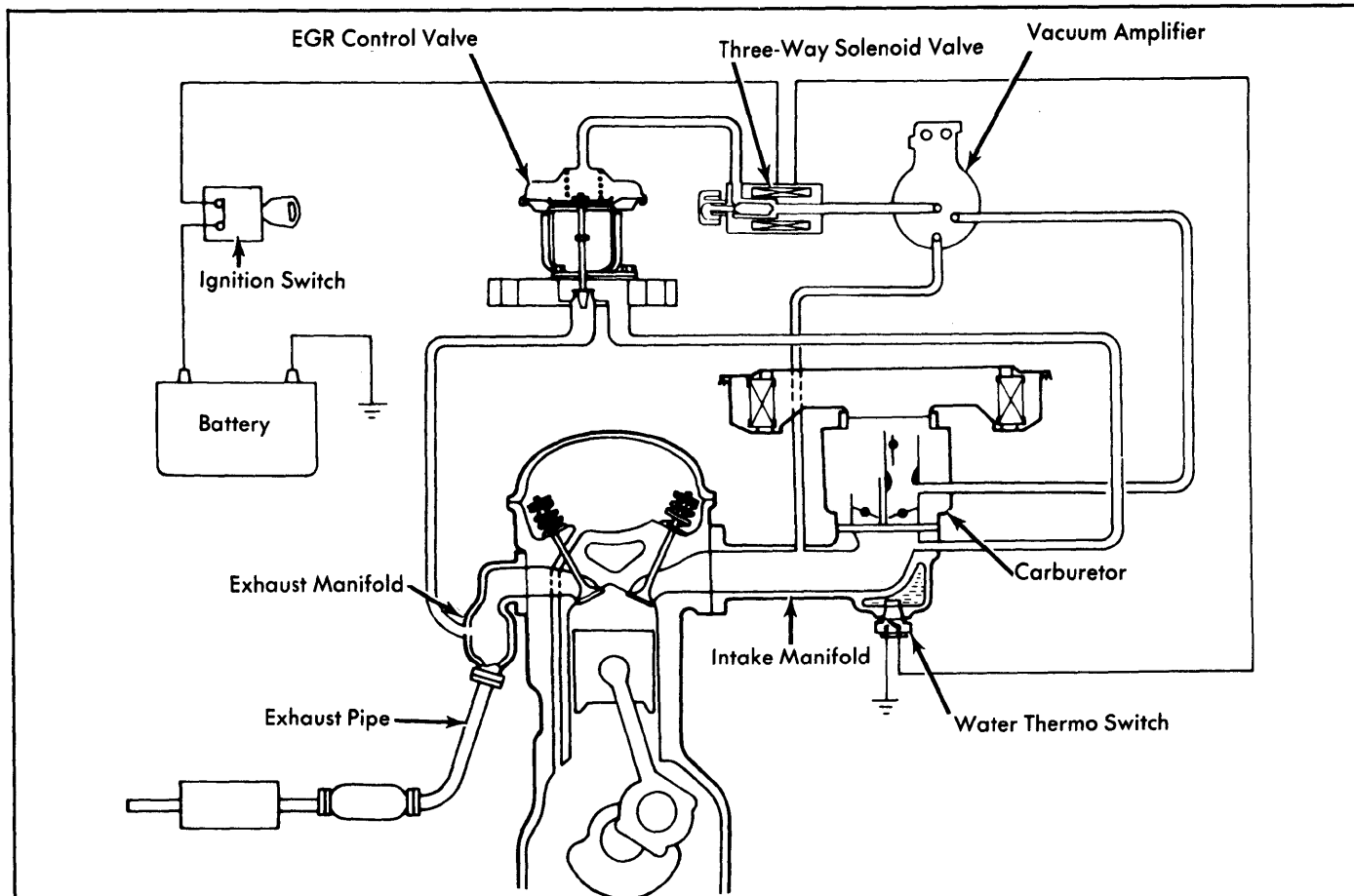

Fig. 5: 1977 Exhaust Gas Recirculation System

1974-79 EXHAUST EMISSION SYSTEMS

Ford Motor Co. Vacuum Diagrams (Cont.)

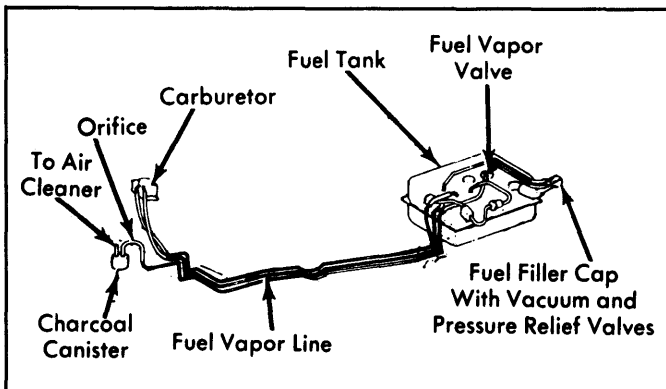

Fig. 7: 1977-78 Fuel Evaporation System

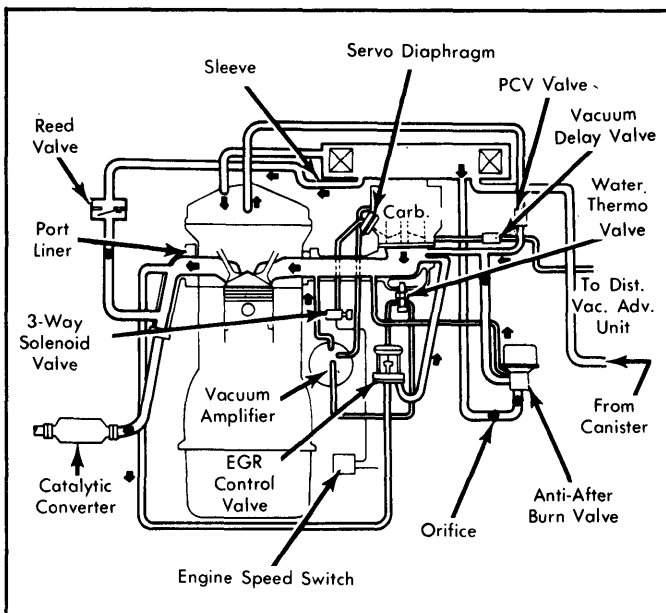

Fig. 8: 1979 2.0L Federal Exhaust Emission System

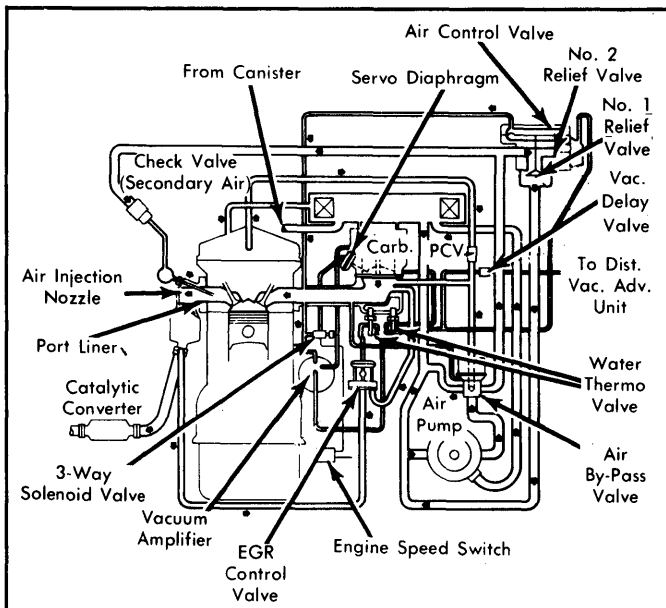

Fig. 9: 1979 2.0L California Exhaust Emission System

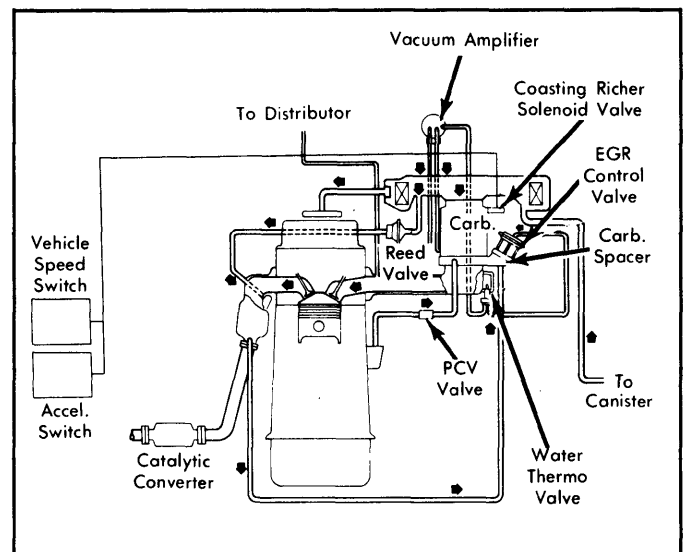

Fig. 10: 1979 2.3L Federal Exhaust Emission System

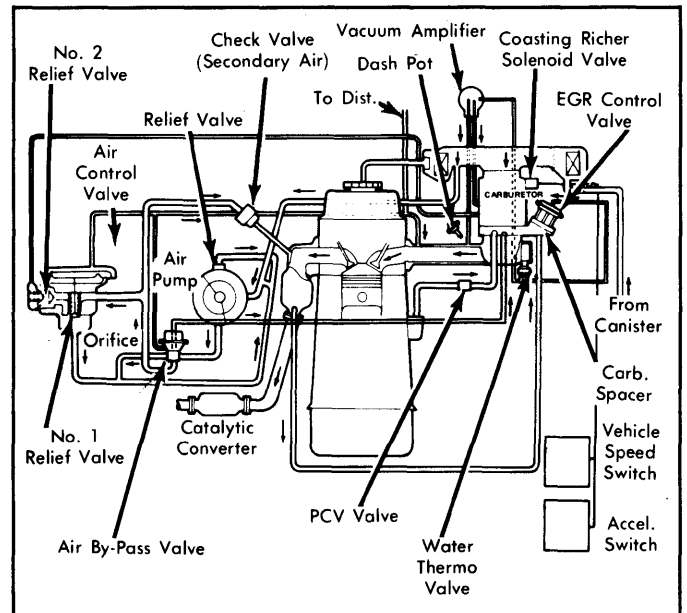

Fig. 11: 1979 2.3L California Exhaust Emission System