

1974-79 EXHAUST EMISSION SYSTEMS Ford Motor Co. Vacuum Diagrams

1975-78 Capri, Capri II

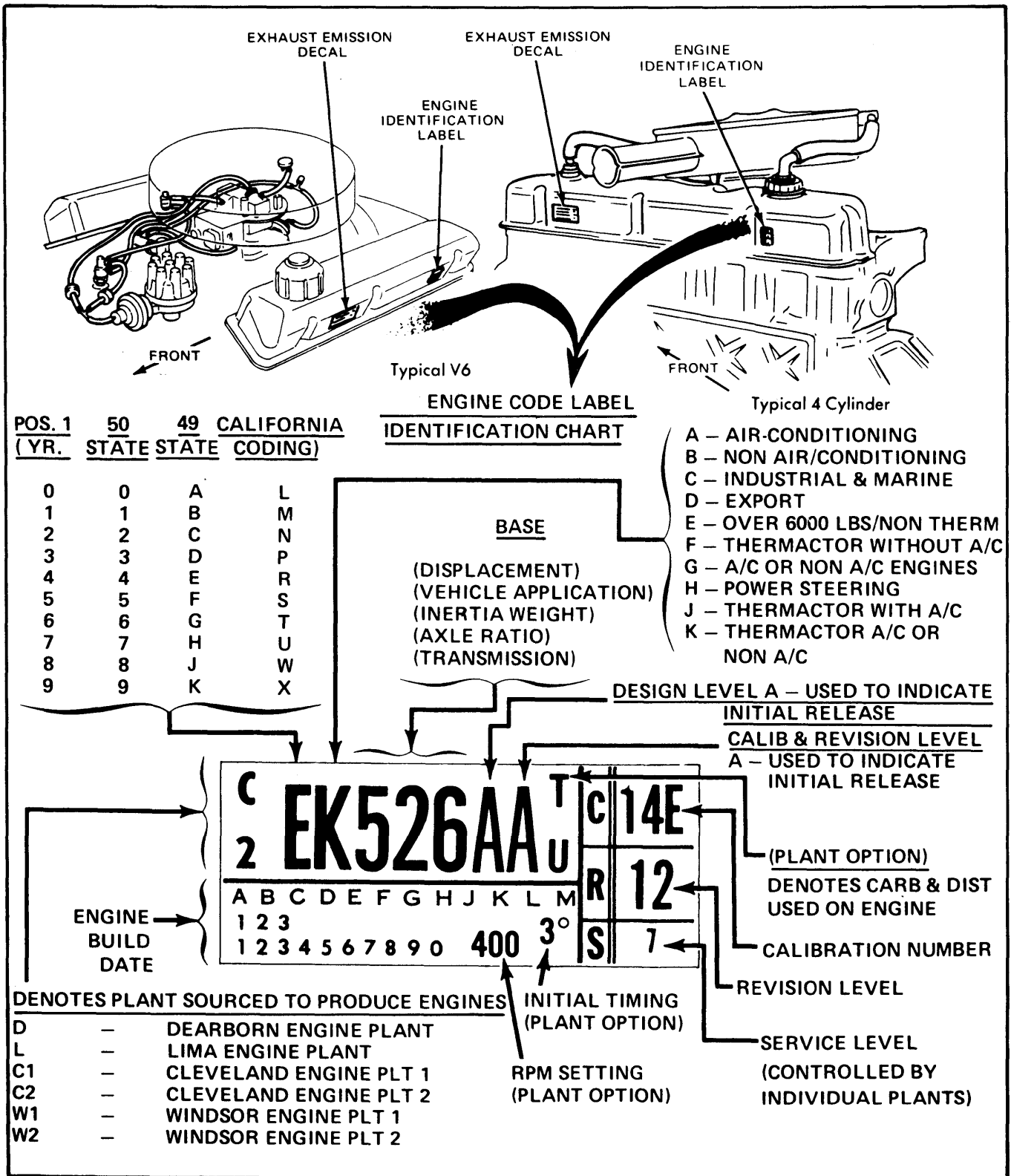

1974-79 EXHAUST EMISSION SYSTEMS Ford Motor Co. Vacuum Diagrams (Cont.)

VACUUM SYSTEM DIAGRAMS				
Vehicle	Transmission	Calibration	Revision	Illus. No.
2300 cc				
Calif., Non-A/C	Auto. Trans.	5-1R	R-2	1
Calif., Non-A/C	Man. Trans.	5-2R	R-2	2
Calif., A/C	Man. Trans.	5-2R	R-1	3
Federal, A/C	Auto. Trans.	5-1D	R-2	4
Federal, Non-A/C	Auto. Trans.	5-1D	R-2	5
Calif., A/C	Auto. Trans.	5-1R	R-2	6
Federal, Non-A/C	Man. Trans.	5-2D	R-1	7
Federal, A/C	Man. Trans.	5-2D	R-1	8
2800 cc				
Federal, Non-A/C	Man. Trans.	5-3J	R-1S	9
Calif., Non-A/C	Man. Trans.	5-3R	R-1	10
Calif., Non-A/C	Auto. Trans.	5-4R	R-1	11
Federal, Non-A/C	Auto. Trans.	5-4J	R-1	12

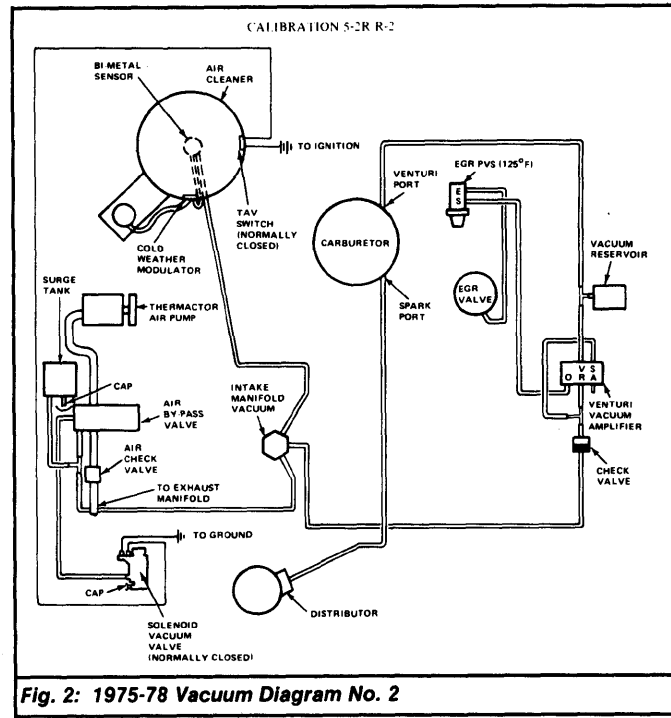
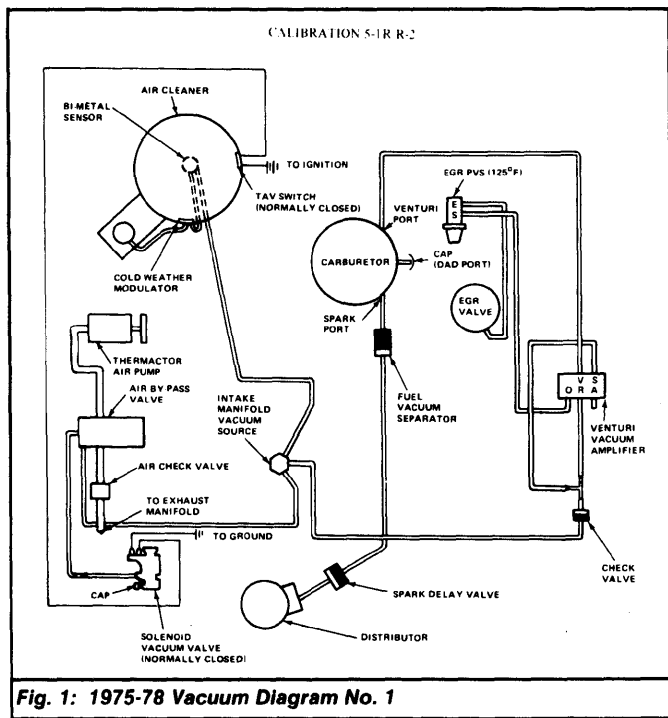

1974-79 EXHAUST EMISSION SYSTEMS Ford Motor Co. Vacuum Diagrams (Cont.)

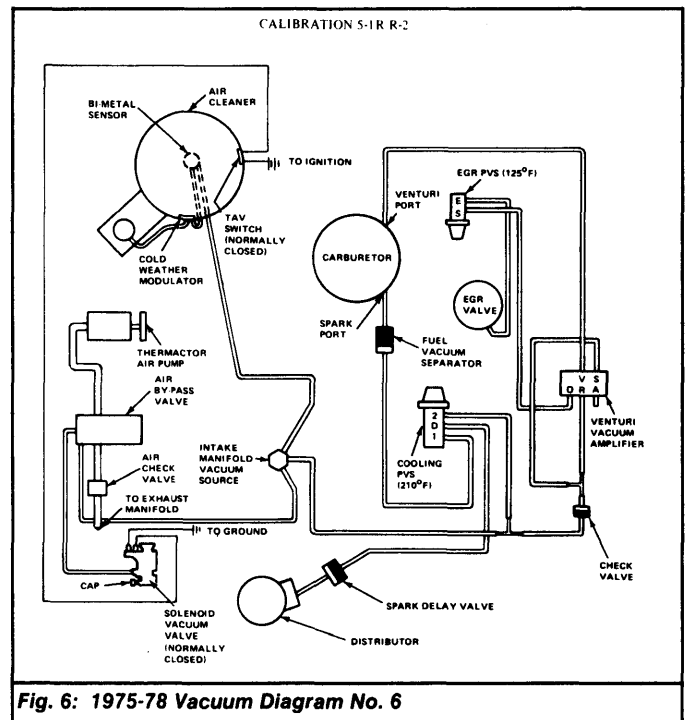
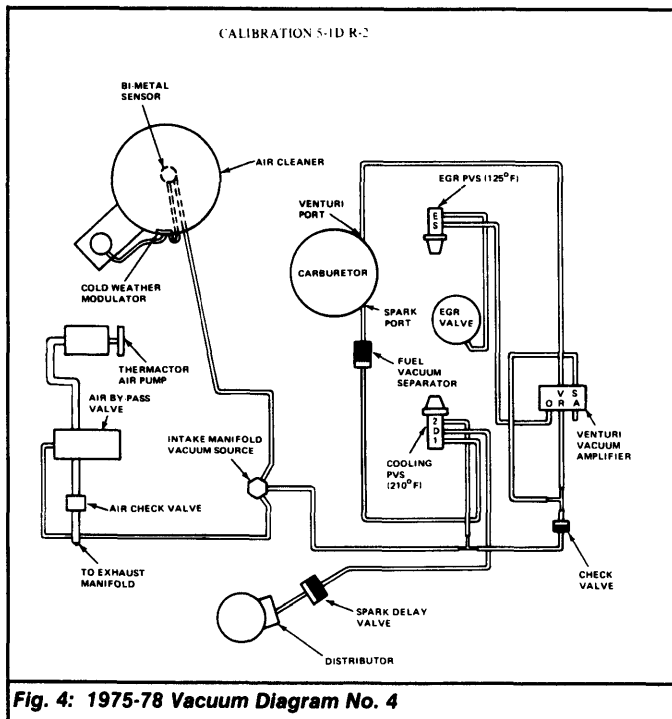
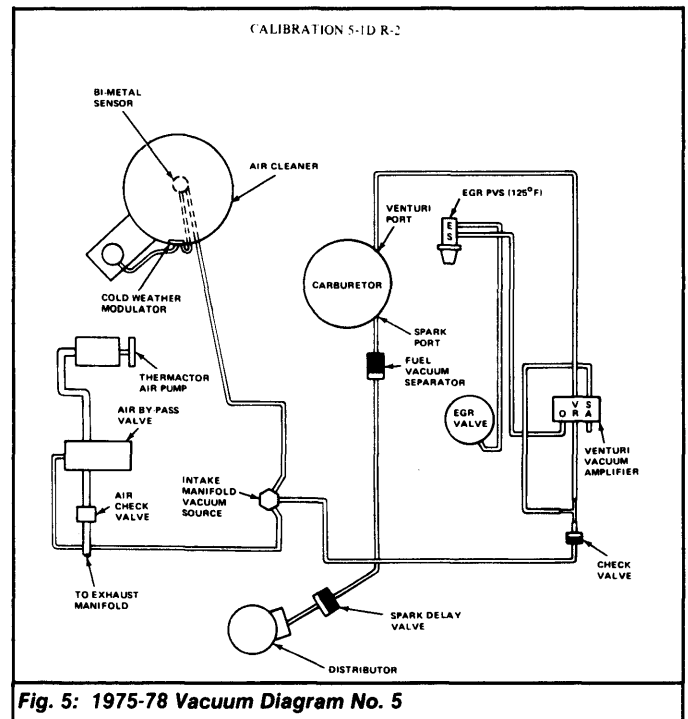
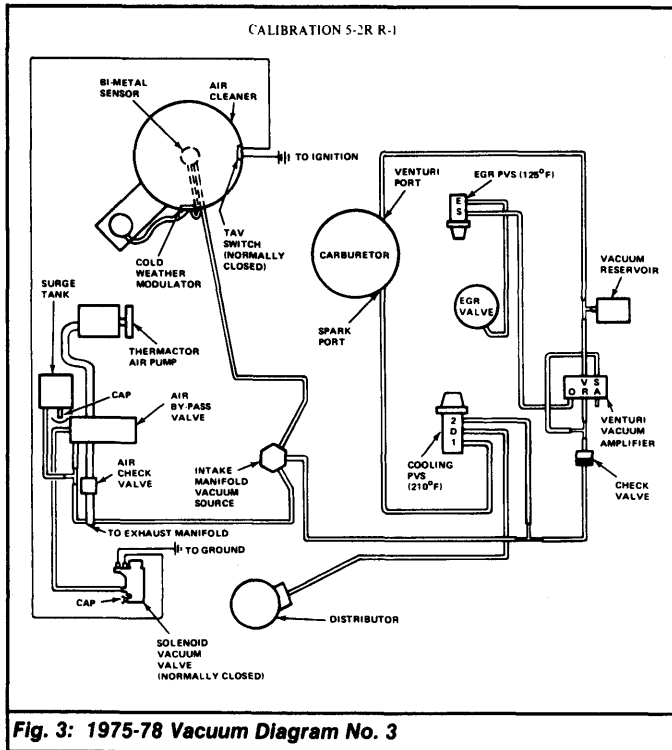

1974-79 EXHAUST EMISSION SYSTEMS Ford Motor Co. Vacuum Diagrams (Cont.)

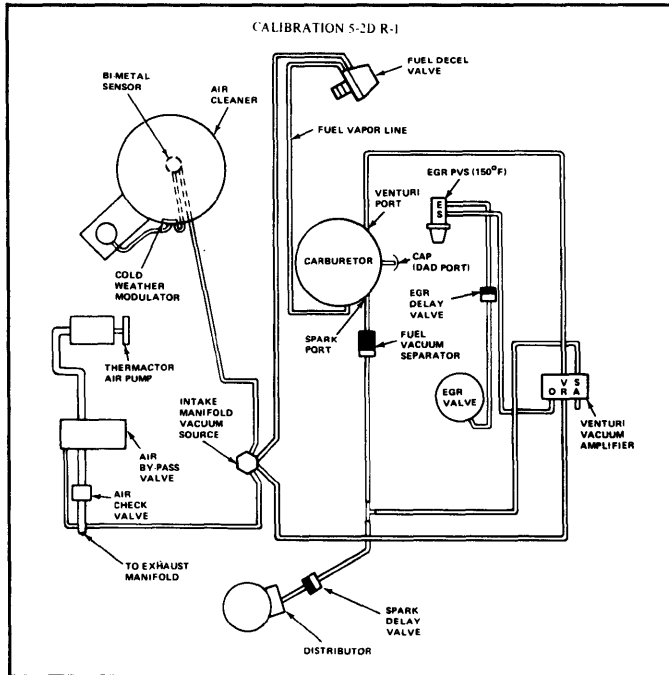

Fig. 7: 1975-78 Vacuum Diagram No. 7

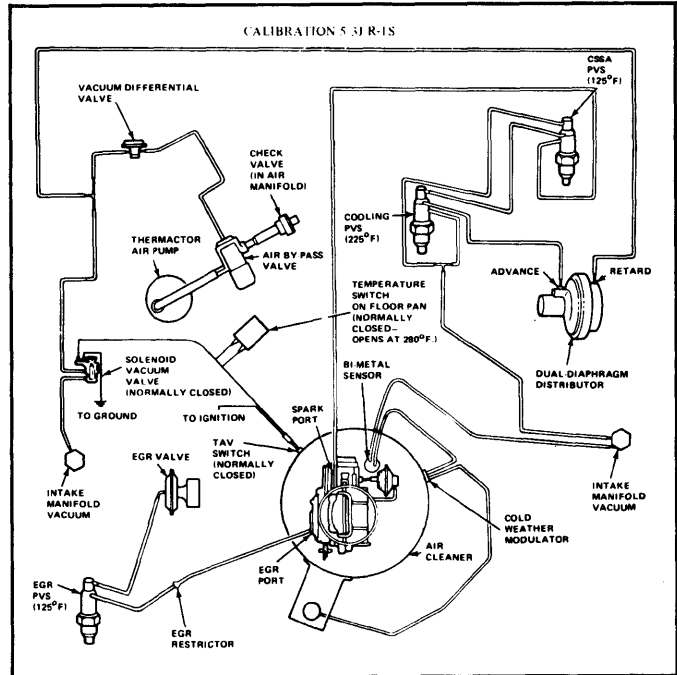

Fig. 9: 1975-78 Vacuum Diagram No. 9

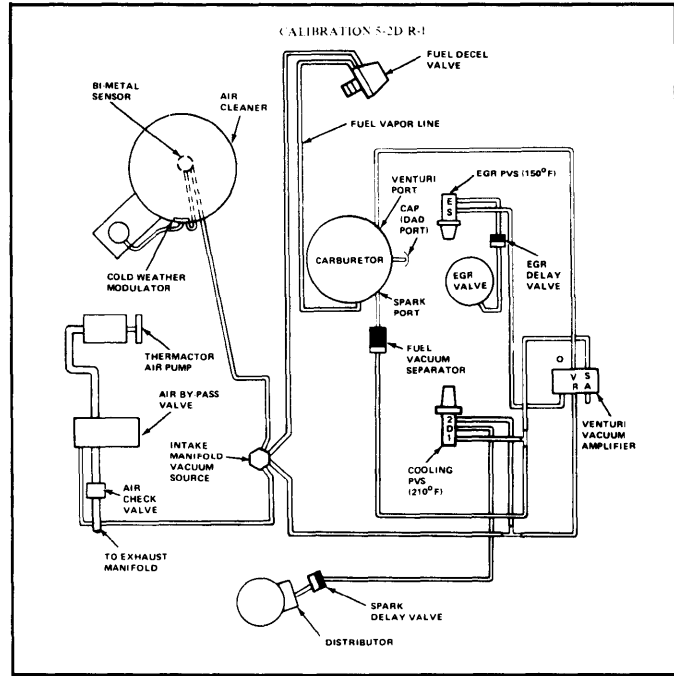

Fig. 8: 1975-78 Vacuum Diagram No. 8

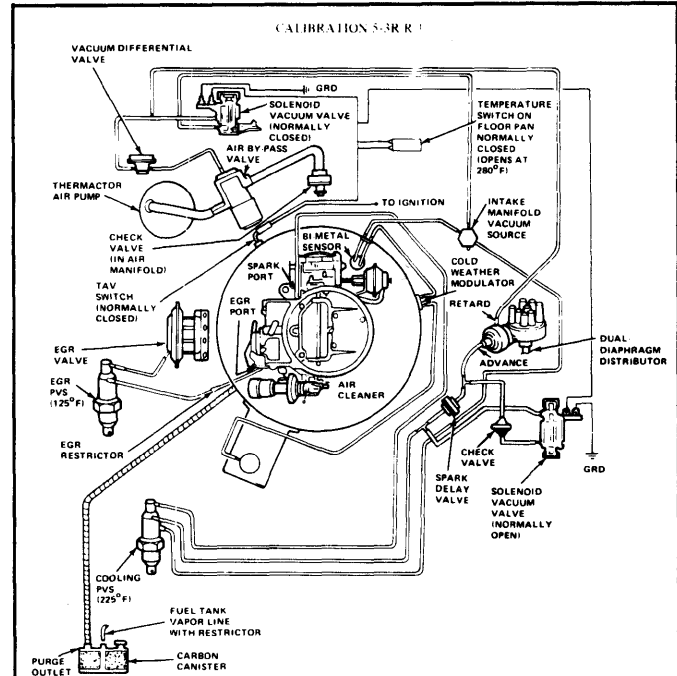

Fig. 10: 1975-78 Vacuum Diagram No. 10

1974-79 EXHAUST EMISSION SYSTEMS Ford Motor Co. Vacuum Diagrams (Cont.)

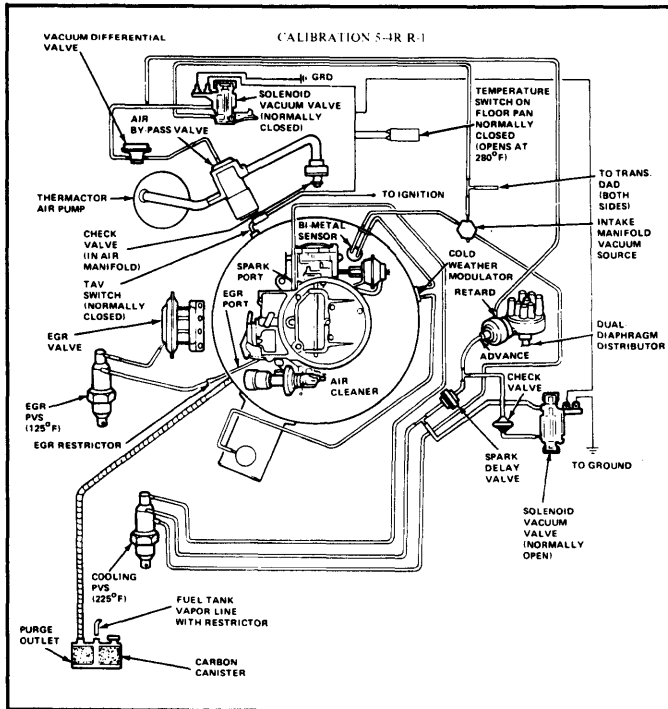

Fig. 11: 1975-78 Vacuum Diagram No. 11

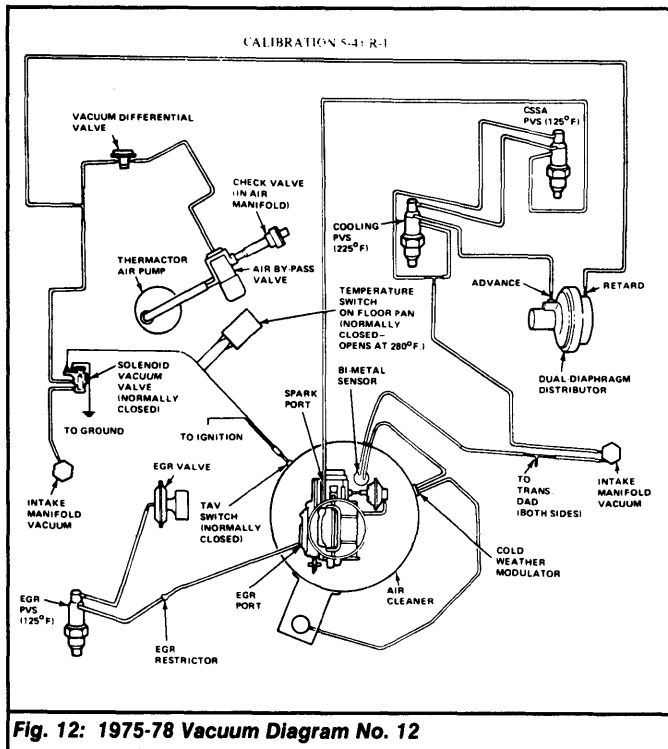

Fig. 12: 1975-78 Vacuum Diagram No. 12

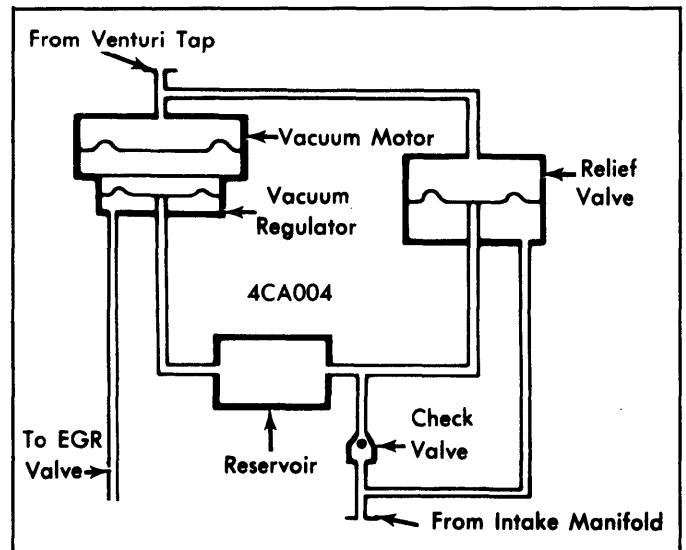

Fig. 13: 1974 EGR/Vacuum Amplifier System

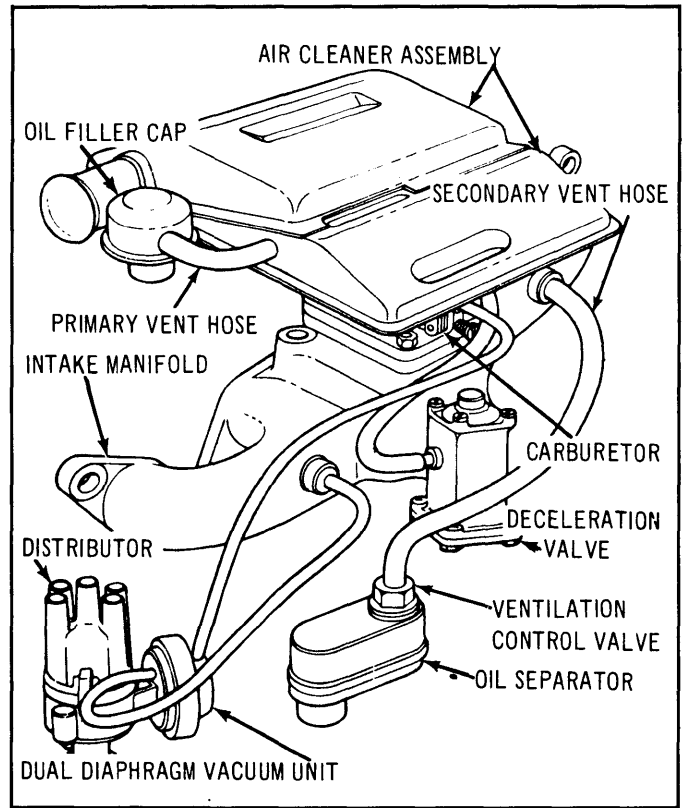

Fig. 14: 1974-76 Positive Crankcase Ventilation System

1974-79 EXHAUST EMISSION SYSTEMS

Ford Motor Co. Vacuum Diagrams (Cont.)

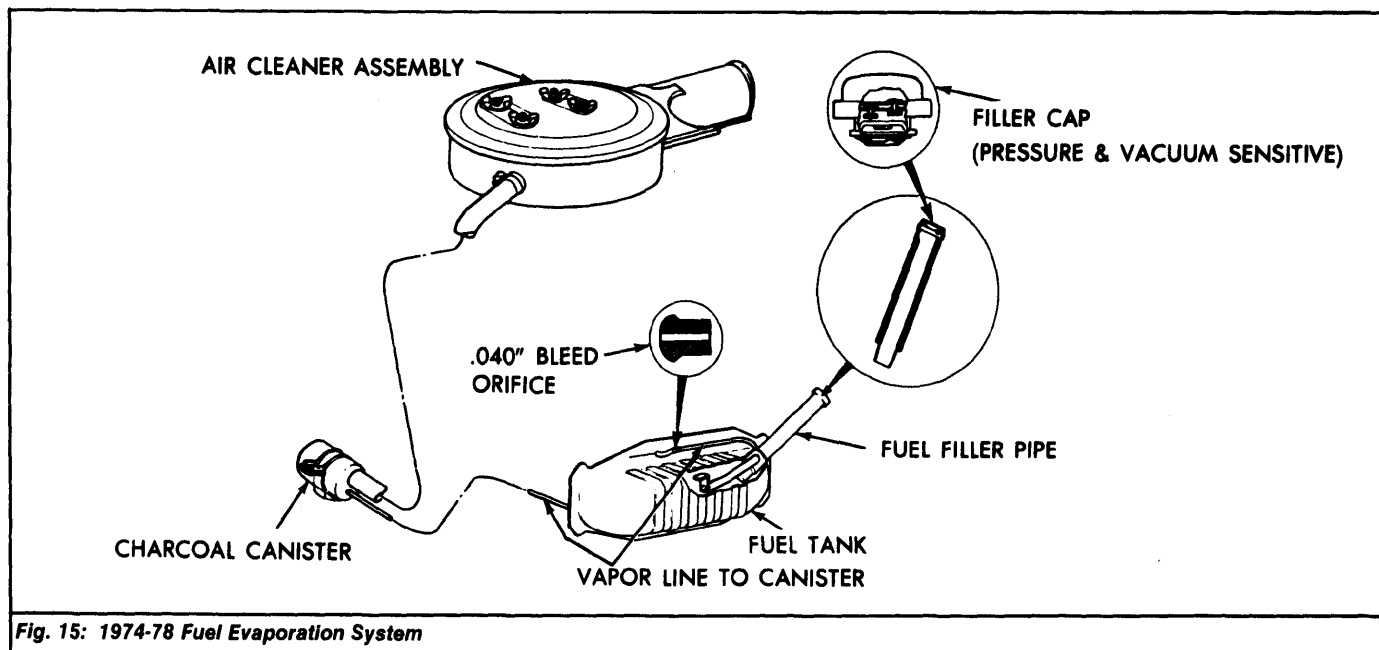

Fig. 15: 1974-78 Fuel Evaporation System

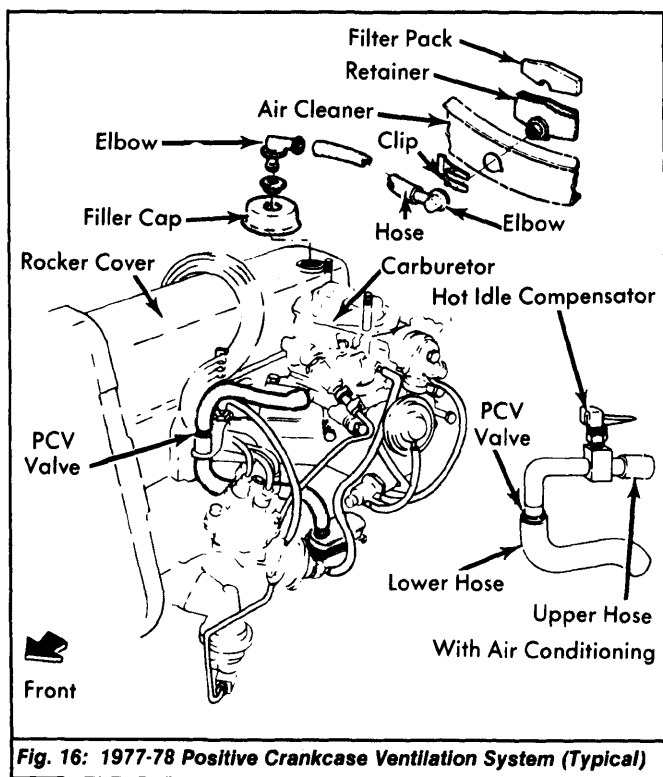

Fig. 16: 1977-78 Positive Crankcase Ventilation System (Typical)