

# 1974-79 EXHAUST EMISSION SYSTEMS

## Ford Motor Co. Spark Delay Valve System

### 1975-78 Capri, Capri II

#### DESCRIPTION

The Spark Delay Valve (SDV) system, used on most engines, aids in the control of exhaust emission by delaying vacuum spark advance. The bidirectional valve controls vacuum flow by means of an internal sintered metal disc and check valve combination.

#### OPERATION

Purpose of the valve is to delay vacuum spark advance during periods of acceleration and still permit immediate spark retard on deceleration. The length of delay will depend on engine application. Several different valves are used and can be identified by a color code. See SDV COLOR CODE/SPECIFICATIONS table.

#### TROUBLE SHOOTING

If valve is defective or installed backwards, engine will idle roughly, ping, and increase fuel consumption. When blowing air through valve by mouth, air will appear to flow in one direction. This should not be misinterpreted as direction of vacuum flow.

**NOTE:** It is very important that BLACK or inlet side of Spark Delay Valve and by-pass check valve be connected to vacuum line leading to carburetor.

#### TESTING

##### SPARK DELAY VALVE

**Single Delay System** - 1) Set vacuum test gauge to 10 in. Hg. Connect Black side of spark delay valve to vacuum source. Connect a 24" section of vacuum hose to gauge and to colored side of delay valve. Apply vacuum and observe time in seconds for gauge to reach 8 in. Hg with a 10 in. Hg vacuum source.

2) To inspect delay valve for excessive restriction, minimum and maximum time for valve to reach 8 in. Hg should be as specified. See SDV COLOR CODE/SPECIFICATIONS table. If valve fails tests, it should be replaced.

**Dual Delay System** - 1) Use an external vacuum source of 10 in. Hg. Connect a 24" section of vacuum hose to gauge and to distributor port of delay valve. Connect Black side of delay valve and "CARB" port of delay valve to vacuum source.

2) Clamp vacuum hose from "CARB" port and apply 10 in. Hg to Black side of delay valve. Gauge should read 8 in. Hg in time specified. See SDV COLOR CODE/SPECIFICATIONS table.

3) Clamp distributor port, unclamp "CARB" port and apply vacuum of 10 in. Hg to "CARB" port. Gauge should read 8 in. Hg in time specified. See SDV COLOR CODE/SPECIFICATIONS table. If valve fails tests, it should be replaced.

#### SDV COLOR CODE/SPECIFICATIONS

Valve Color	Seconds (Min.)	Seconds (Max.)
White & Brown	2	5
White & Green	9	20
Black & Grey	1	4
Black & Brown	2	5
Black & White	4	12
Black & Yellow	5.8	14
Black & Blue	7	16
Black & Green	9	20
Black & Orange	13	24
Black & Red	15	28

#### CHECK VALVE

With vacuum supply connected to Black side of check valve and vacuum gauge on opposite side, gauge should read vacuum instantly. Reverse connections. Zero vacuum should be indicated. If valve fails either test, it must be replaced.

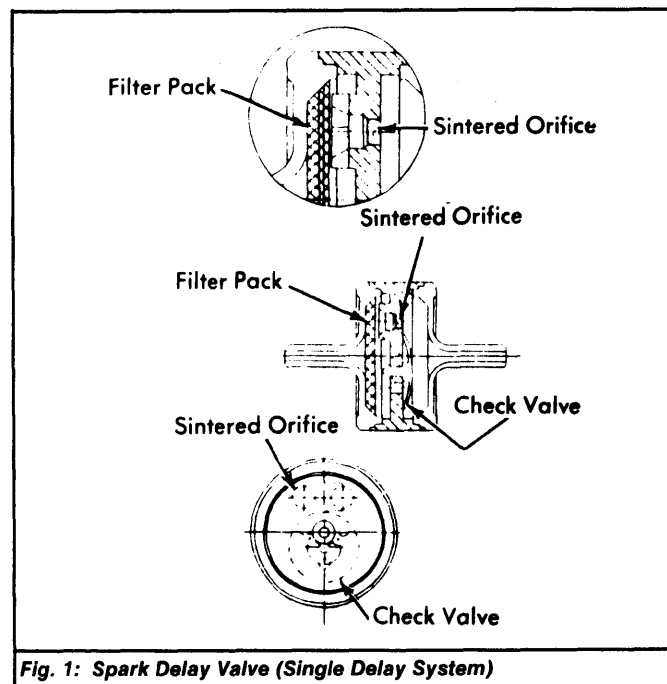

Fig. 1: Spark Delay Valve (Single Delay System)