

1974-79 EXHAUST EMISSION SYSTEMS Chrysler Corp. Vacuum Diagrams

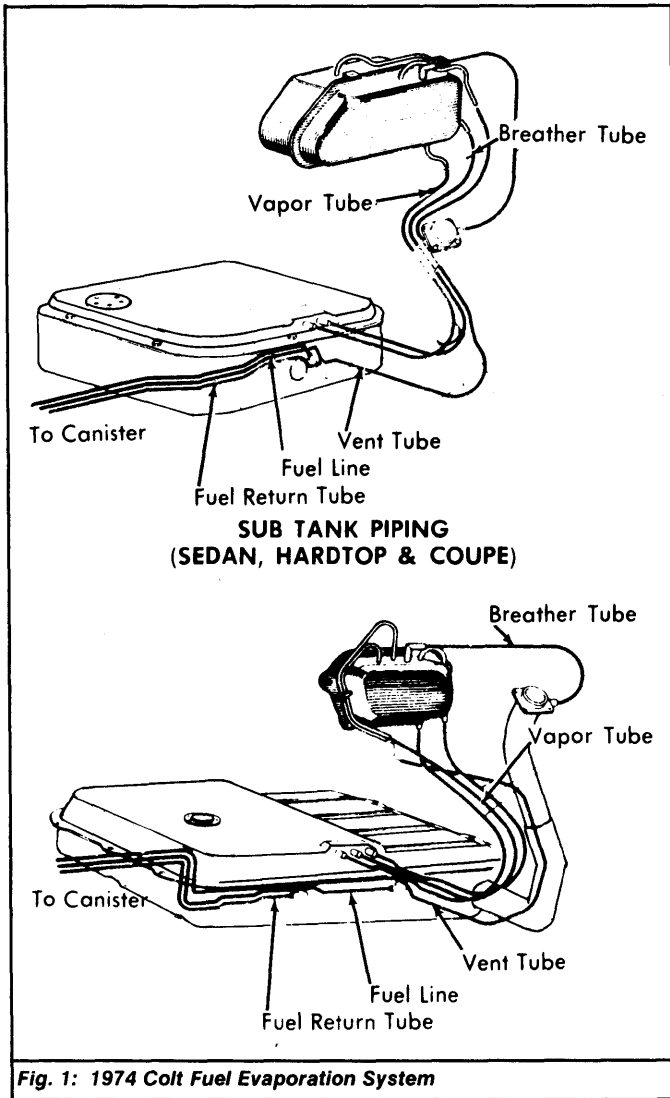

Fig. 1: 1974 Colt Fuel Evaporation System

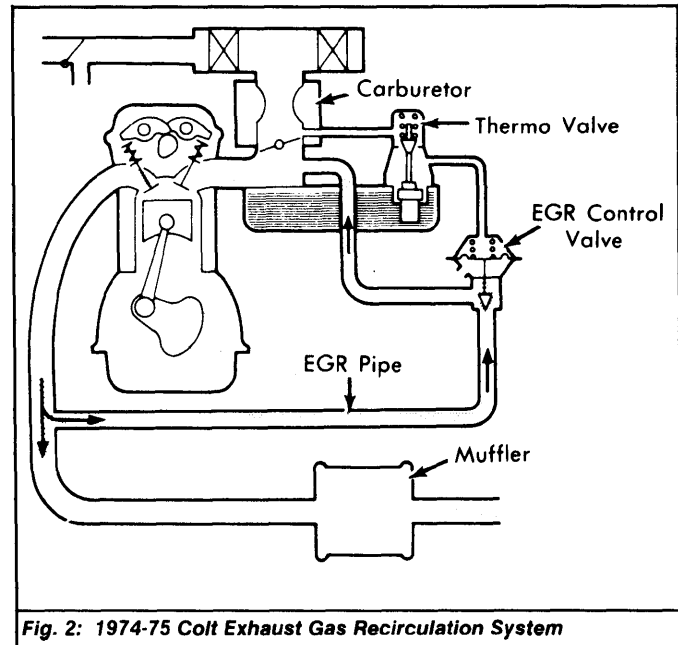

Fig. 2: 1974-75 Colt Exhaust Gas Recirculation System

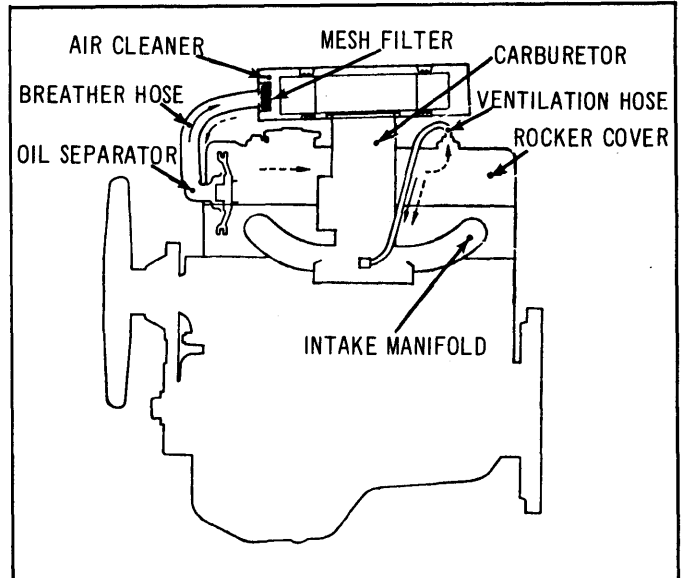

Fig. 3: 1974-75 Colt Positive Crankcase Ventilation System

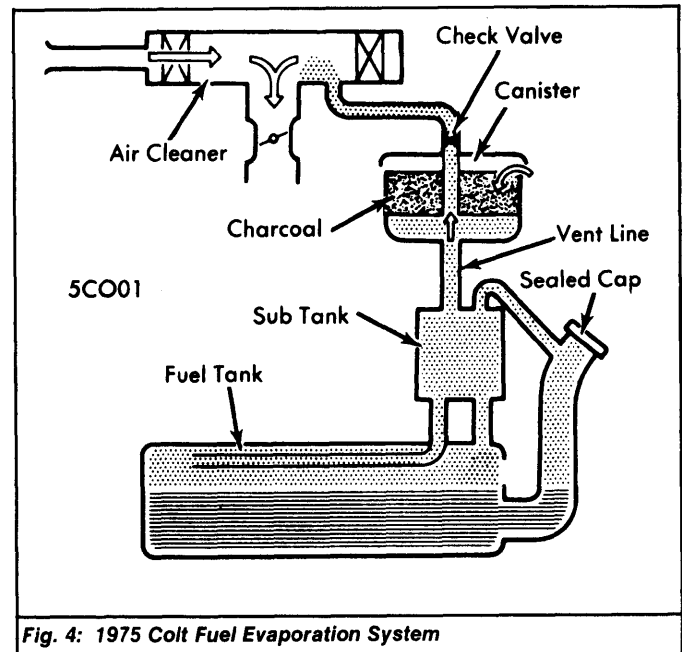

Fig. 4: 1975 Colt Fuel Evaporation System

1974-79 EXHAUST EMISSION SYSTEMS Chrysler Corp. Vacuum Diagrams (Cont.)

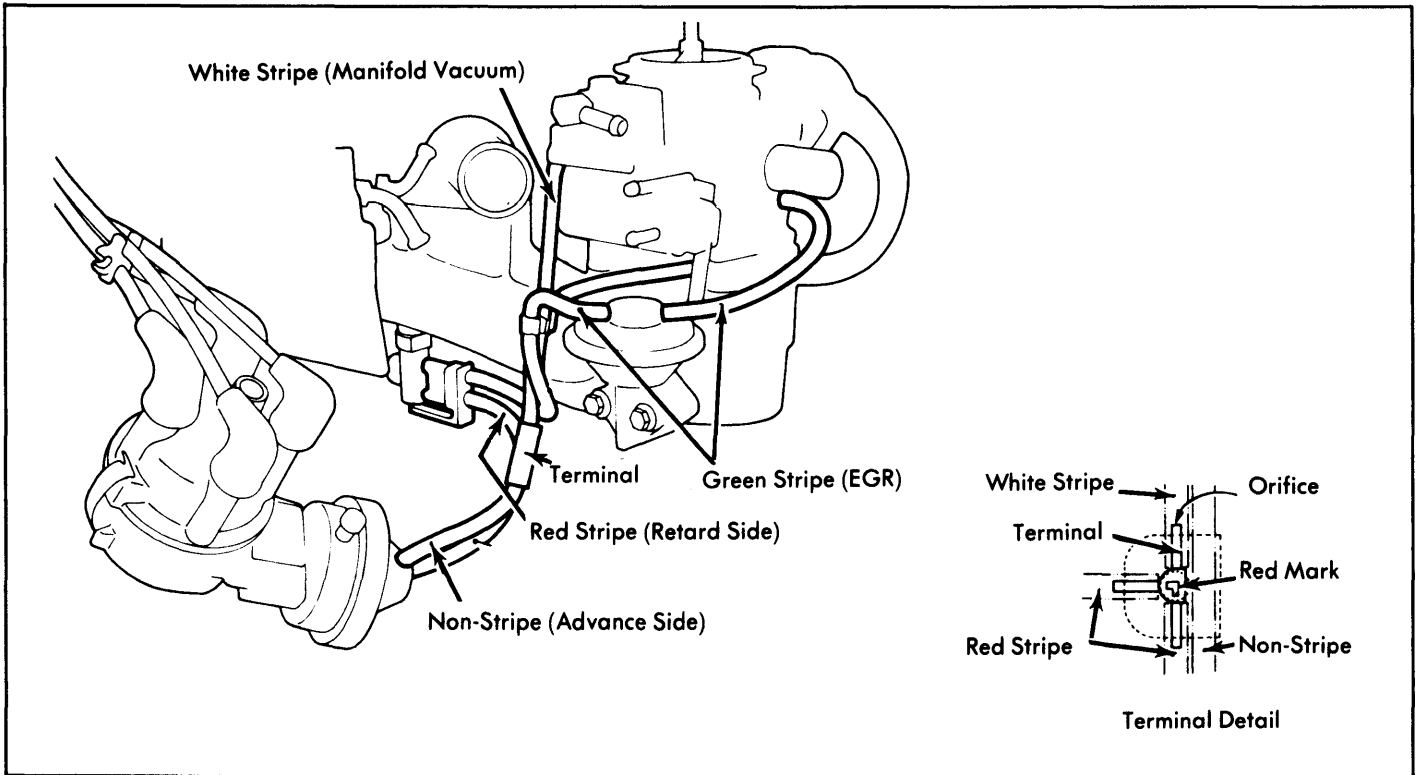

Fig. 5: 1976 Arrow & Colt (1600cc Engine) Exhaust Emission System

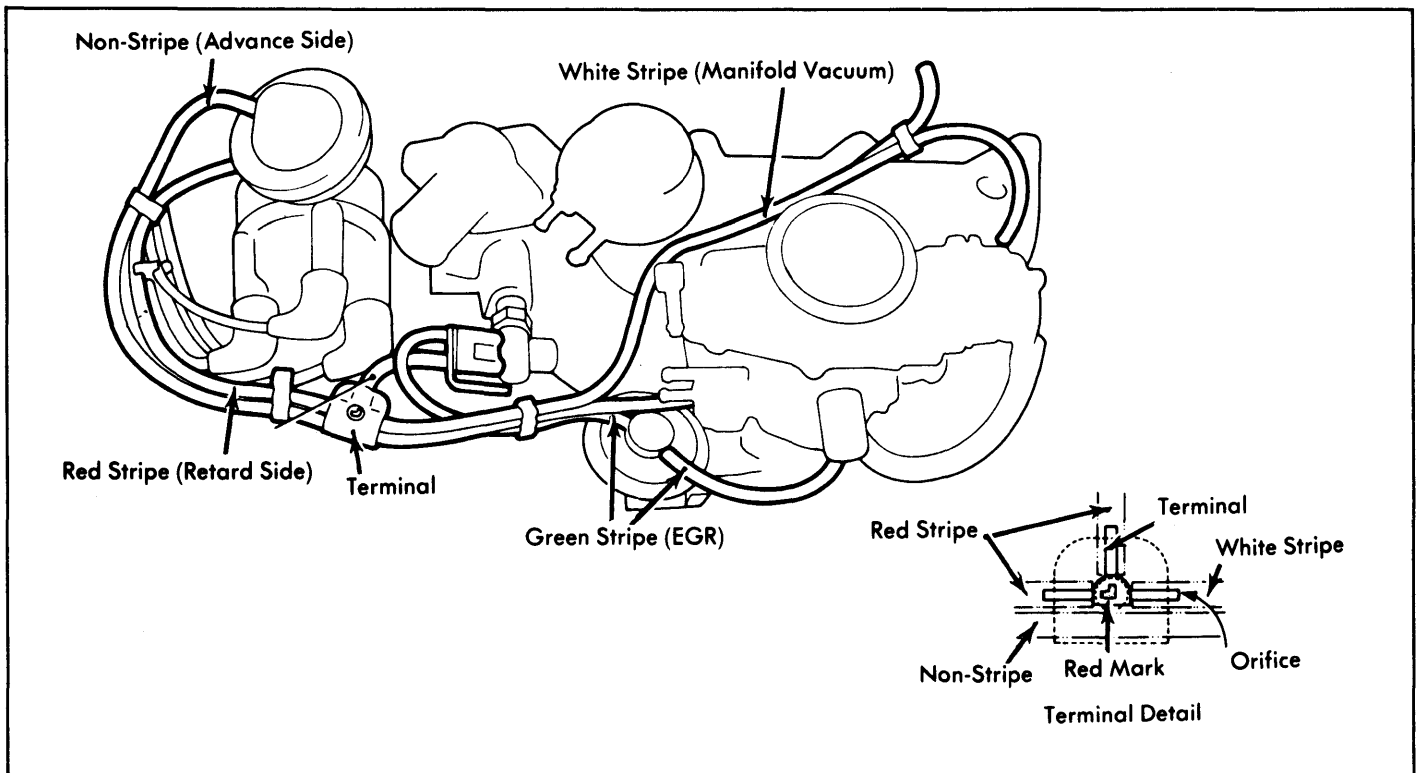

Fig. 6: 1976 Arrow (2000cc Engine) Exhaust Emission System

1974-79 EXHAUST EMISSION SYSTEMS Chrysler Corp. Vacuum Diagrams (Cont.)

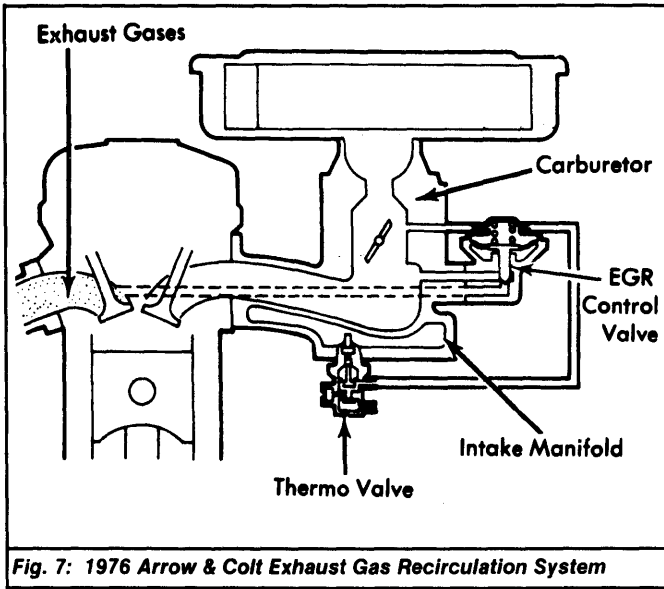

Fig. 7: 1976 Arrow & Colt Exhaust Gas Recirculation System

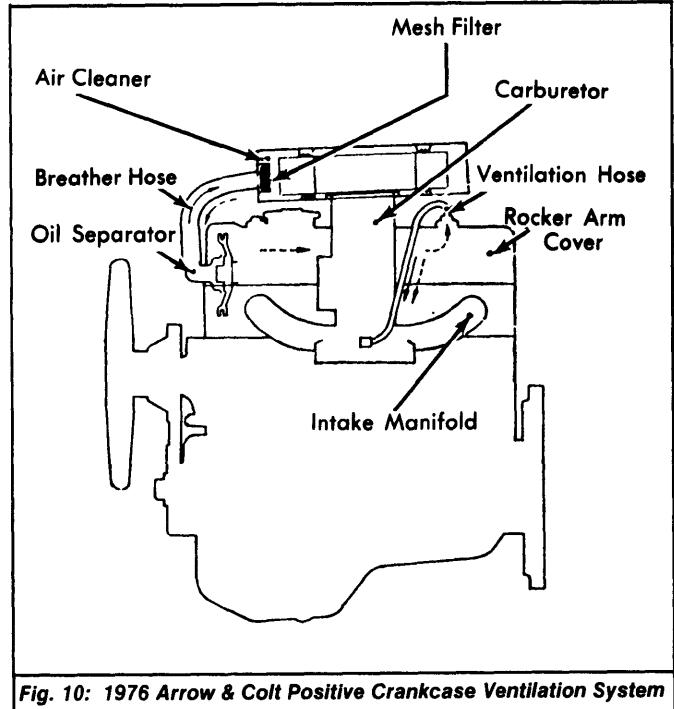

Fig. 10: 1976 Arrow & Colt Positive Crankcase Ventilation System

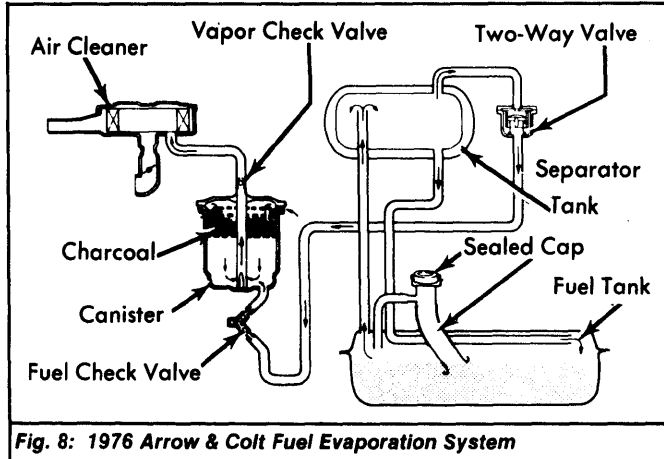

Fig. 8: 1976 Arrow & Colt Fuel Evaporation System

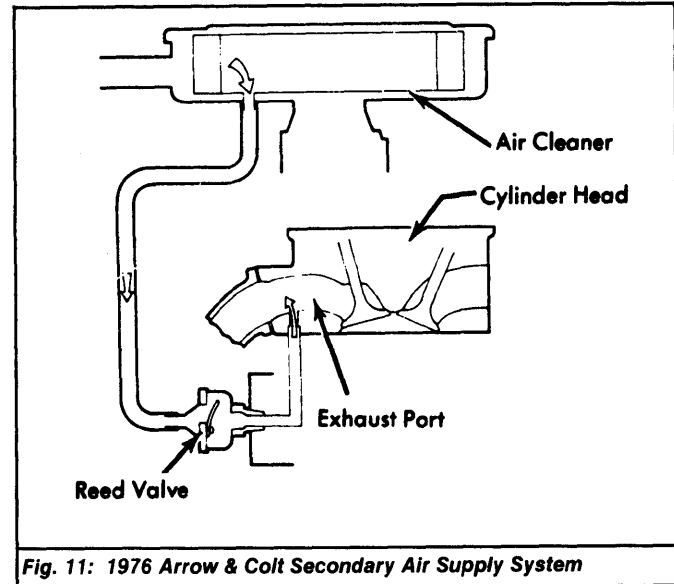

Fig. 11: 1976 Arrow & Colt Secondary Air Supply System

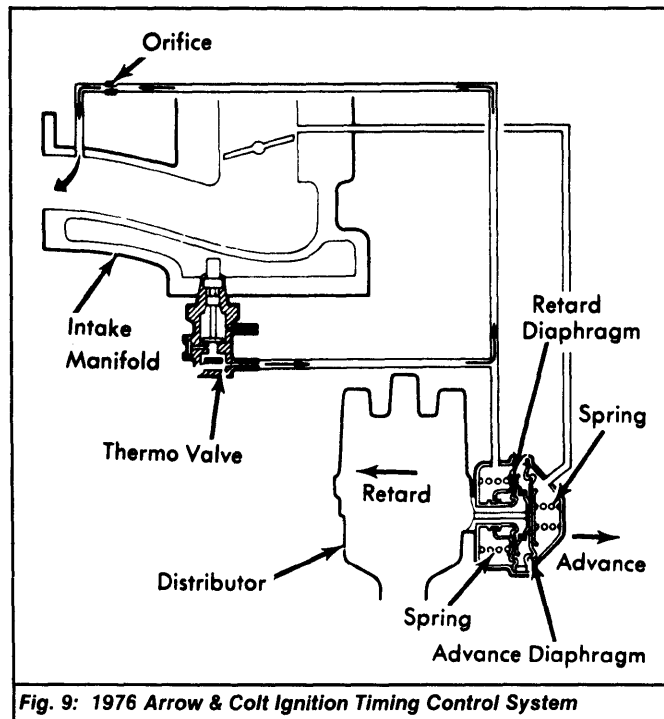

Fig. 9: 1976 Arrow & Colt Ignition Timing Control System

1974-79 EXHAUST EMISSION SYSTEMS Chrysler Corp. Vacuum Diagrams (Cont.)

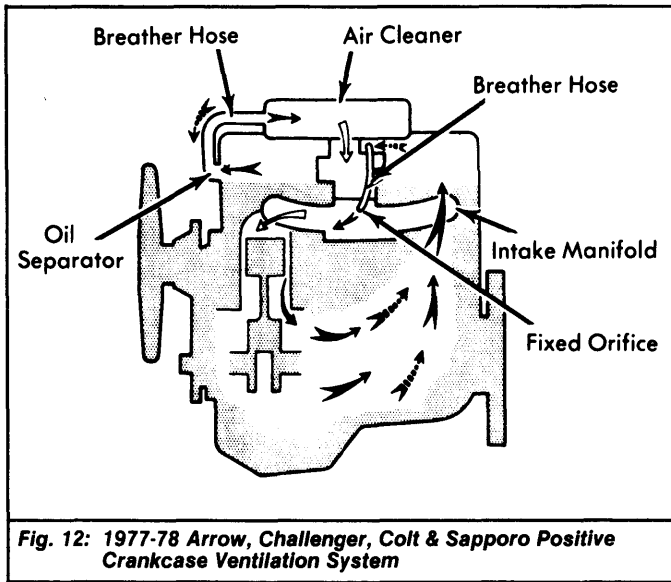

Fig. 12: 1977-78 Arrow, Challenger, Colt & Sapporo Positive Crankcase Ventilation System

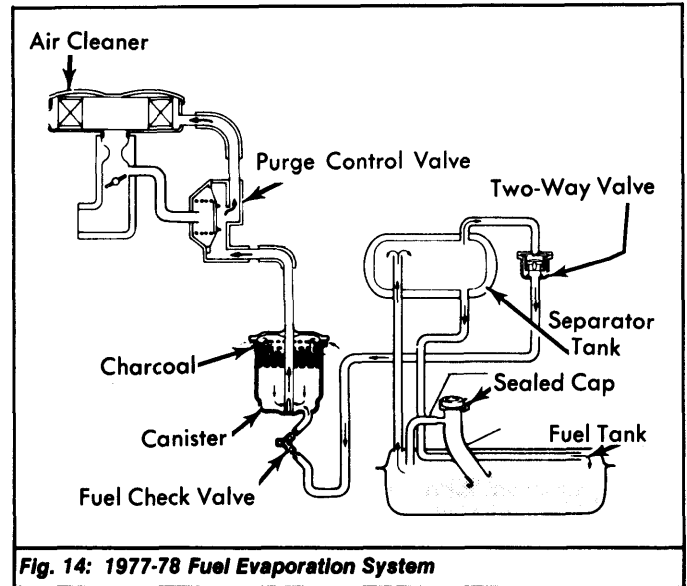

Fig. 14: 1977-78 Fuel Evaporation System

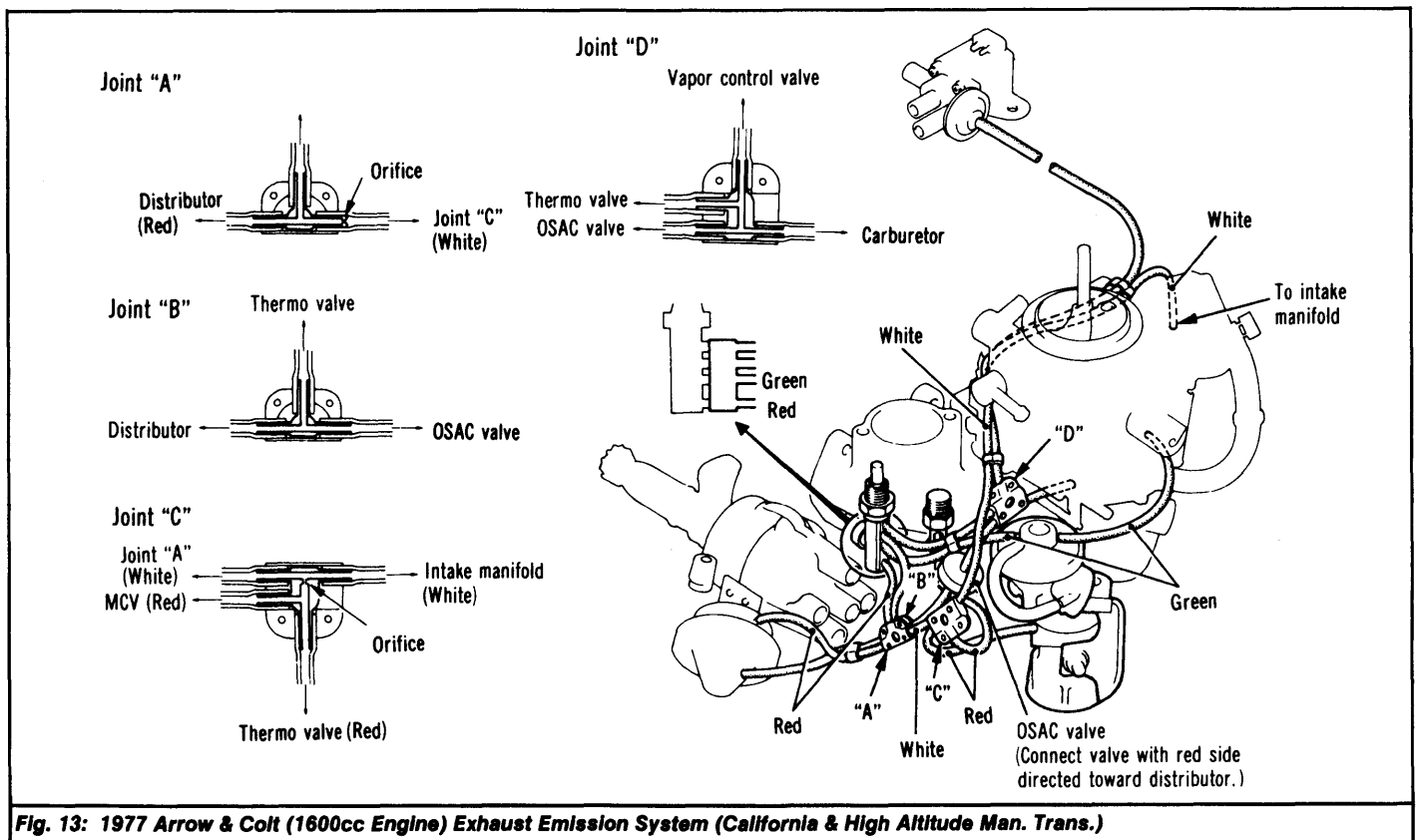

Fig. 13: 1977 Arrow & Colt (1600cc Engine) Exhaust Emission System (California & High Altitude Man. Trans.)

1974-79 EXHAUST EMISSION SYSTEMS Chrysler Corp. Vacuum Diagrams (Cont.)

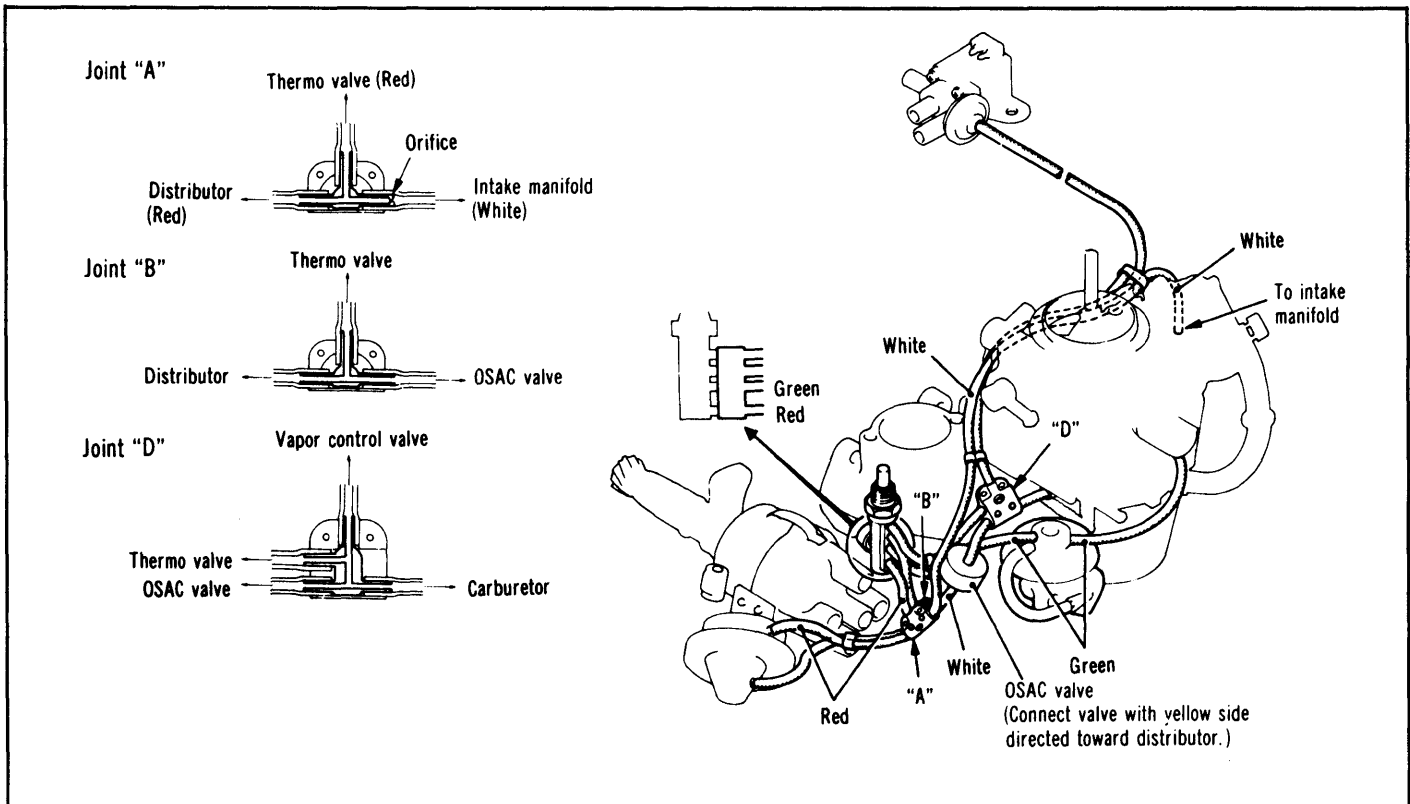

Fig. 15: 1977 Arrow & Colt (1600cc Engine) Exhaust Emission System (California & High Altitude Auto. Trans.)

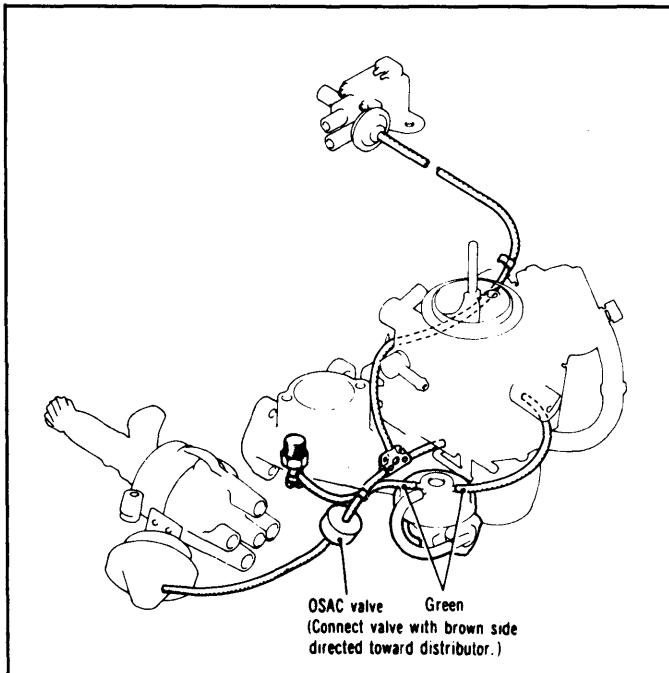

Fig. 16: 1977 Arrow & Colt (1600cc Engine) Exhaust Emission System (Federal Man. Trans.)

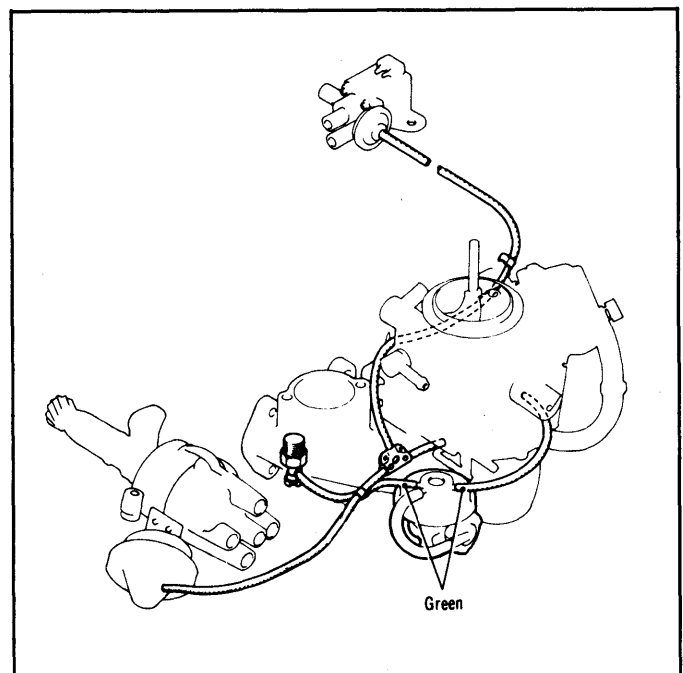

Fig. 17: 1977 Arrow & Colt (1600cc Engine) Exhaust Emission System (Federal Auto. Trans.)

1974-79 EXHAUST EMISSION SYSTEMS Chrysler Corp. Vacuum Diagrams (Cont.)

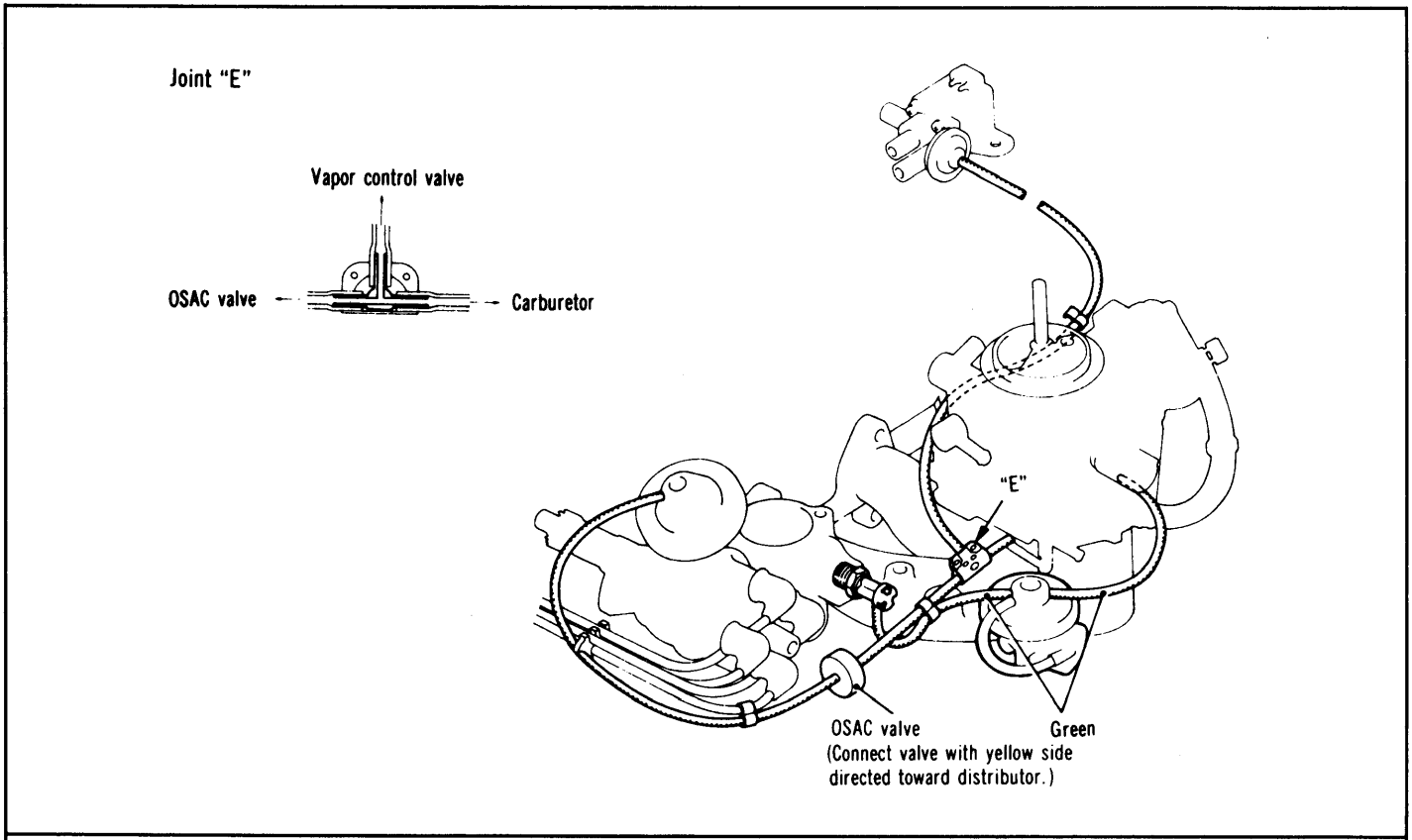

Fig. 18: 1977 Arrow & Colt (2000cc Engine) Exhaust Emission System (Federal)

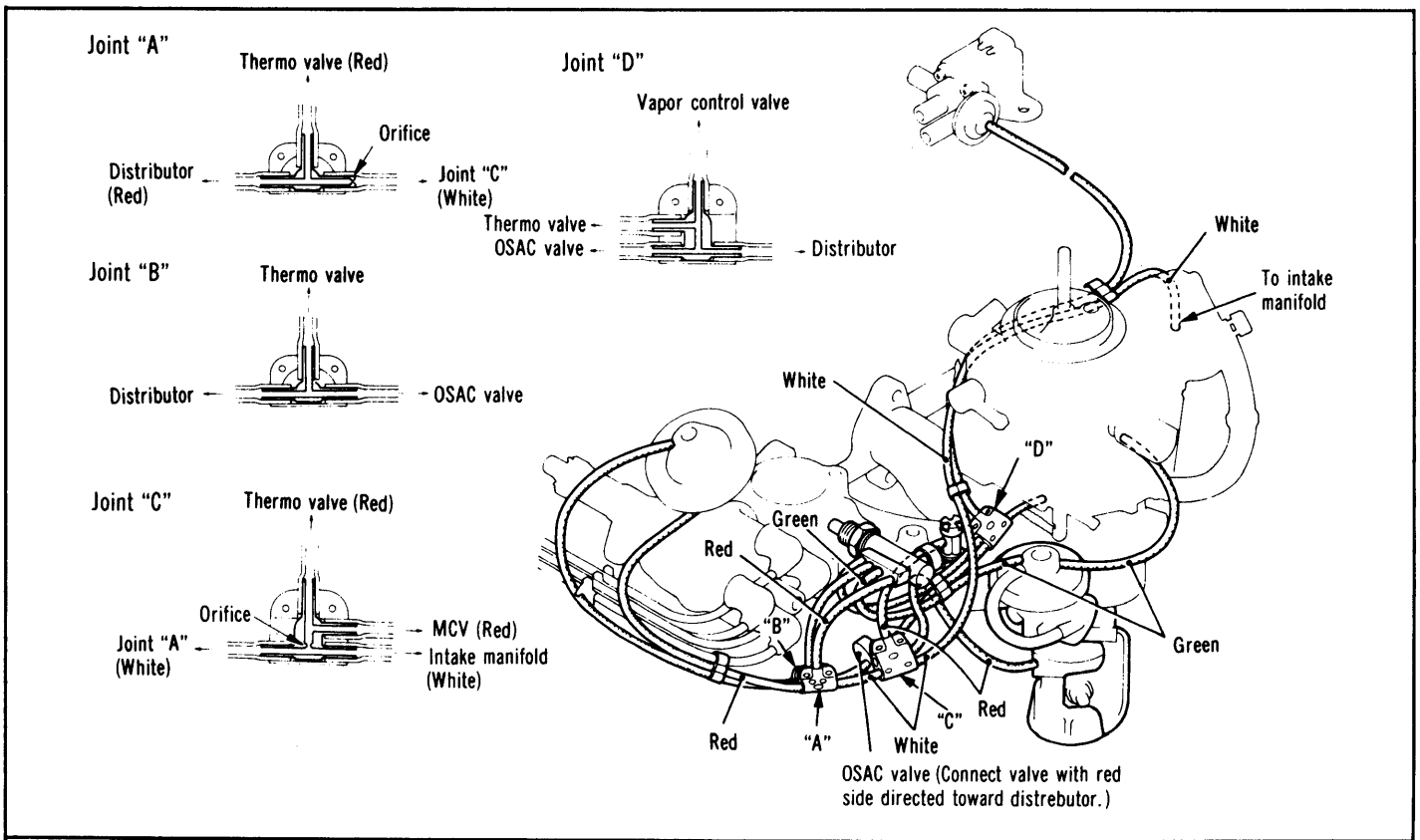

Fig. 19: 1977 Arrow & Colt (2000cc Engine) Exhaust Emission System (California Man. Trans.)

1974-79 EXHAUST EMISSION SYSTEMS Chrysler Corp. Vacuum Diagrams (Cont.)

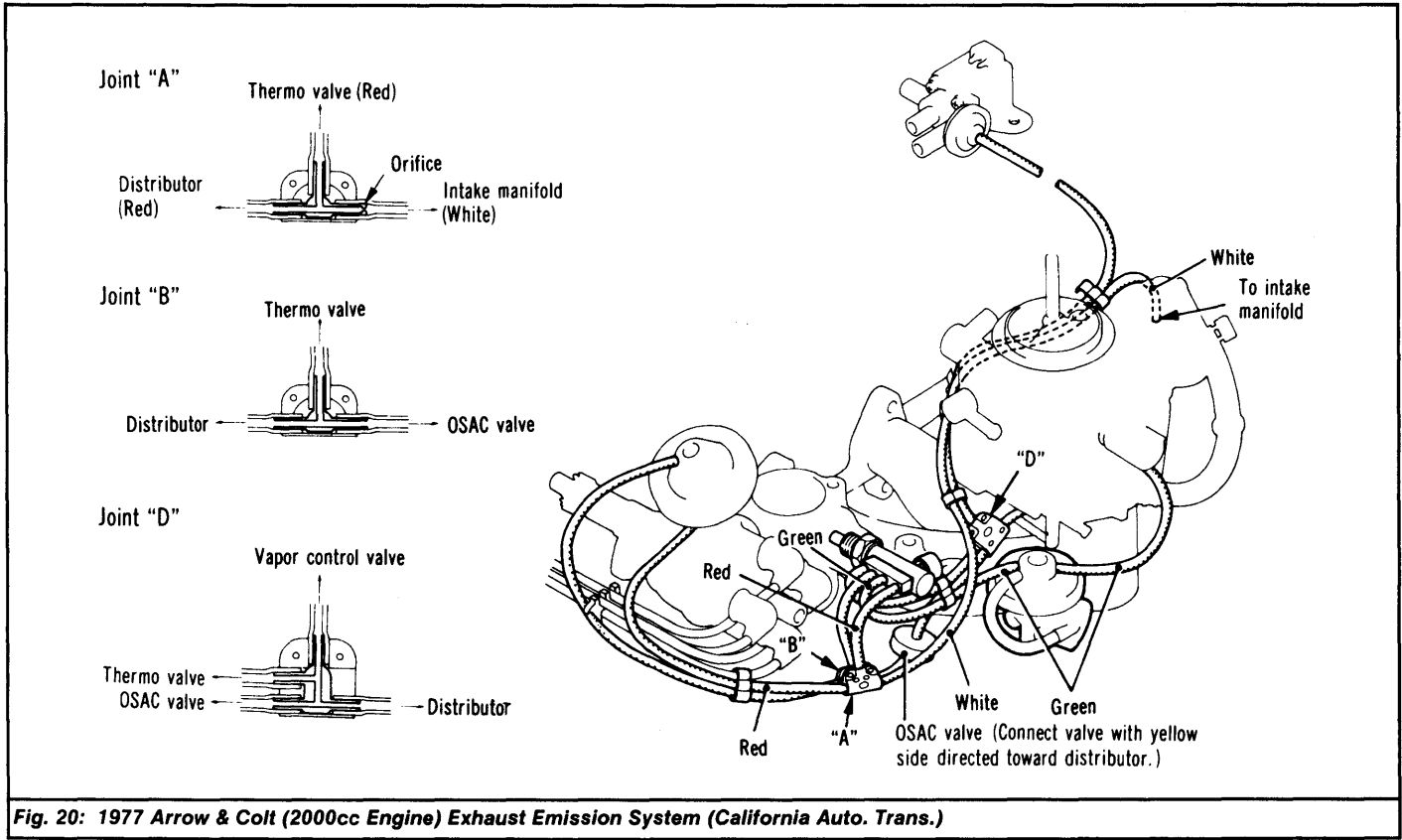

Fig. 20: 1977 Arrow & Colt (2000cc Engine) Exhaust Emission System (California Auto. Trans.)

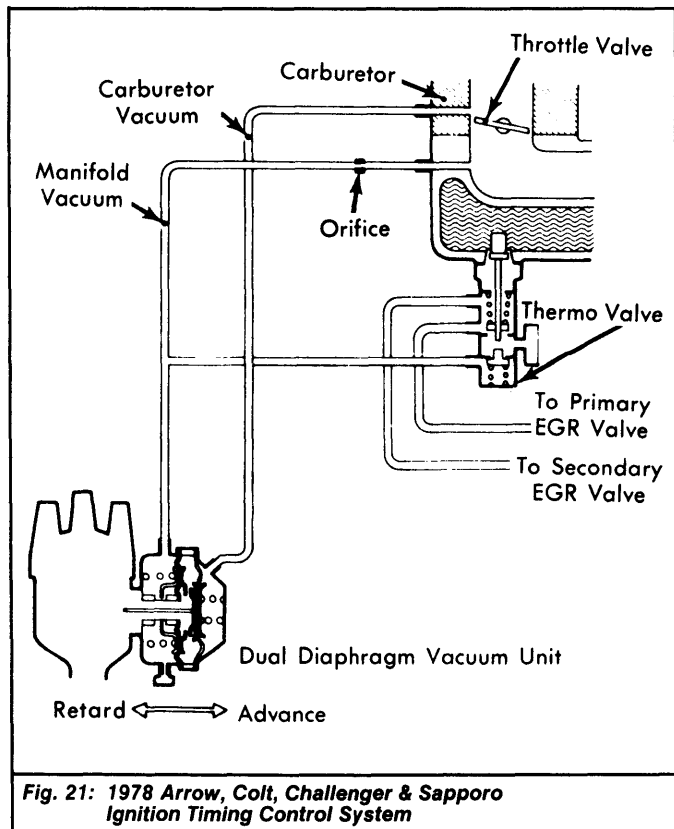

Fig. 21: 1978 Arrow, Colt, Challenger & Sapporo Ignition Timing Control System