

1974-79 EXHAUST EMISSION SYSTEMS

Chrysler Corp. Jet Air System

3-73

1978-79 Models

DESCRIPTION

The jet air system uses an additional valve in the top of each combustion chamber to inject a high velocity stream of air at small throttle openings. On the intake stroke, air rushing out of the jet valve opening scavenges gases from around the spark plug and produces a strong swirl in the combustion chamber. This promotes high combustion efficiency and results in lower exhaust emissions. The jet valve is operated by an extension on the intake valve rocker arm. The valve assembly consists of a jet valve, jet body and spring. The assembly is screwed into the jet piece, which is press-fitted in the cylinder head with the jet opening toward spark plug.

OPERATION

Air flows to the jet valve through two intake openings near the carburetor throttle valve, a passage in the intake manifold and a passage in the cylinder head. The intake stroke pulls air into the combustion chamber through the intake valve port and the jet valve opening. When the throttle valve opening is small, a large pressure difference is produced between the jet valve opening and the jet intake opening as the piston goes down. This causes jet air to flow into the combustion chamber at a much higher speed than it does at large throttle openings. Because the jet valve opening points directly at the spark plug, the air stream scavenges gases accumulated in that area. It also produces a swirling action in the combustion chamber which continues throughout the compression stroke. This results in a longer burn period after ignition.

ADJUSTMENTS

JET VALVE

1) Before performing jet valve adjustment, cylinder head bolts must be retightened (cold) to 65-72 ft. lbs. (88-98 N.m). After engine is at

normal operating temperature, stop engine, remove rocker cover, and position appropriate piston at TDC.

2) Back off intake valve side adjusting screw 2 or more turns. Jet valve clearance should be adjusted with intake valve adjusting screw fully loosened. Loosen lock nut on jet valve adjusting screw.

3) Back off jet valve adjusting screw (counterclockwise) and place .006" (0.15 mm) feeler gauge between top end of jet valve stem and bottom end of adjusting screw. See Fig. 2.

4) Turn down adjusting screw (clockwise) until proper clearance is obtained. Hold adjusting screw and tighten lock nut. Recheck clearance. Adjust intake valve clearance to .006" (.15 mm). Repeat adjustment at each cylinder.

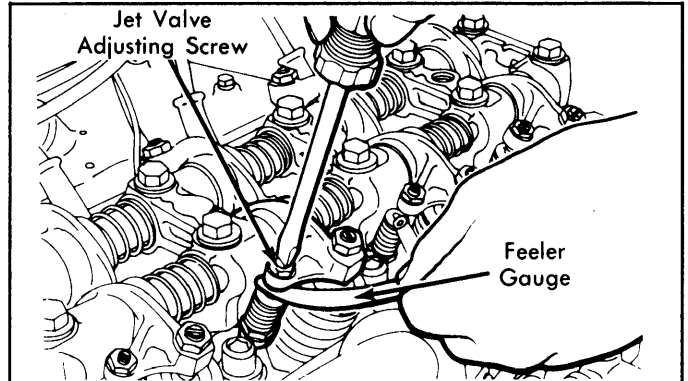

Fig. 2: Adjusting Jet Valve Clearance

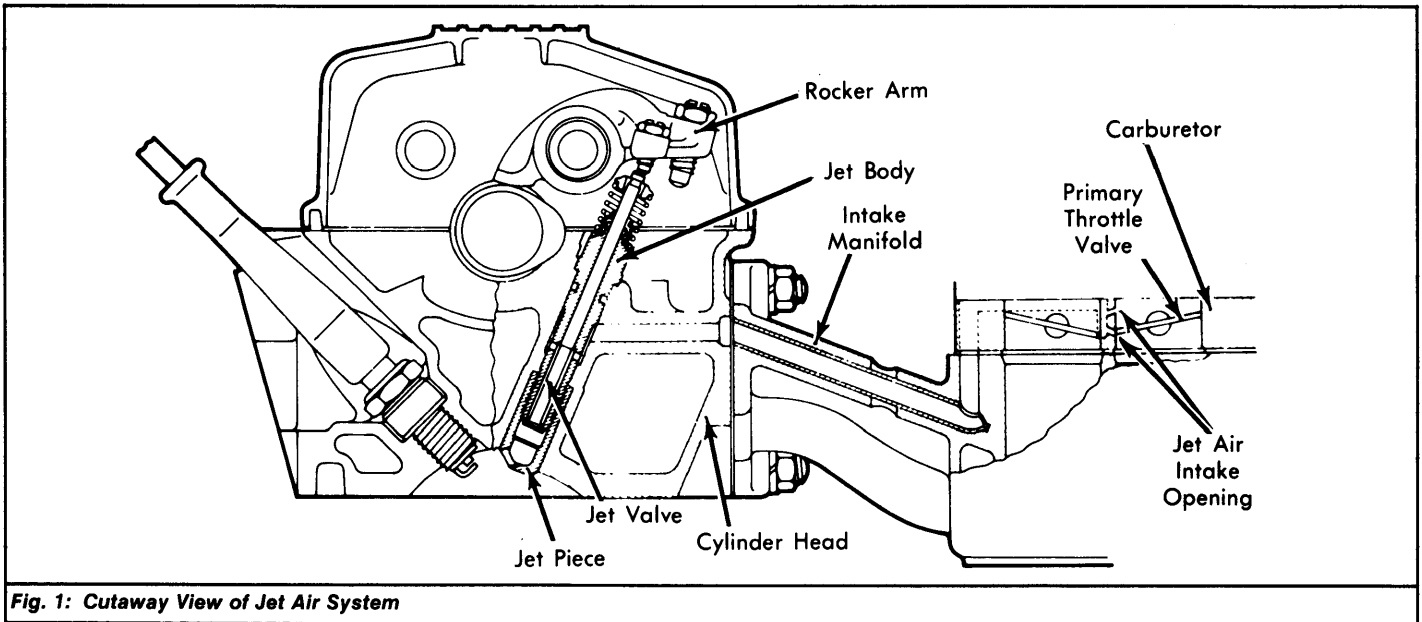

Fig. 1: Cutaway View of Jet Air System