

# 1974-79 EXHAUST EMISSION SYSTEMS

## BMW Vacuum Diagrams

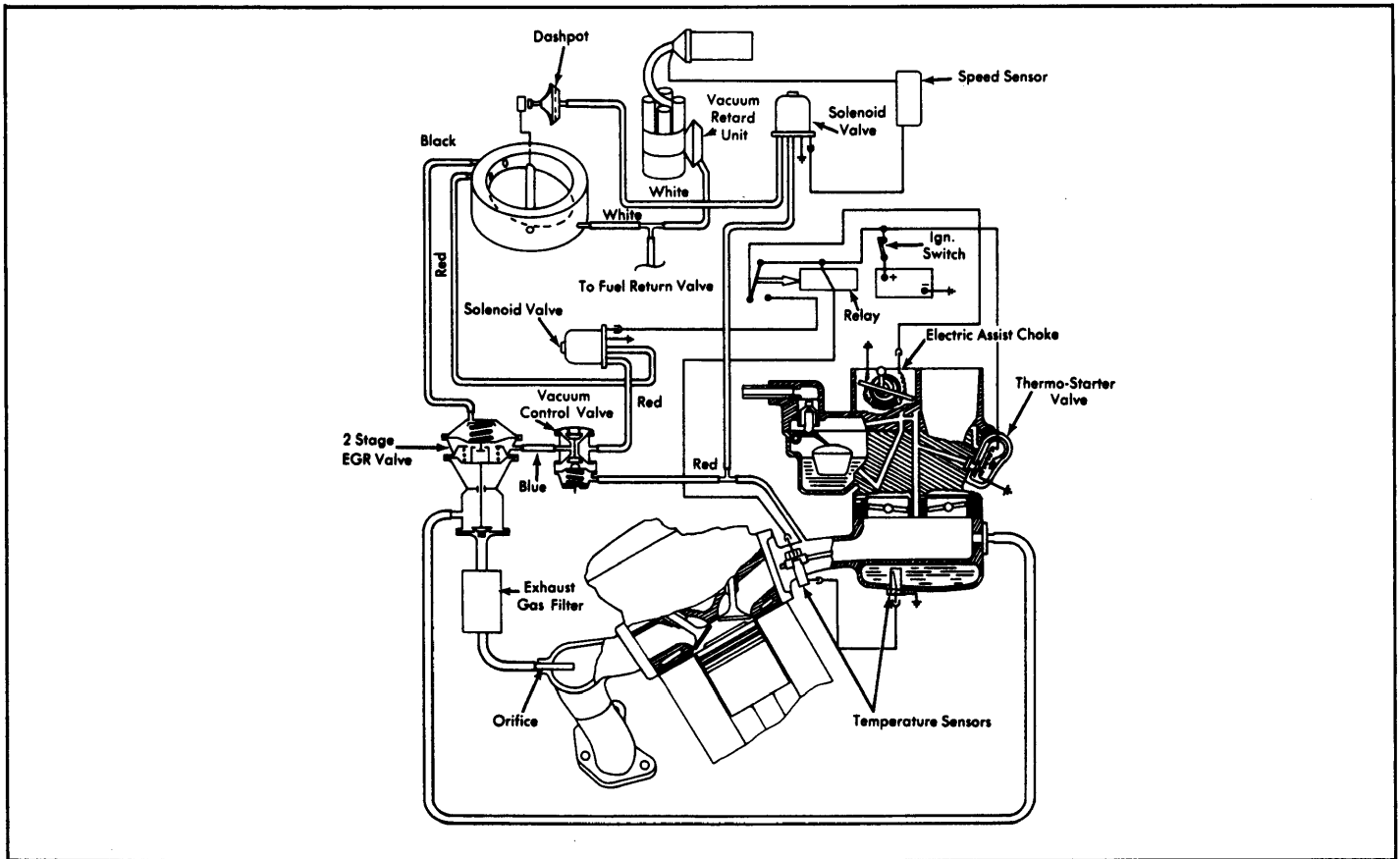

**Fig. 1: 1974 2002 Exhaust Emission System**

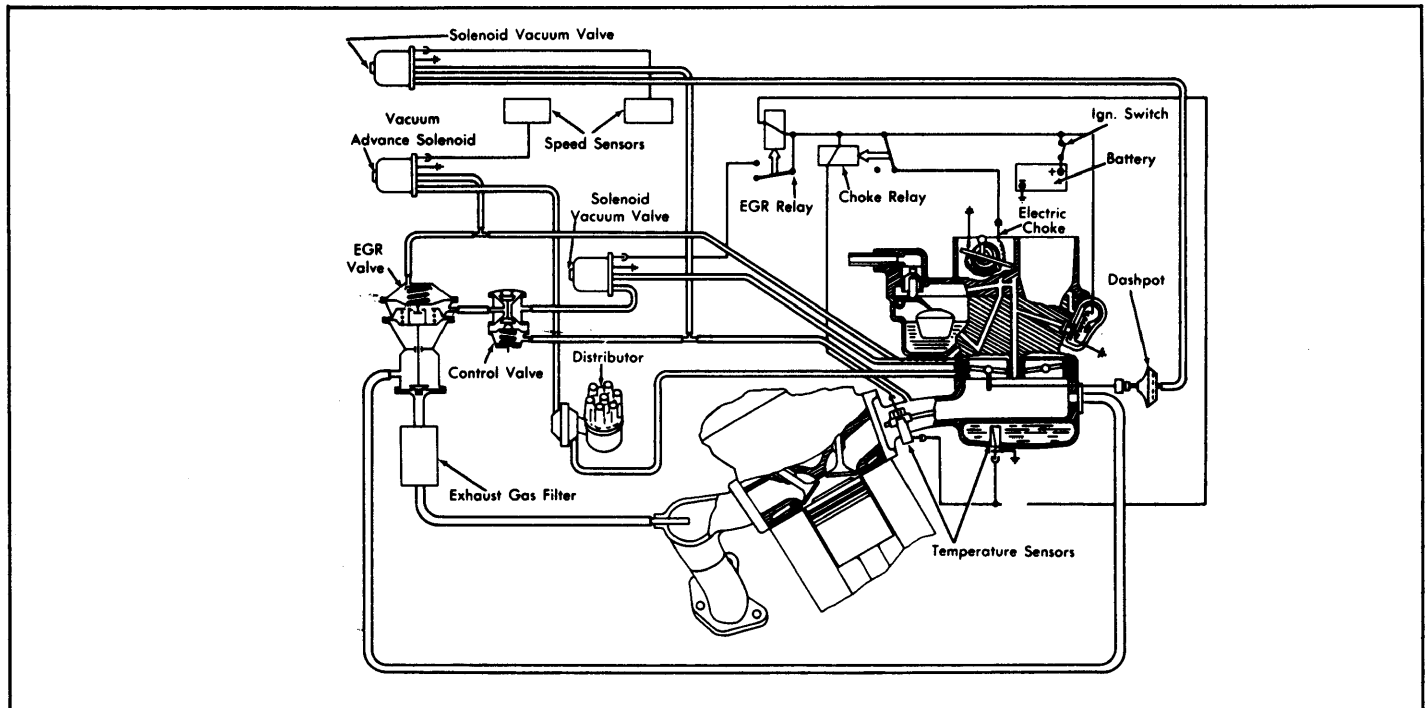

**Fig. 2: 1974 Bavaria, 3.0CS & Sedan Exhaust Emission System**

# 1974-79 EXHAUST EMISSION SYSTEMS

## BMW Vacuum Diagrams (Cont.)

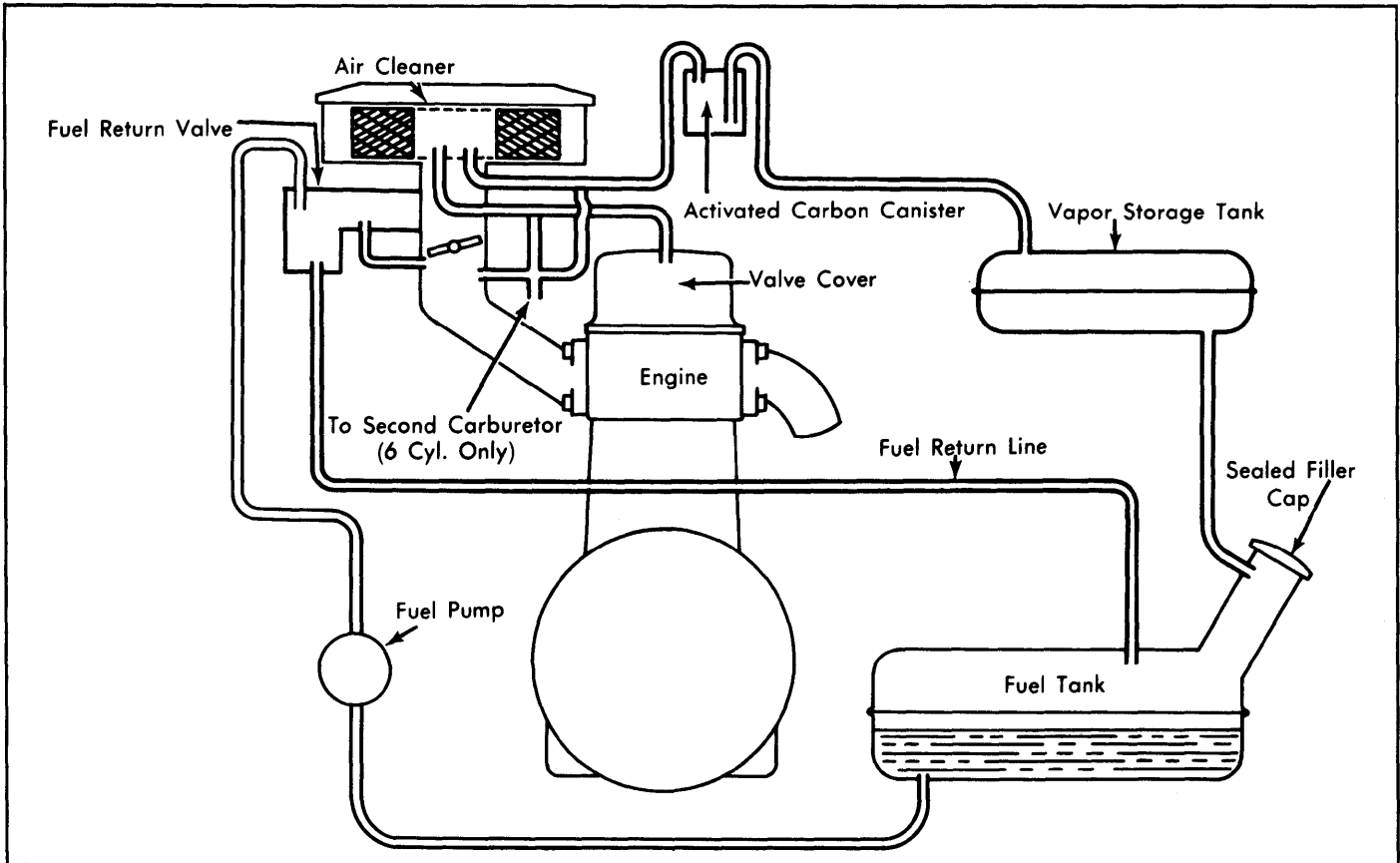

Fig. 3: 1974-76 2002 Fuel Evaporation System

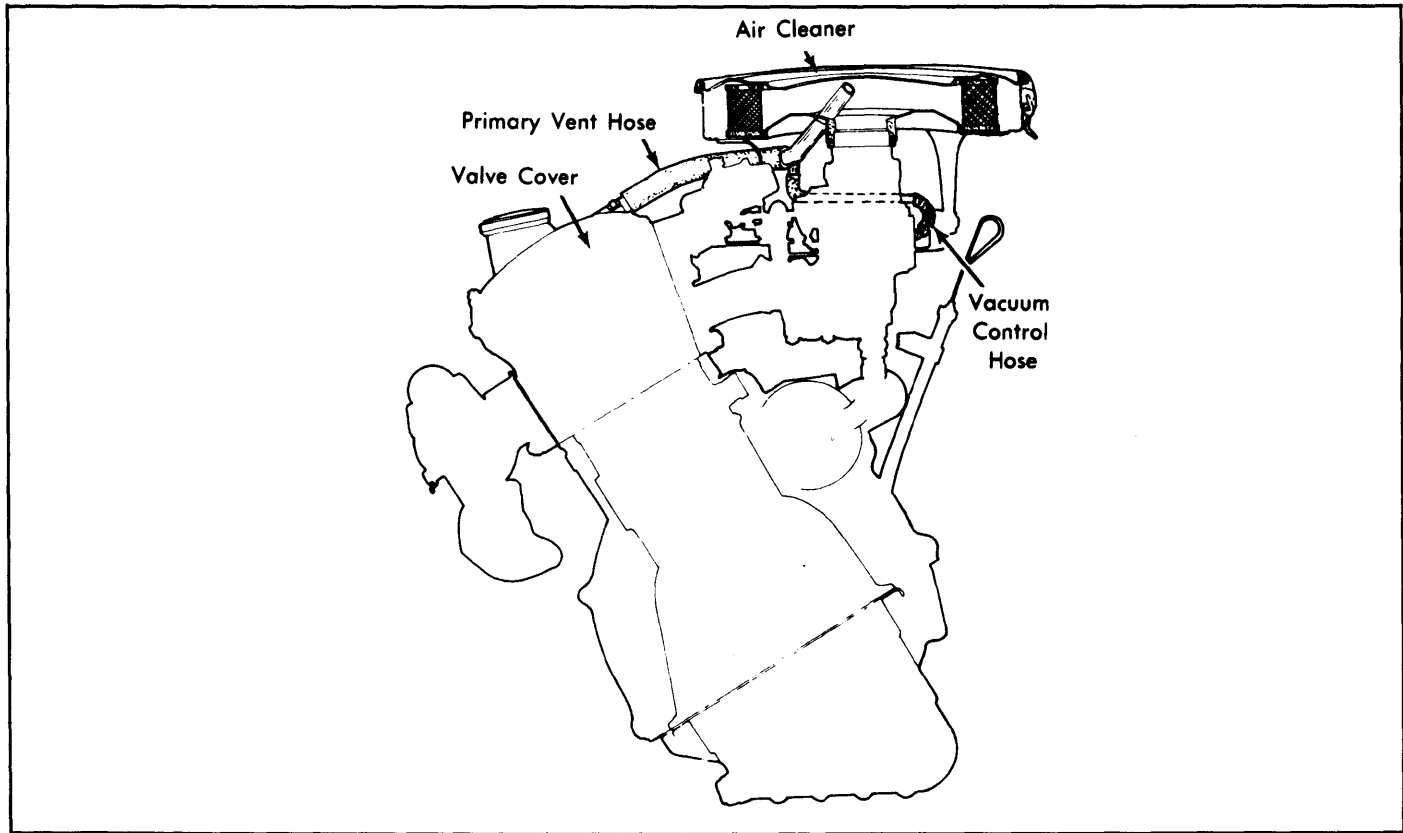
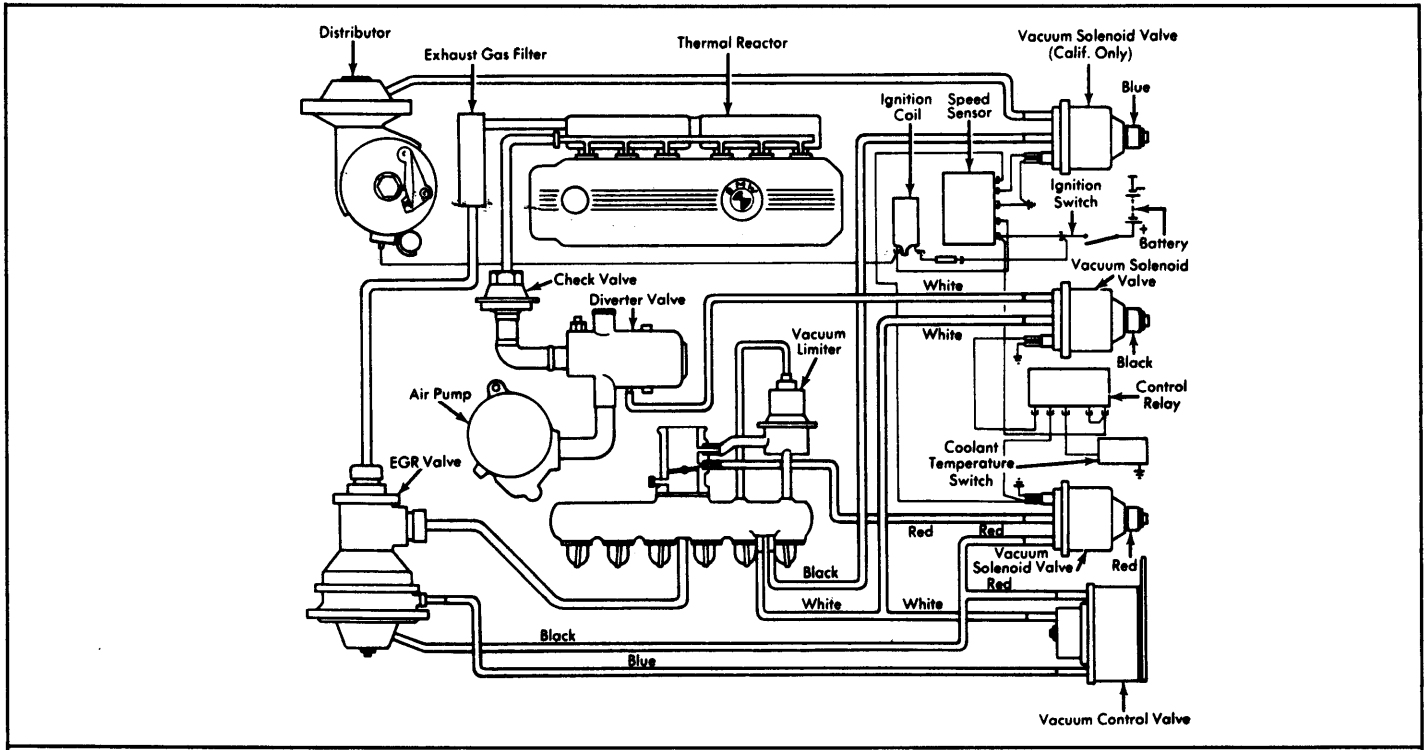

Fig. 4: 1974-76 Positive Crankcase Ventilation System

# 1974-79 EXHAUST EMISSION SYSTEMS

## BMW Vacuum Diagrams (Cont.)



**Fig. 5: 1975 530i & 3.0Si Exhaust Emission System**

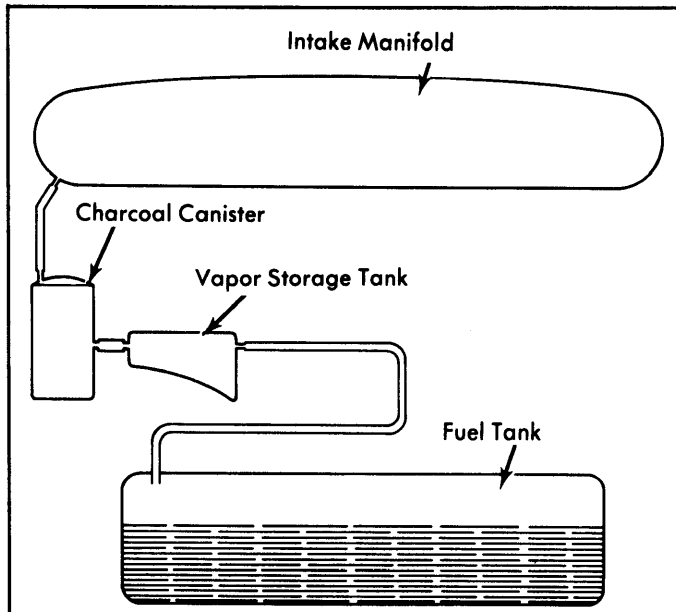

**Fig. 6: 1975-76 530i & 3.0Si Fuel Evaporation System**

# 1974-79 EXHAUST EMISSION SYSTEMS

## BMW Vacuum Diagrams (Cont.)

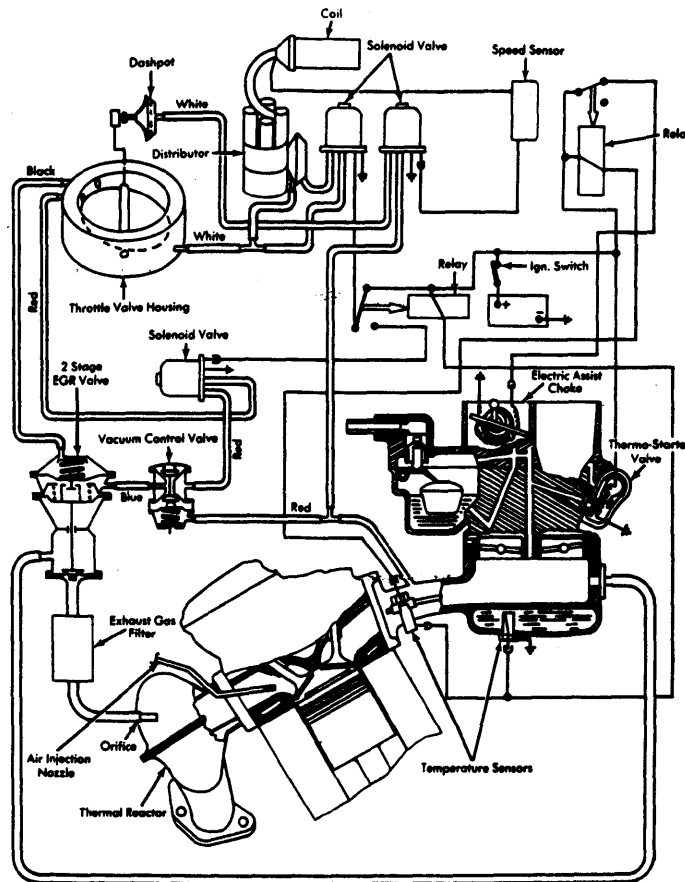

Fig. 7: 1975 2002 Exhaust Emission System

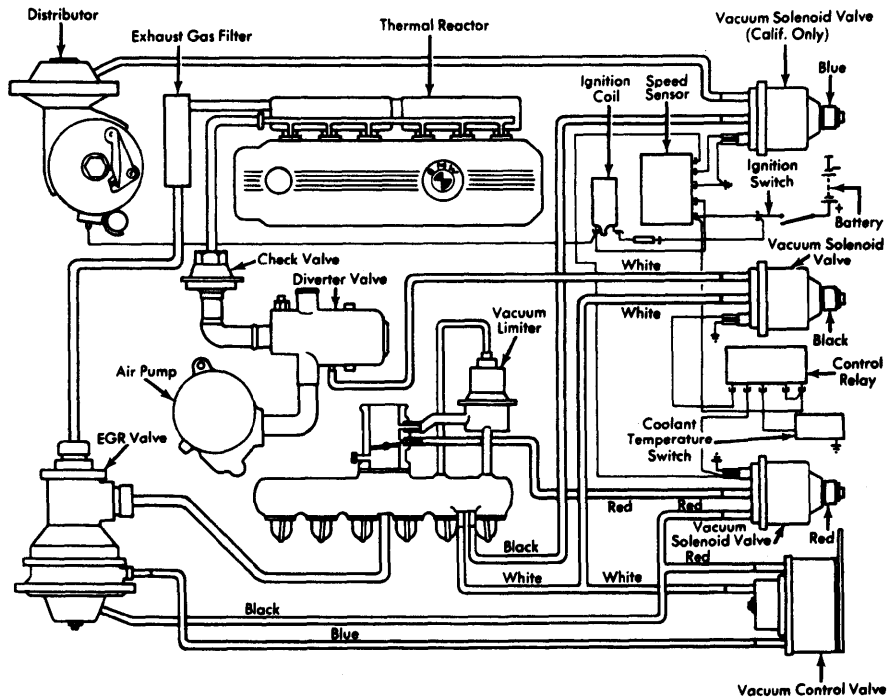

Fig. 8: 1976 530i & 3.0Si Exhaust Emission System

# 1974-79 EXHAUST EMISSION SYSTEMS BMW Vacuum Diagrams (Cont.)

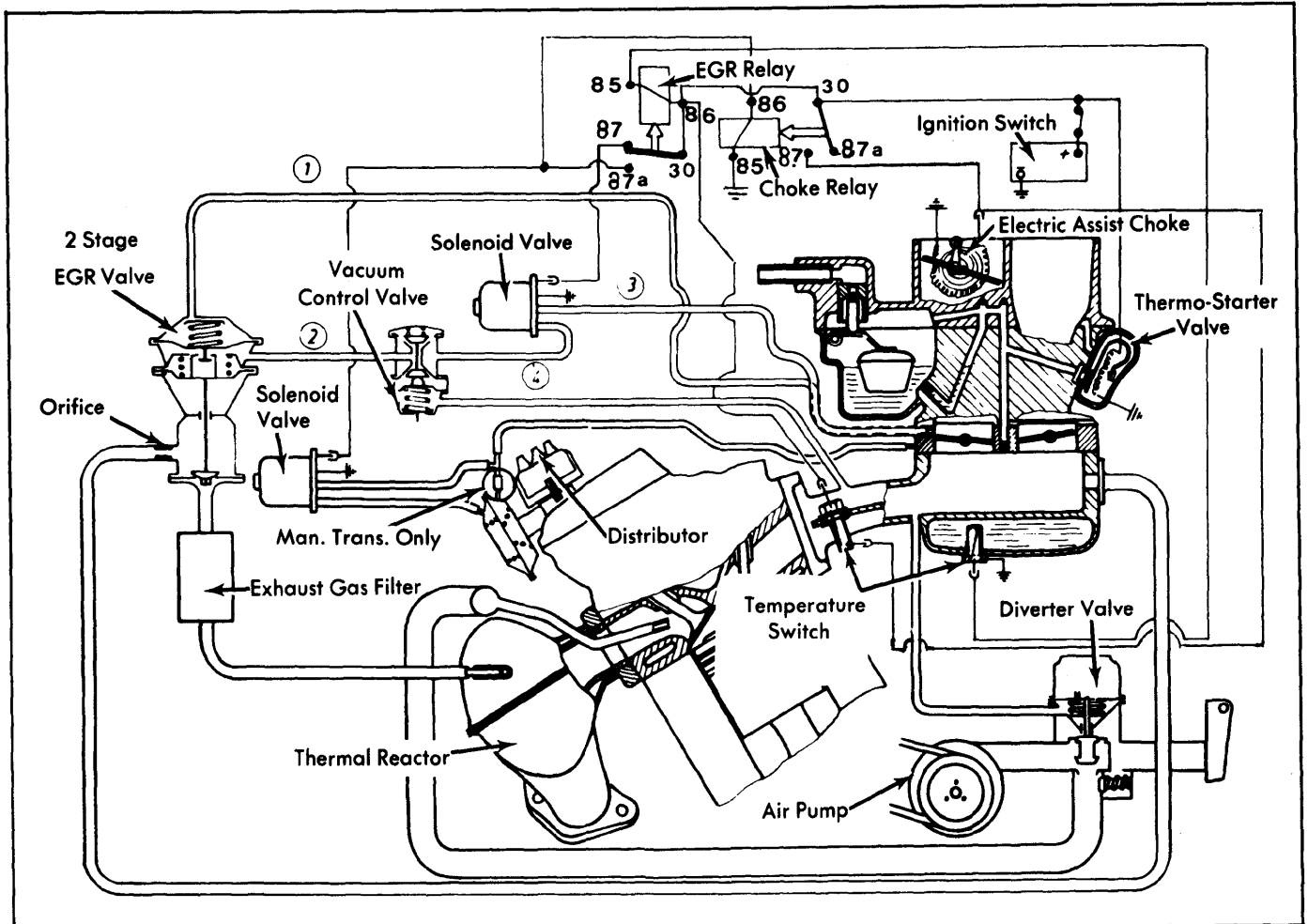

Fig. 9: 1976 2002 Exhaust Emission System (California)

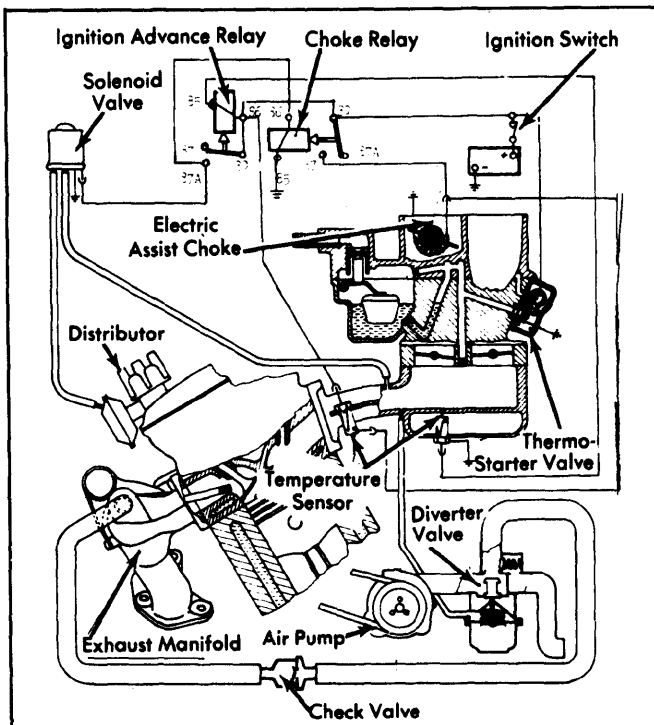
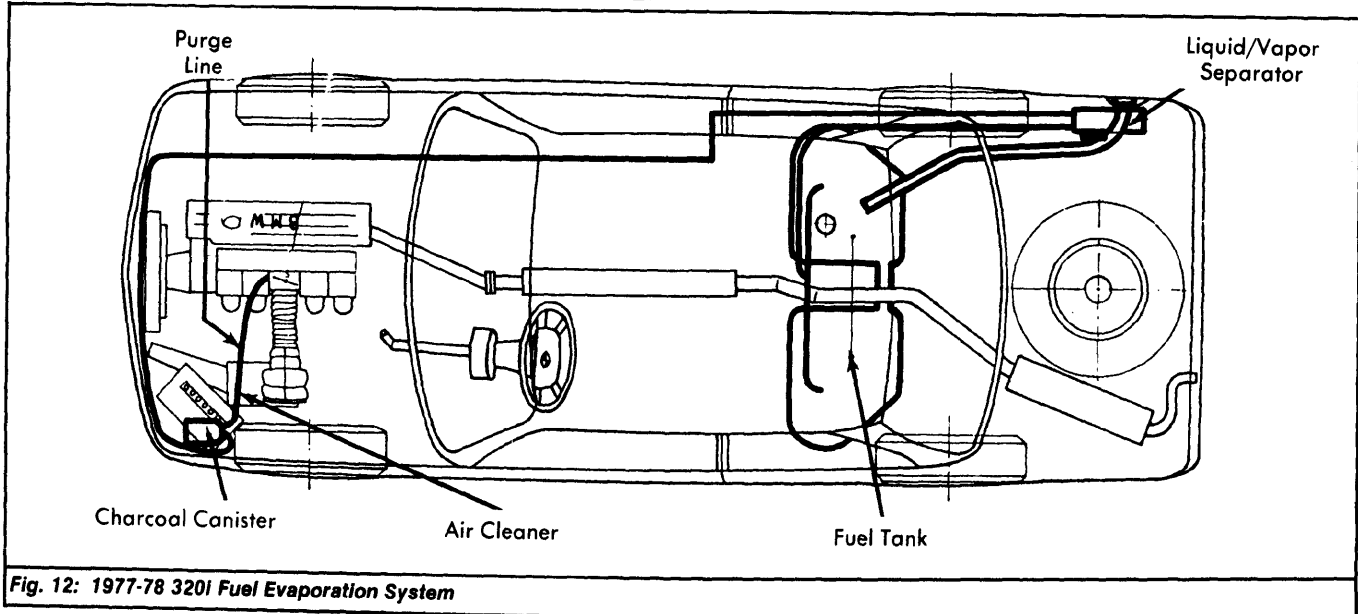
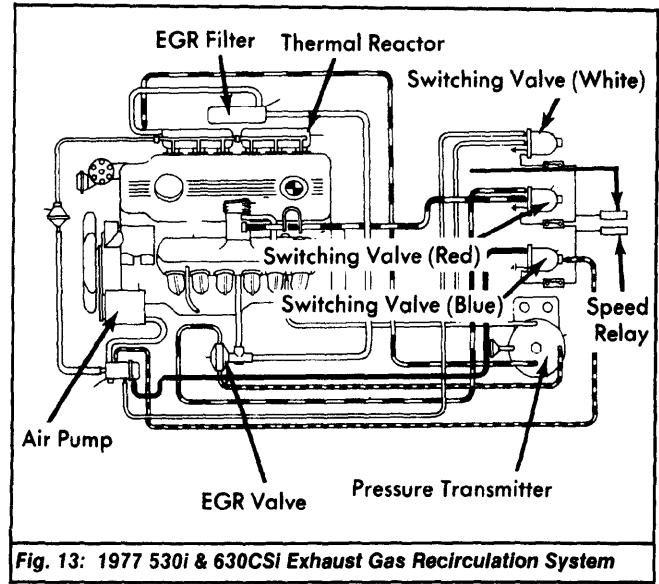
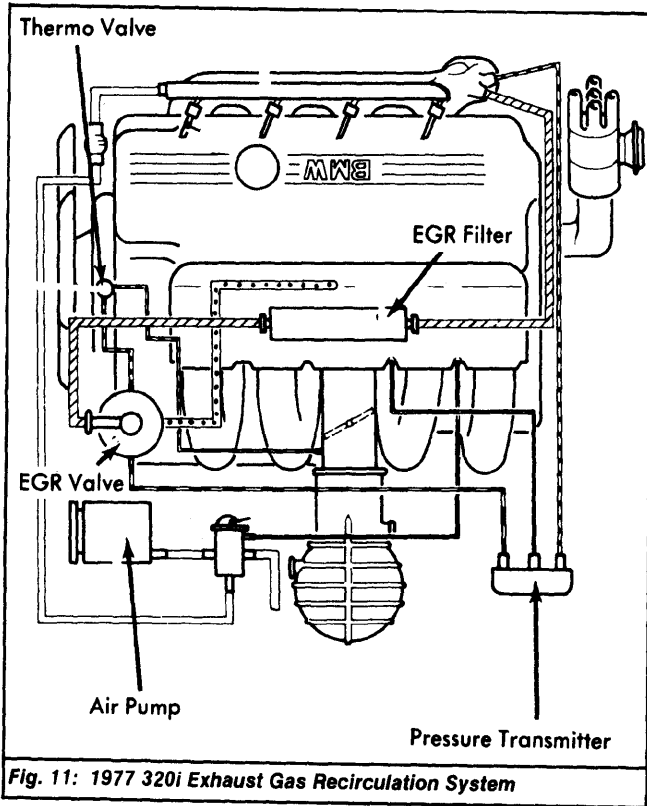

Fig. 10: 1976 2002 Exhaust Emission System (Federal)

# 1974-79 EXHAUST EMISSION SYSTEMS

## BMW Vacuum Diagrams (Cont.)



# 1974-79 EXHAUST EMISSION SYSTEMS

## BMW Vacuum Diagrams (Cont.)

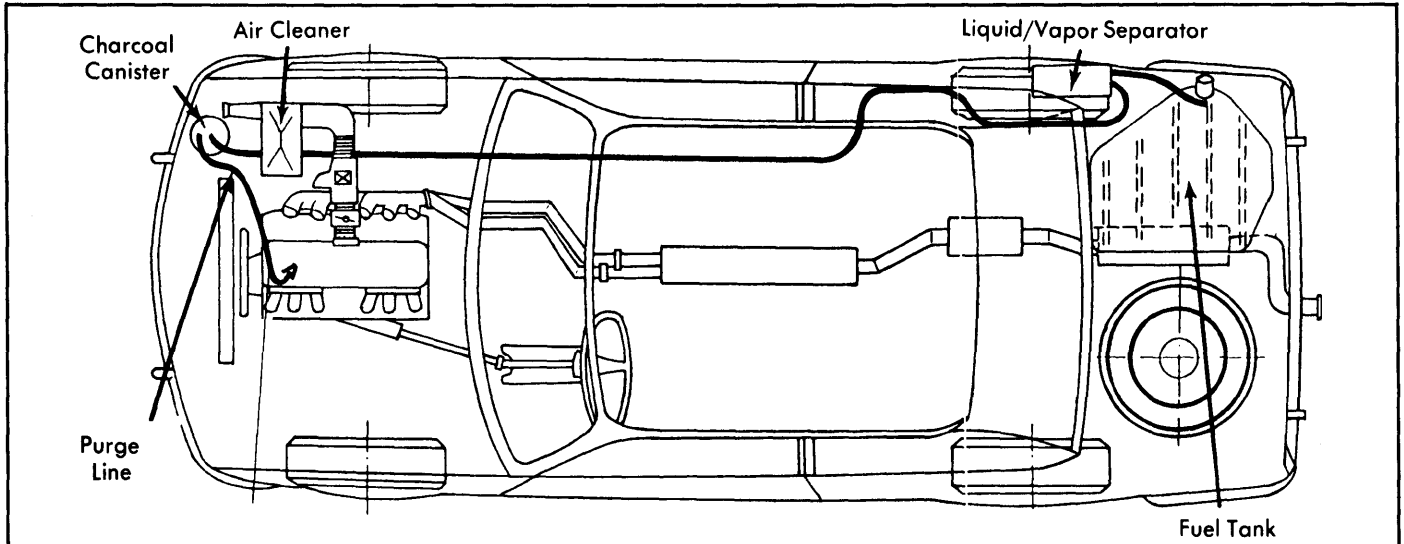

Fig. 14: 1977-78 530i Fuel Evaporation System (633CSI Similar)

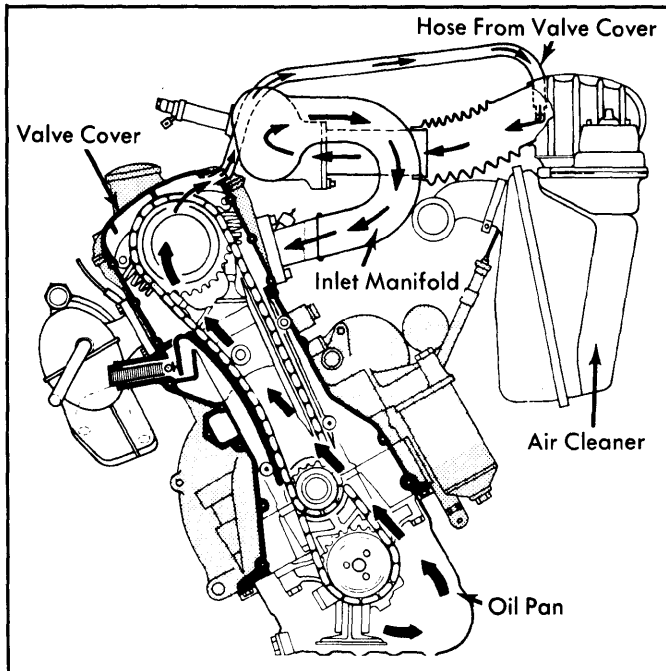

Fig. 15: 1977-78 320i Positive Crankcase Ventilation System

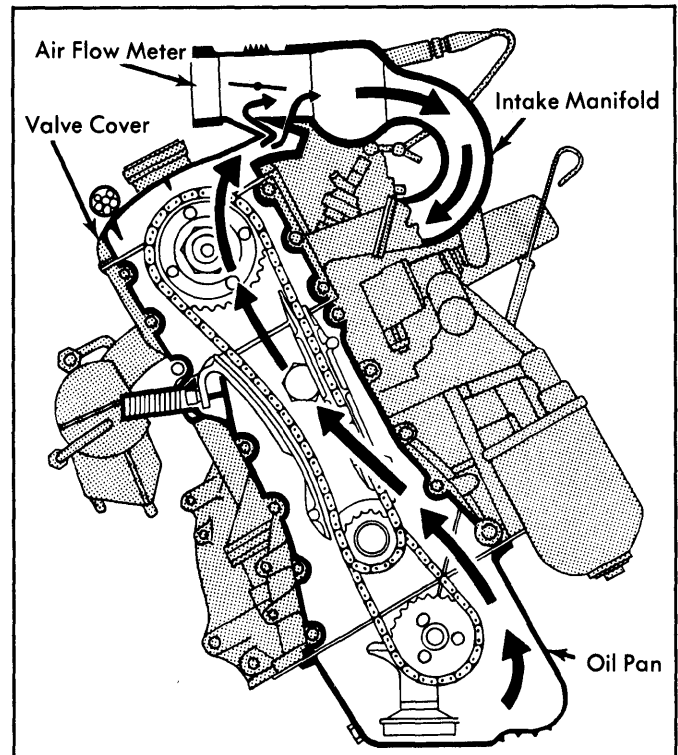

Fig. 16: 1977-78 530i Positive Crankcase Ventilation System

# 1974-79 EXHAUST EMISSION SYSTEMS BMW Vacuum Diagrams (Cont.)

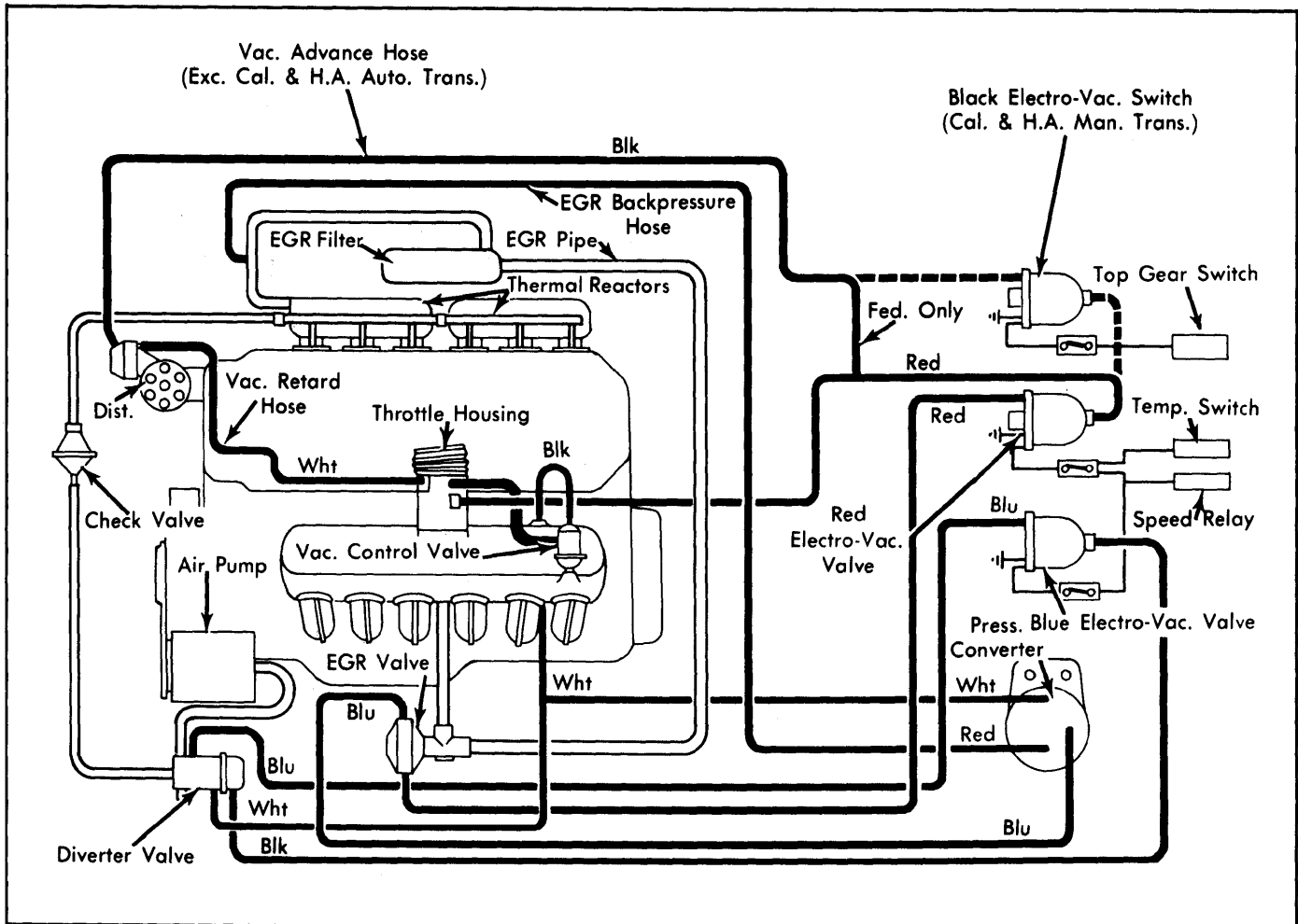

Fig. 17: 1978 733i Exhaust Emission System

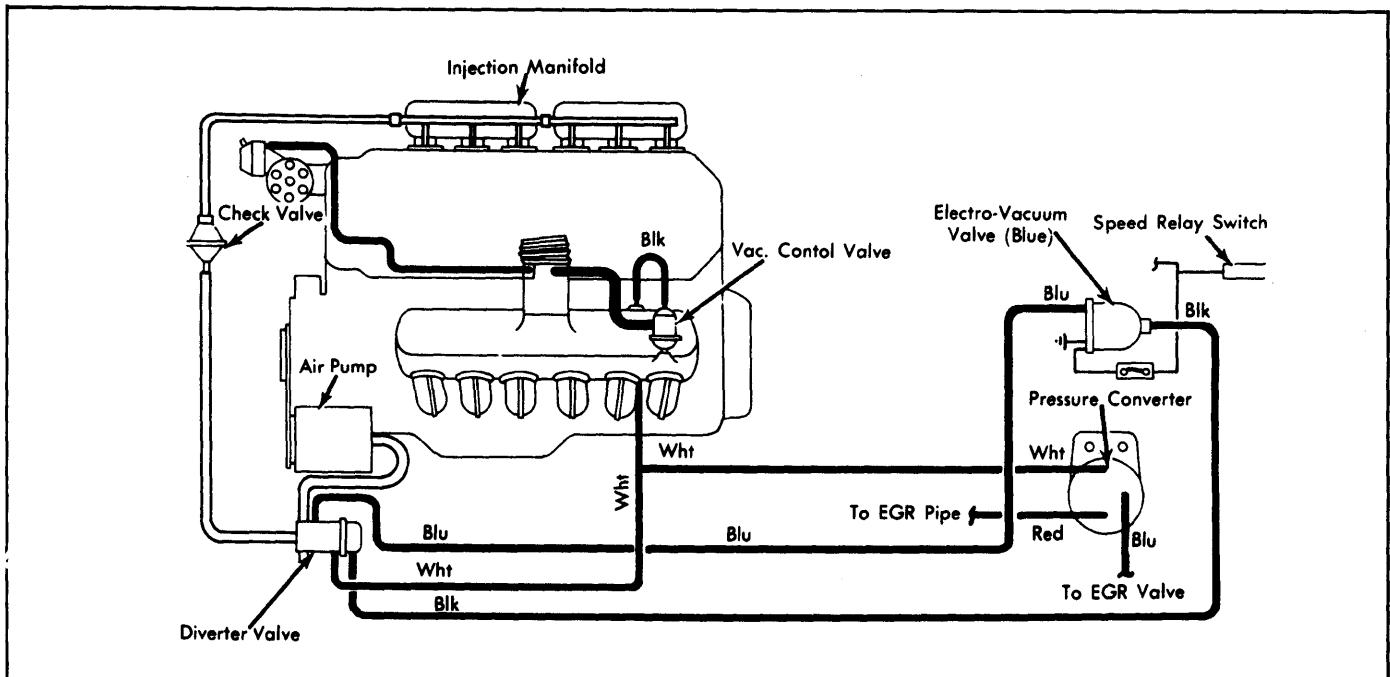

Fig. 18: 1978 733i Air Injection System

# 1974-79 EXHAUST EMISSION SYSTEMS

## BMW Vacuum Diagrams (Cont.)

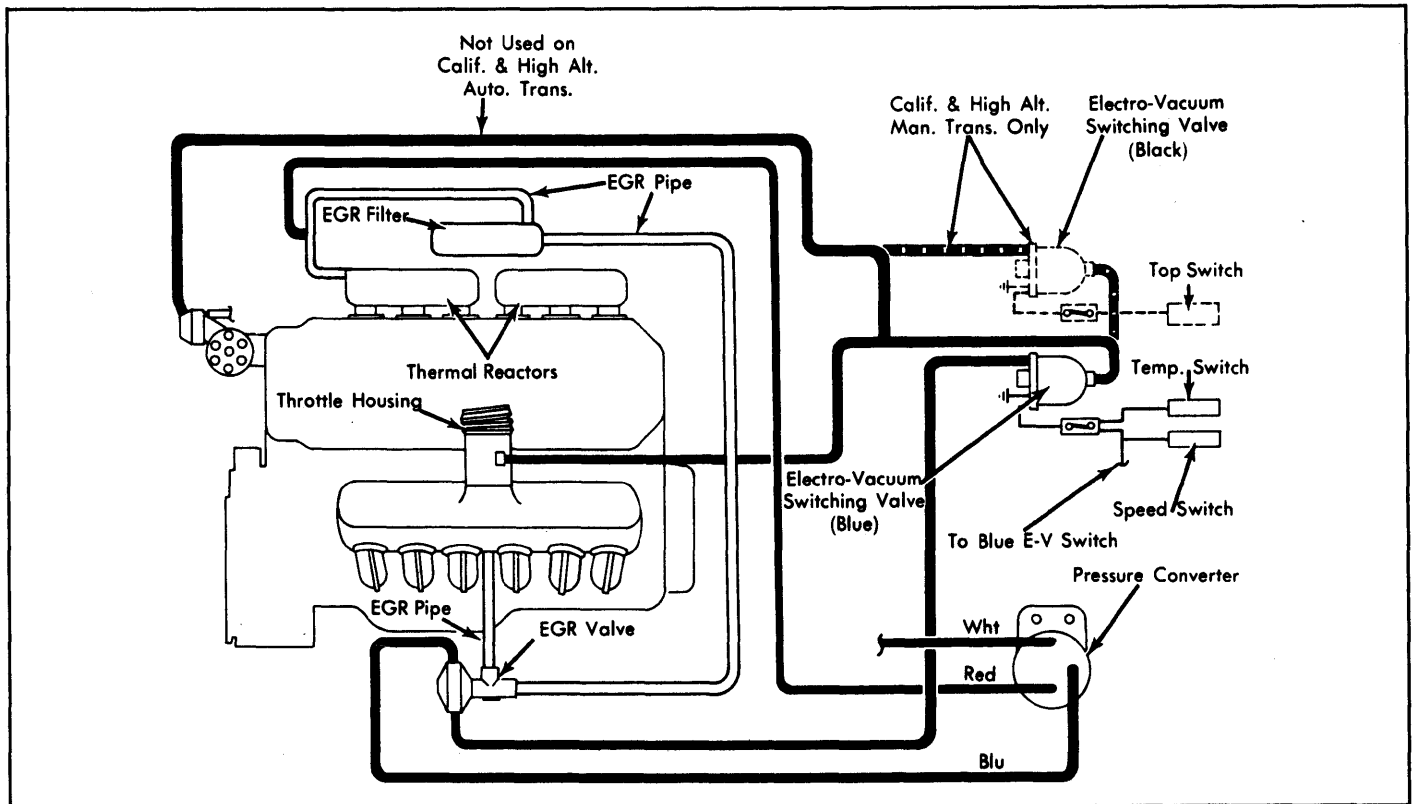

Fig. 19: 1978 733i Exhaust Gas Recirculation System

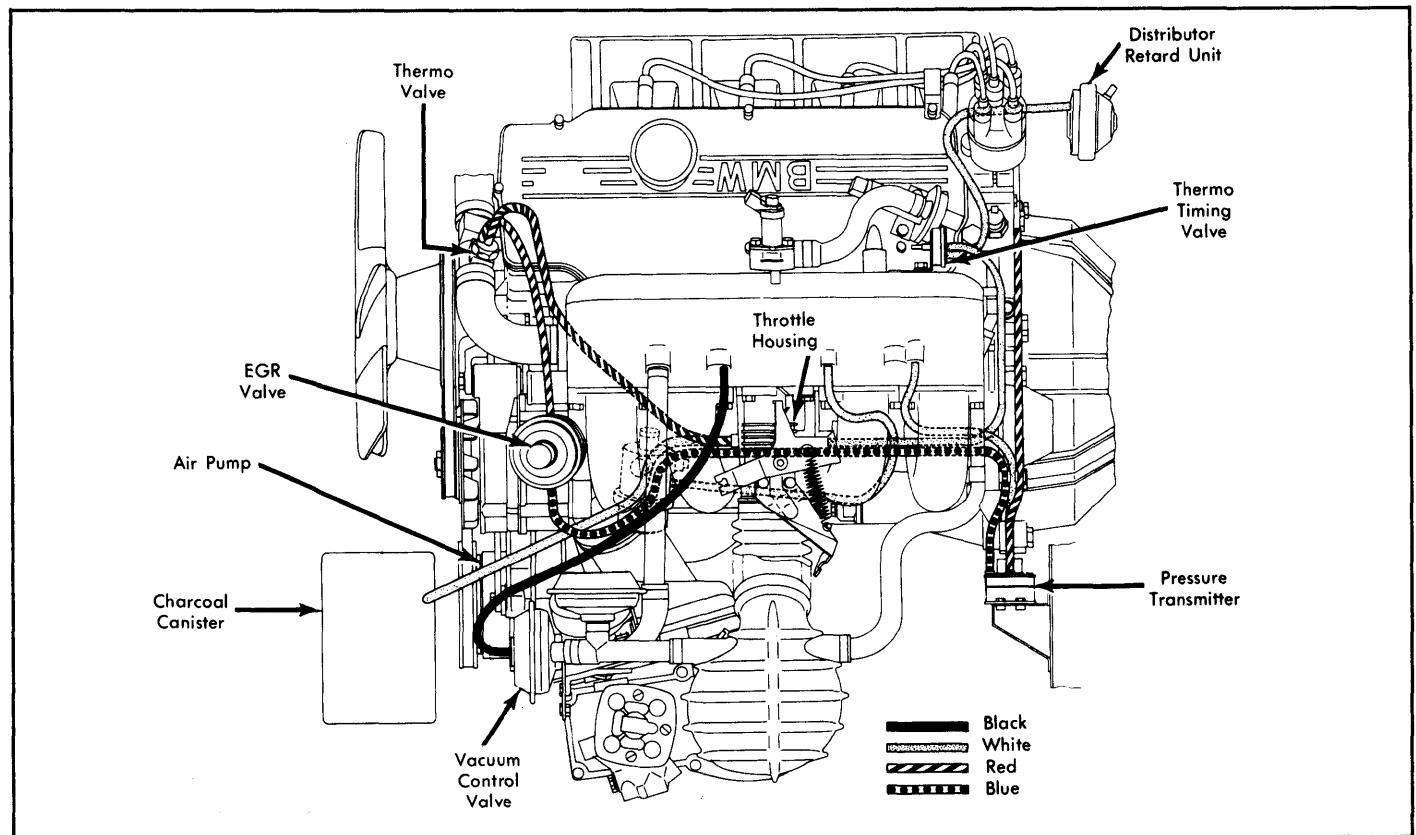
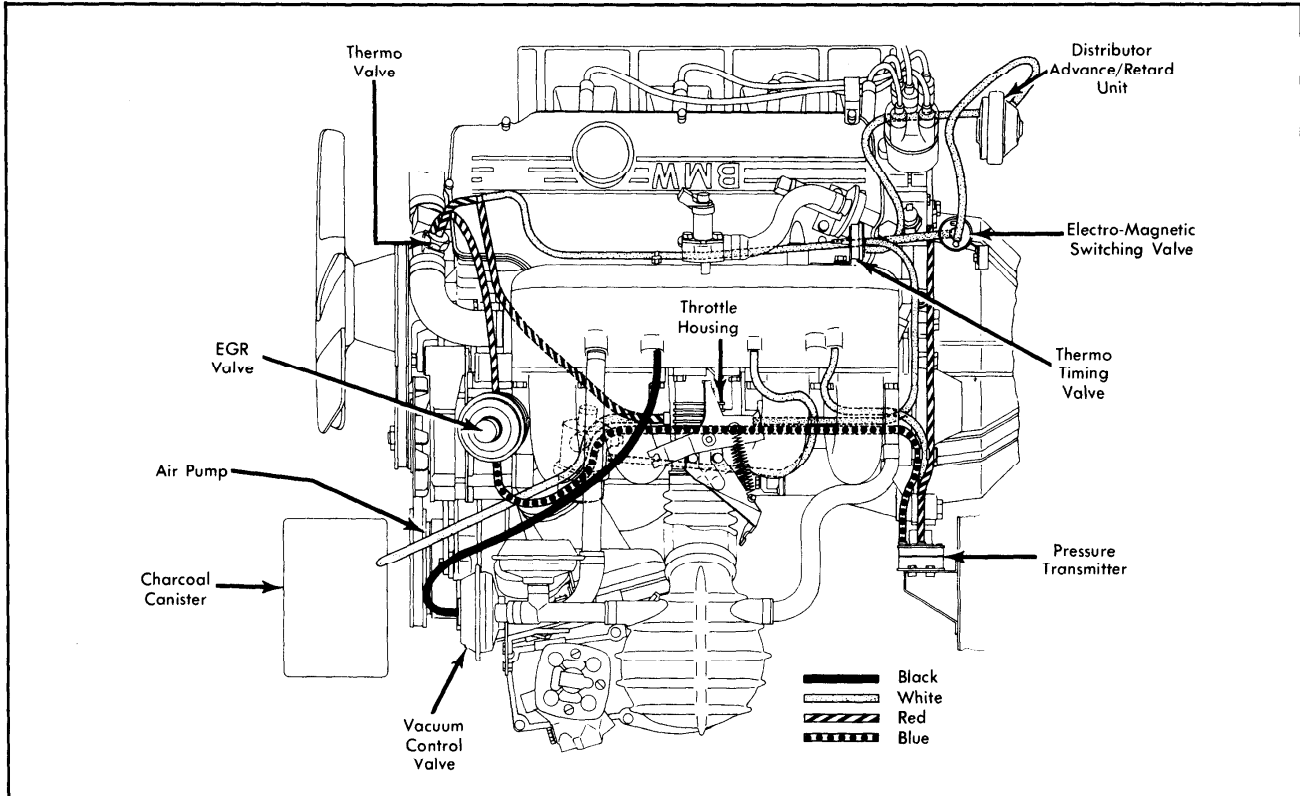

Fig. 20: 1979 320i Exhaust Emission System (Auto. Trans.)

# 1974-79 EXHAUST EMISSION SYSTEMS

## BMW Vacuum Diagrams (Cont.)



**Fig. 21: 1979 320i Exhaust Emission System (Man. Trans.)**

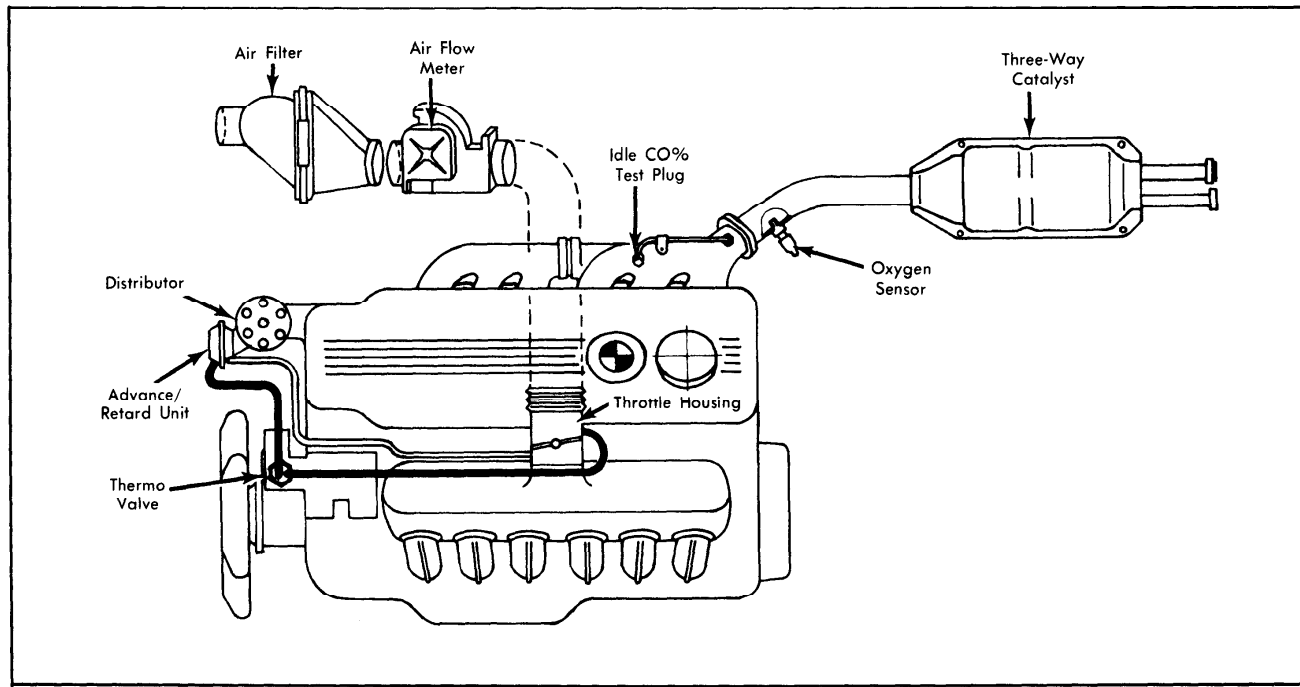

**Fig. 22: 1979 528i Exhaust Emission System**

# 1974-79 EXHAUST EMISSION SYSTEMS

## BMW Vacuum Diagrams (Cont.)

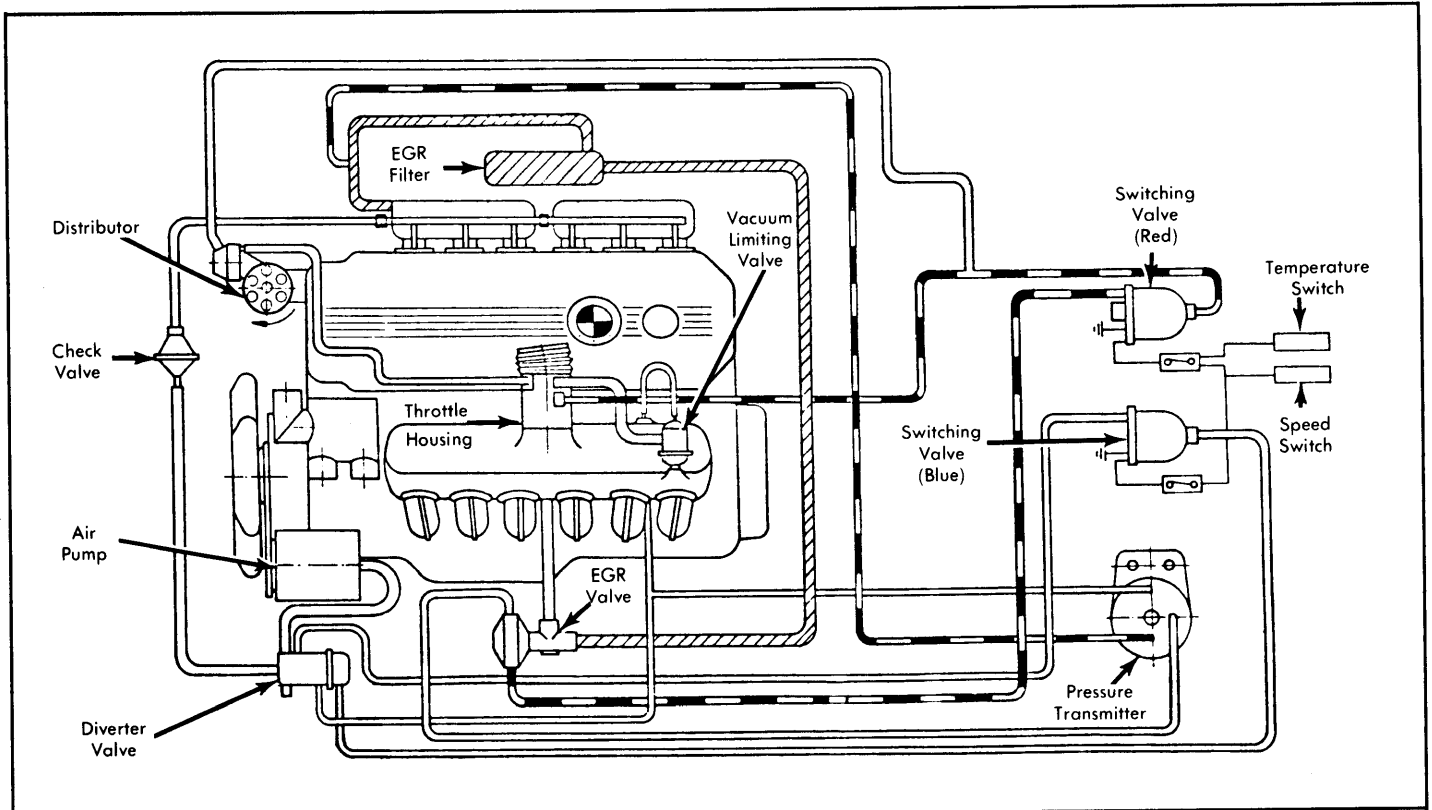

Fig. 23: 1979 633CSI & 733i Exhaust Emission System

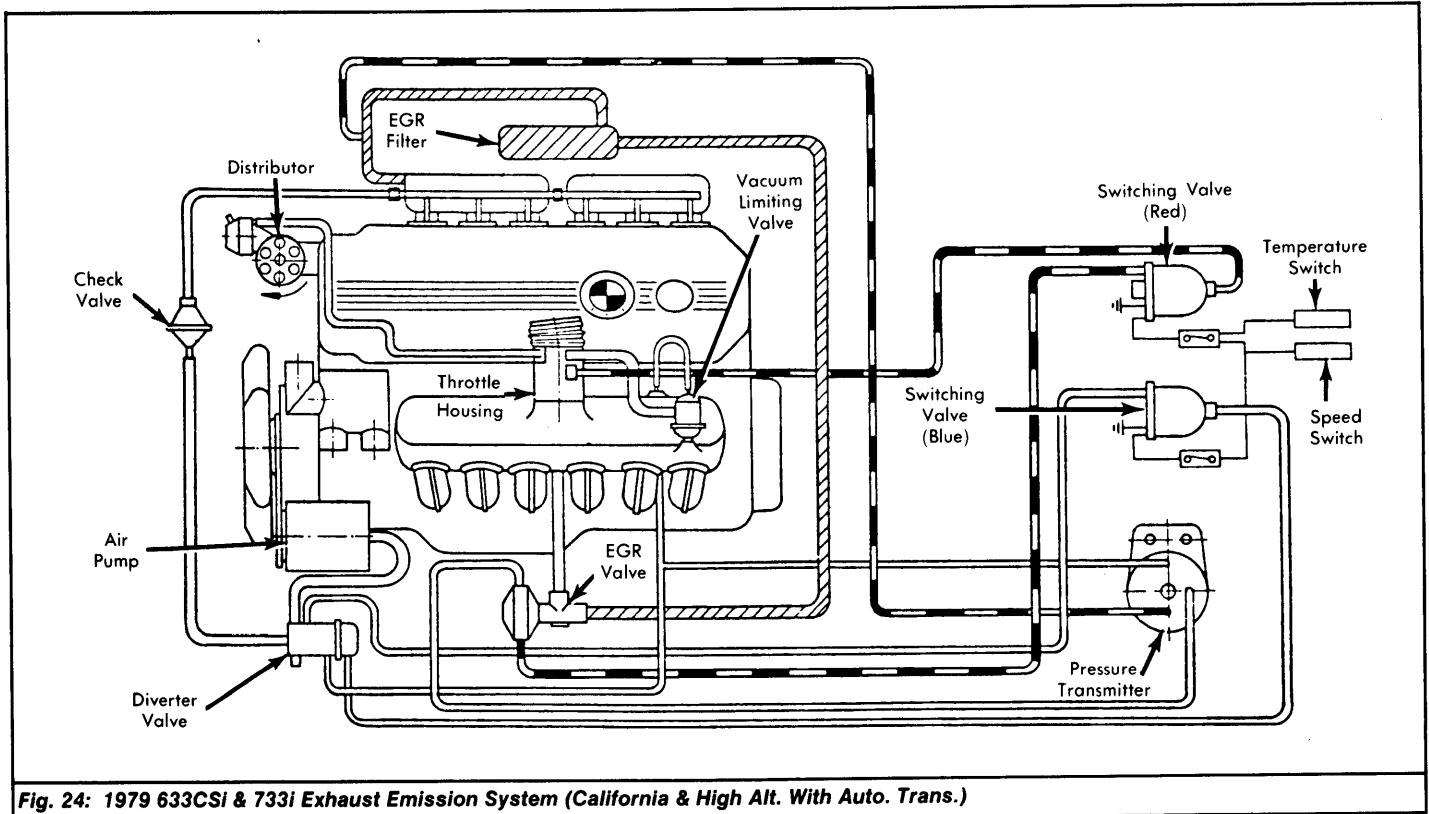

Fig. 24: 1979 633CSI & 733i Exhaust Emission System (California & High Alt. With Auto. Trans.)

# 1974-79 EXHAUST EMISSION SYSTEMS BMW Vacuum Diagrams (Cont.)

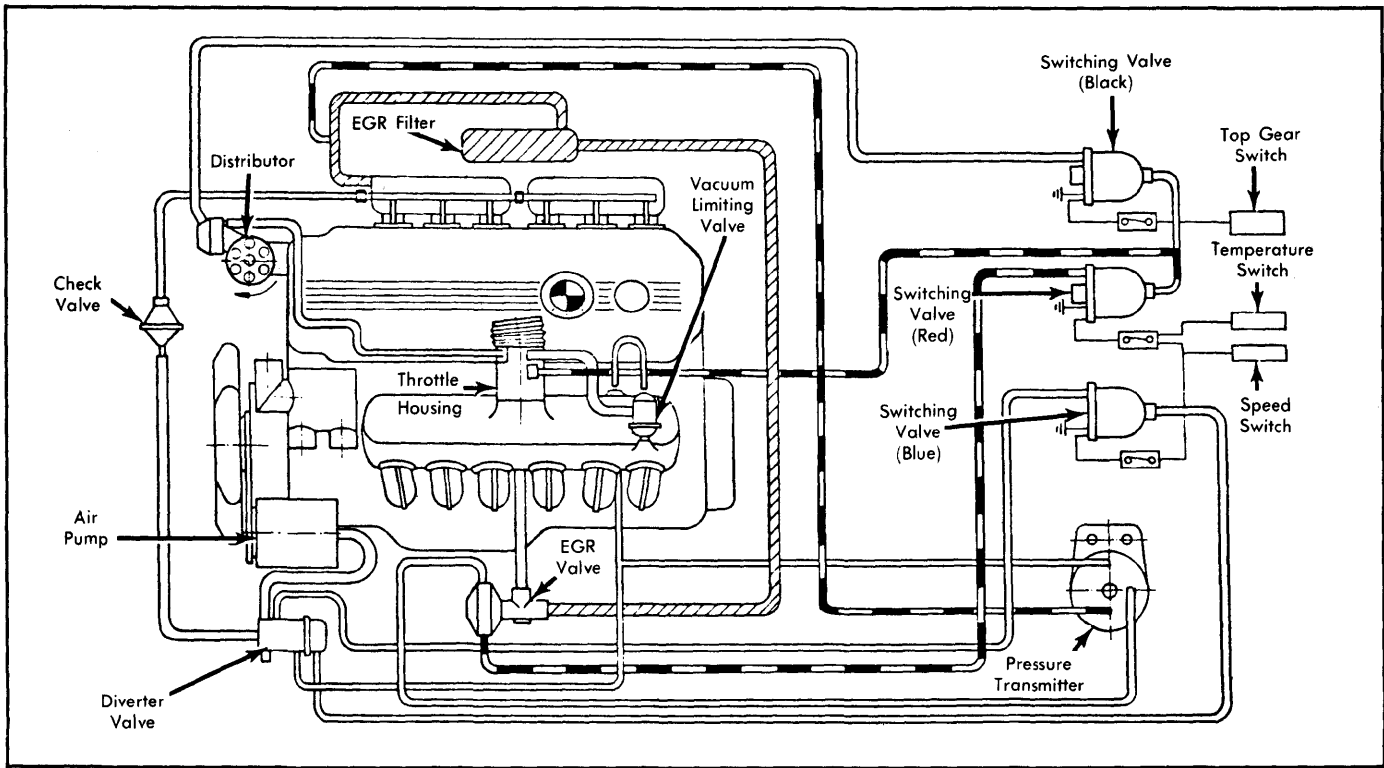

Fig. 25: 1979 633CSI & 733i Exhaust Emission System (California & High Alt. With Man. Trans.)