

1974-79 EXHAUST EMISSION SYSTEMS

BMW Fuel Evaporation

All Models

DESCRIPTION

System consists of purge lines from fuel tank to crankcase ventilation system. Located between fuel tank and crankcase ventilation system is a vapor storage tank and an activated carbon canister. Fuel evaporation emissions are prevented from entering atmosphere by means of a sealed filler cap on fuel tank. Fuel tank has no direct vent to atmosphere. An excess fuel return valve is also used, located in fuel supply line near carburetor. A fuel return line connects this valve to fuel tank.

OPERATION

When engine is off, fuel vapors are collected in vapor storage tank. Some vapors are condensed in storage tank and flow back into fuel tank. Excess vapors continue to charcoal canister, where they are absorbed. When engine is started, vacuum in intake manifold draws vapor from canister and storage tank. These vapors are then drawn into the engine and burned. Vapor storage tank also allows for fuel expansion of a completely filled fuel tank.

MAINTENANCE

Every 12,500 miles, check fuel cap, tank, and all connections for tightness. Clean air filter ring in charcoal canister.

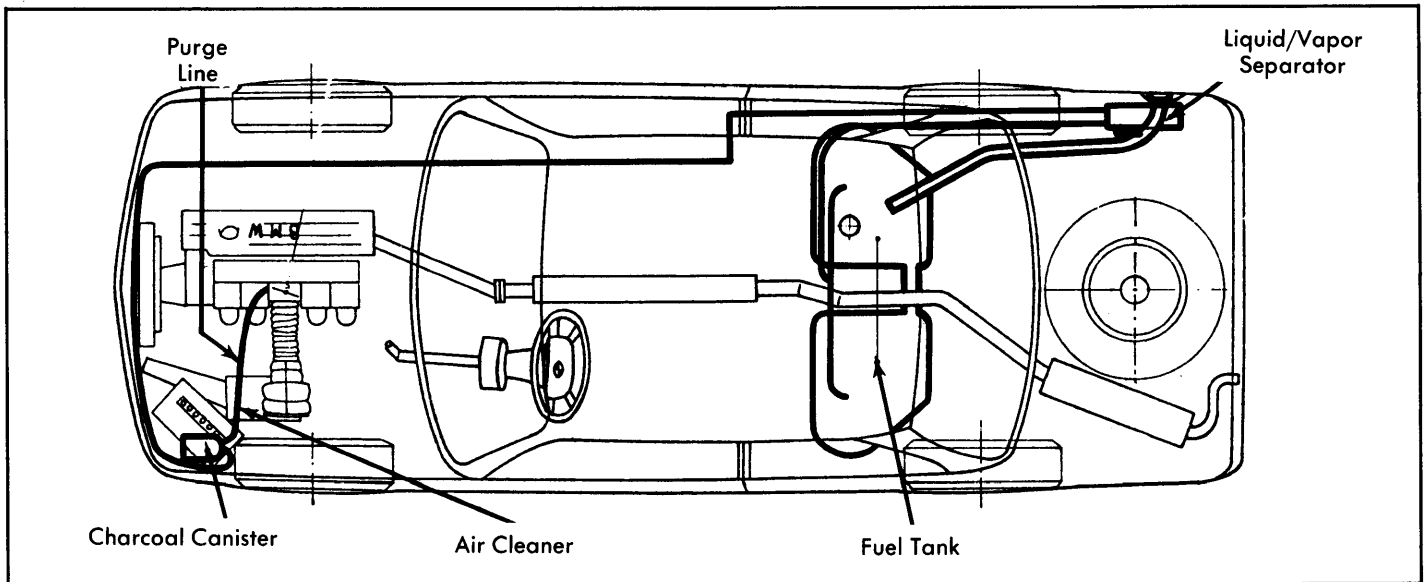

Fig. 1: 320i Fuel Evaporation System

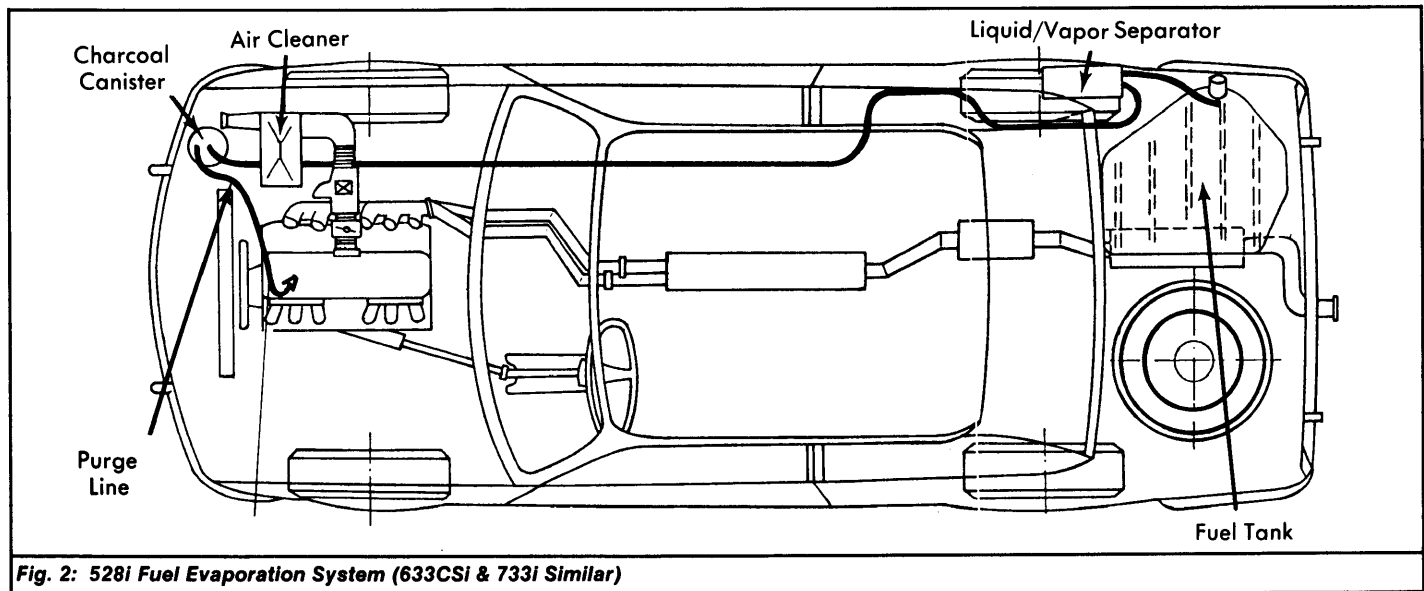

Fig. 2: 528i Fuel Evaporation System (633CSI & 733i Similar)

1974-79 EXHAUST EMISSION SYSTEMS

BMW Fuel Evaporation (Cont.)

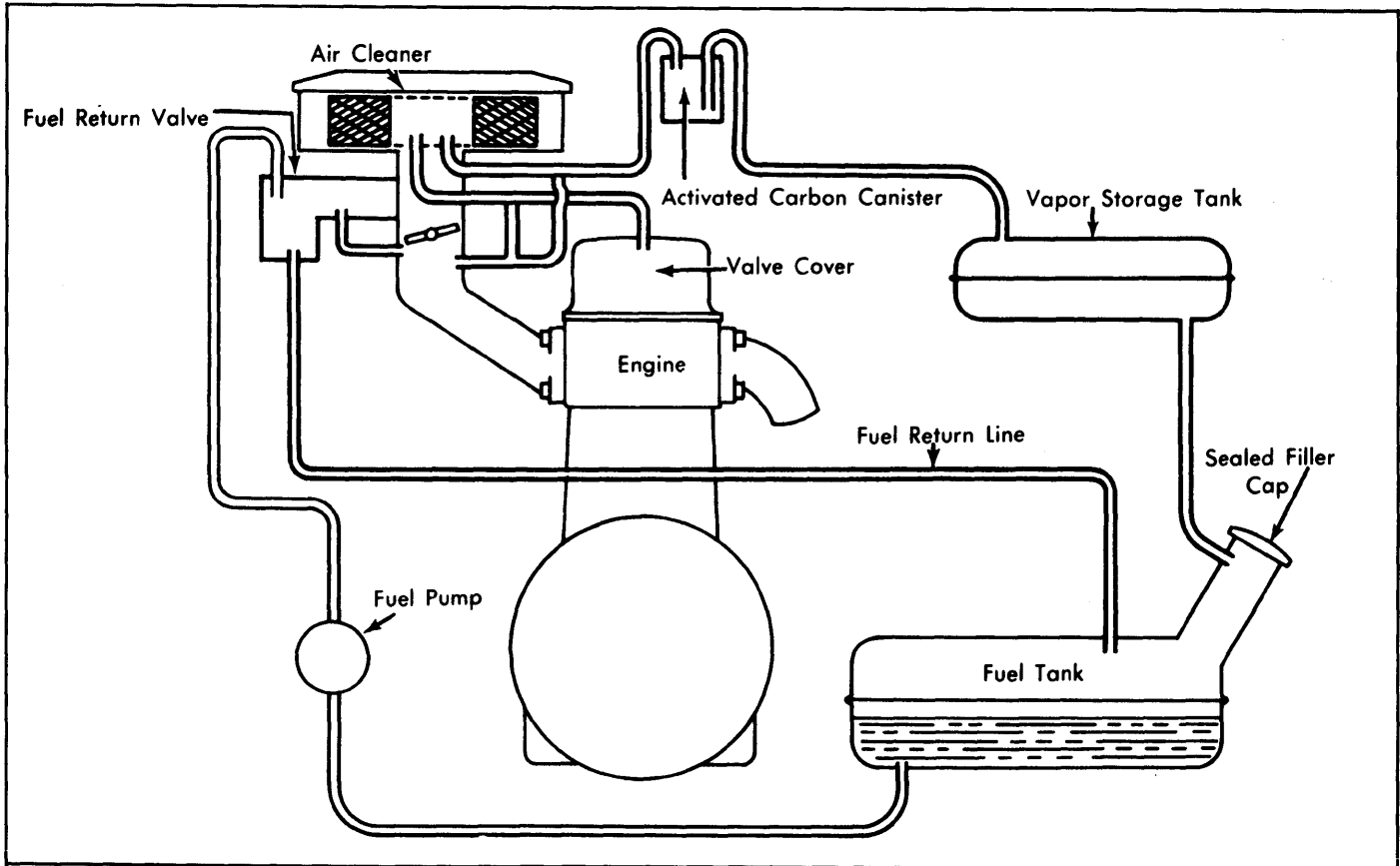

Fig. 3: 2002 Fuel Evaporation System

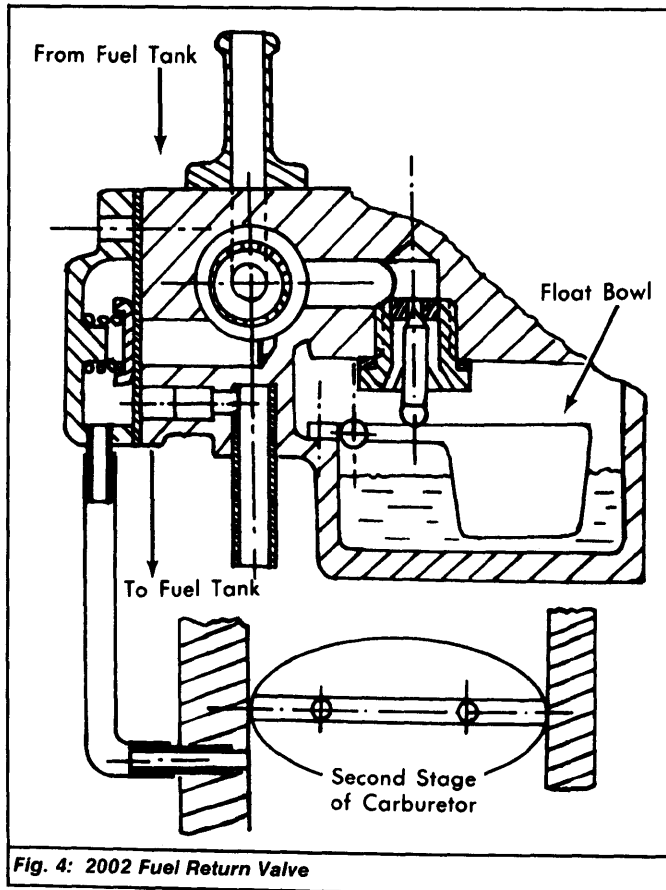

Fig. 4: 2002 Fuel Return Valve

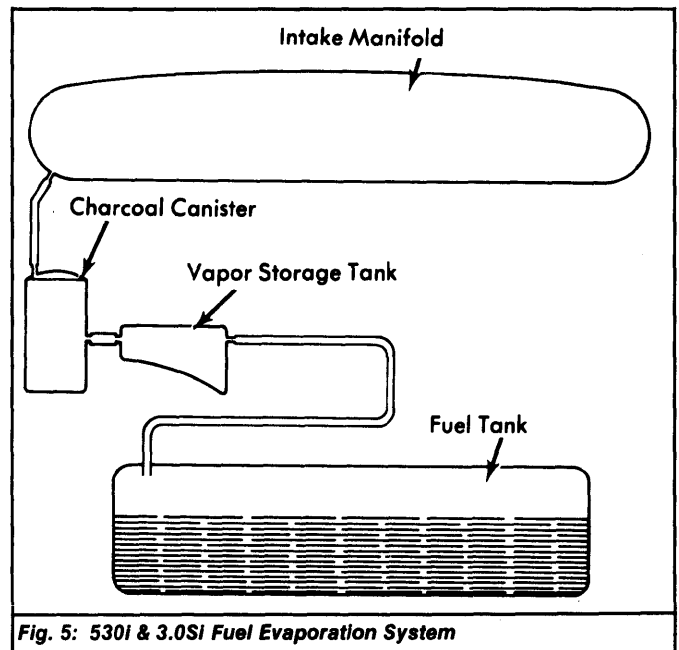

Fig. 5: 530i & 3.0SI Fuel Evaporation System