

1974-79 EXHAUST EMISSION SYSTEMS

Air Injection Systems

1975-78 All Manufacturers

NOTE: Some 1979 air injection systems are covered individually. See applicable **AIR INJECTION SYSTEM** articles in this section.

DESCRIPTION

A manifold air injection system is used to reduce hydrocarbon (HC) and carbon monoxide (CO). The system adds a controlled amount of air to exhaust gases at the exhaust ports, causing oxidation of gases. On some models, air injection is used in conjunction with a catalytic converter or thermal reactor. The air injection system consists of a belt driven air pump, connecting hoses, check valve(s), and an anti-backfire suppressor valve (either on anti-backfire or diverter valve). Some models will incorporate other unique control devices which are discussed at the end of this article.

OPERATION

Inlet air to air pump is drawn in through either engine air cleaner, a separate air pump air cleaner or a centrifugal fan filter at front of air pump. Pressurized air leaving air pump is transmitted through hoses, check valve(s) and air manifold(s) to individual exhaust ports or to exhaust manifold, in front of exhaust pipe flange, on some vehicles. Fresh air ignites and burns unburned portion of exhaust gases in exhaust system, thus reducing exhaust emissions.

AIR PUMP

Air pump is belt driven and generally mounted on the front of the engine with power take-off at the crankshaft pulley. Intake air passes through filtering device and is delivered to the injection manifold by a rubber hose. Some models utilize a pressure relief valve in air pump body, while others have a relief valve in combustion with a diverter valve.

CHECK VALVE & RELIEF VALVE

The relief valve vents excessive pressure which may build up in air injection system. The check valve has a one-way diaphragm which prevents hot exhaust gases from backing up into hose and pump. Valve protects system in case of pump belt failure, high exhaust system pressure, or air hose ruptures.

ANTI-BACKFIRE VALVE

When throttle is closed suddenly, carburetor air is shut off instantly but fuel flows momentarily which results in a rich mixture. To eliminate backfire, anti-backfire valve opens momentarily to allow air from air

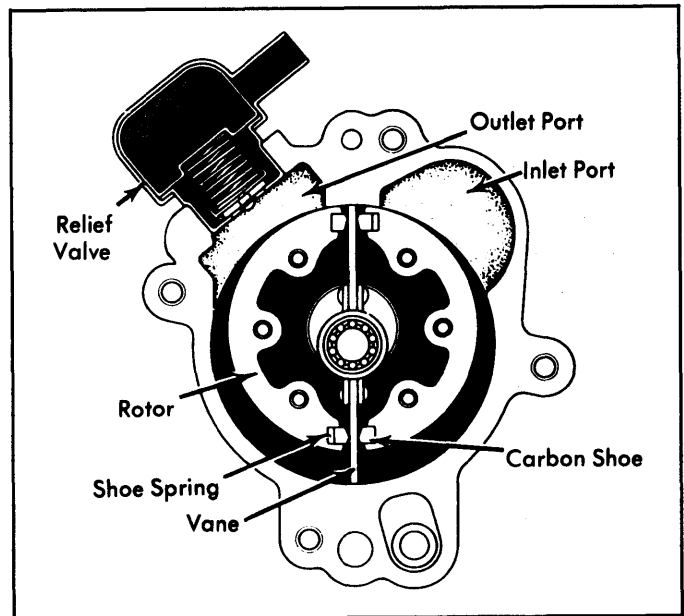

Fig. 2: Air Pump (With External Relief Valve)

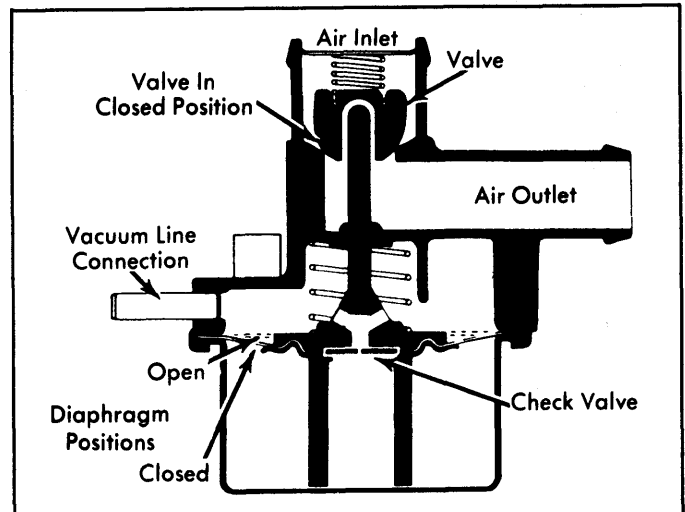

Fig. 3: Anti-Backfire Valve (Typical)

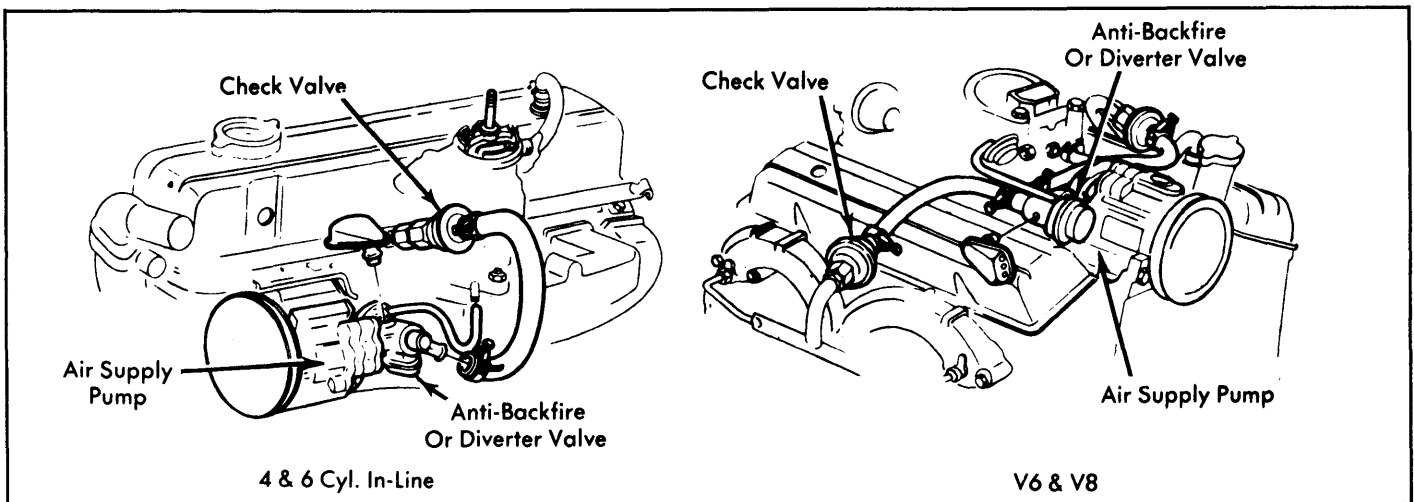

Fig. 1: Typical Air Injection System

1974-79 EXHAUST EMISSION SYSTEMS

Air Injection Systems (Cont.)

pump to enter intake manifold and lean mixture. Opening of valve is triggered whenever there is a rapid rise in intake manifold vacuum. Opening of this valve also prevents rapid reduction of engine RPM which assists in eliminating the need of a dashpot.

DIVERTER VALVE

The diverter valve prevents backfire in exhaust system during sudden deceleration. Valve senses sudden increases in intake manifold vacuum, causing valve to open and allowing air from air pump to vent to atmosphere. In some applications a pressure relief valve is incorporated in diverter valve housing.

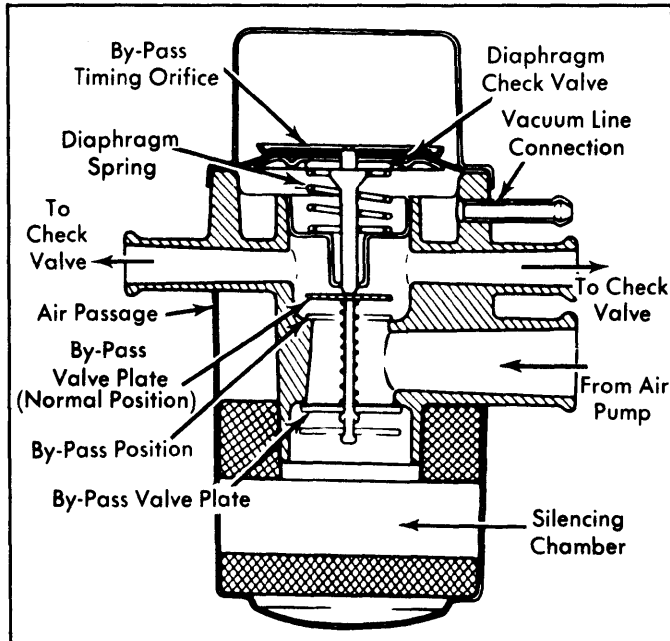

Fig. 4: Diverter Valve (Without Relief Valve)

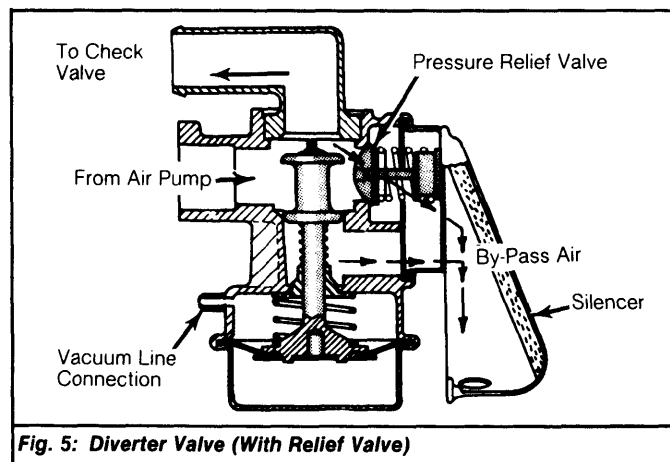

Fig. 5: Diverter Valve (With Relief Valve)

TROUBLE SHOOTING

EXCESSIVE BELT/PUMP NOISE

Loose pump drive belt or seized pump. Leak in hose, loose hose or hose fitting, diverter or anti-backfire valve failure, check valve failure, pump mounting loose, pump or impeller damage.

NO AIR SUPPLY

Loose drive belt, leak in hose or hose fitting, diverter valve or anti-backfire valve failure, check valve failure, pump failure.

EXHAUST BACKFIRE

Incorrect engine tune-up, engine vacuum leaks, faulty anti-backfire or diverter valve, faulty check valve.

TESTING

ANTI-BACKFIRE VALVE

Check valve by removing large hose from valve which connects to air pump. With finger placed over open end of hose (not valve), accelerate engine and allow throttle to close rapidly. Valve is operating properly if a momentary rushing noise is audible.

DIVERTER VALVE

Check valve by accelerating engine and allowing throttle to close rapidly; a momentary rush of air should be noted at diverter valve air outlet.

CHECK VALVE

To check operation of this valve, remove air supply hose from pump at check valve. With engine running, listen for exhaust leakage at check valve. A slight flutter of the valve at idle speed is normal.

AIR PUMP

Disconnect air output hose at air pump and with engine running, check that a flow of air is coming from pump outlet.

MAINTENANCE

At regular intervals complete system should be checked for proper operation. If air pump has a pressure relief valve located on pump housing, valve may be replaced. The centrifugal fan filter, if equipped, may be replaced. Anti-backfire valve, diverter valve, or check valve(s) are not serviceable and must be replaced as an assembly.

PRESSURE RELIEF VALVE

- 1) Valve may be replaced only if valve is mounted in pump housing. Remove pump and place on bench. Do not hold pump by clamping in vise. Using a steel bridge and a gear puller, valve may be removed.
- 2) Insert new valve into mounting hose. Place a block of wood over valve and tap with hammer until valve shoulders lightly in housing. If pressure plug is installed in new relief valve, remove this plug before installing valve. After valve is installed, install pressure plug.

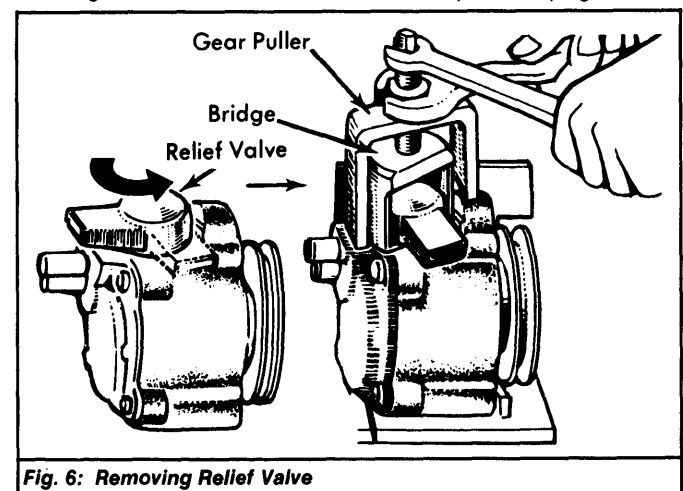
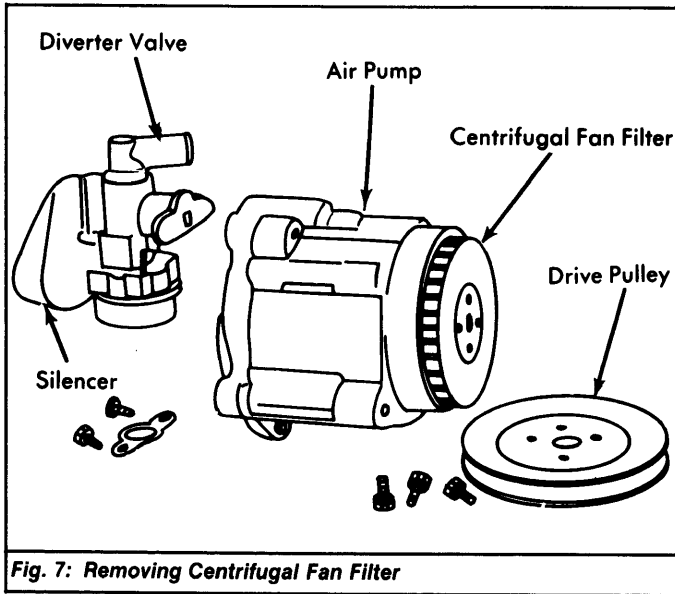

Fig. 6: Removing Relief Valve

1974-79 EXHAUST EMISSION SYSTEMS

Air Injection Systems (Cont.)

3-21



CENTRIFUGAL FAN FILTER

Remove drive belt, pulley mounting bolts and pulley. Break off remaining portions of centrifugal fan filter from pump hub being careful that fragments do not enter air intake hole. Install new filter by drawing it on with pulley and pulley bolts. Do not attempt to hammer or press filter on.

NOTE: After new filter is installed, it may squeal during operation until its outside diameter has worn in. This may require 20 to 30 miles of operation.

PUMP EXHAUST TUBE

Remove pump exhaust tube by placing tube in vise. With pliers, carefully pull tube with a twisting motion. Insert new tube into holes and tap in with a block of wood to protect tube. About 7/8" of tube should extend above pump.