

# 1974-79 FUEL SYSTEMS

## Bosch Diesel Fuel Injection – Audi & Volkswagen

**Audi: 1979 5000**

**Volkswagen: 1977-79 Dasher, Rabbit**

### SYSTEM SPECIFICATIONS

Application	Specification
Injection Nozzle Pressure .....	1700-1850 psi (123-130 kg/cm <sup>2</sup> )
Leakage Pressure .....	<sup>1</sup> 1564 psi (110 kg/cm <sup>2</sup> )
Injection Pump Timing .....	<sup>2</sup> .032" (0.83 mm)

- <sup>1</sup> – Pressure must hold for 10 seconds.  
<sup>2</sup> – Plunger stroke at engine TDC.

## DESCRIPTION

### INJECTION PUMP

Bosch distributor-type injection pump consists of a low-pressure, vane-type fuel pump, a high-pressure, plunger-type injection pump, speed governor, and injection timer. Pump features an electric on-off switch. High pressure is generated by a rotating plunger, which also distributes fuel to the 4 cylinders.

Vane-type fuel pump, roller ring, distributor plunger and mechanical, centrifugal governor are all powered by injection pump shaft. Injection timer on bottom of pump varies injection timing, as required by engine speed, increasing fuel pressure inside pump casing as engine speed increases.

This activates spring-loaded plunger in injection timer. Plunger rotates roller ring by means of driving pin. This has the effect of displacing its point of contact with eccentric disc, opposite pump's direction of rotation, and of advancing injection timing by 2.5 degrees.

### INJECTION NOZZLES

A pressurized mist of fuel is injected into a round swirl chamber. Fuel swirls around chamber, mixing with hot air, compressed at a 23:1 ratio. Combustion begins in rich swirl chamber, continues on through small passageway, and into leaner, main chamber. As peak cylinder pressures build in swirl chamber, rather than main chamber, loads on connecting rods and crankshaft are reduced.

### GLOW PLUGS

Fast, easy starting is assured by resistor-type glow plugs, installed in swirl chamber. Glow plugs have stubby-finger design rather than wire-type design used on many Diesel engines. See Fig. 3. Heat is applied to swirling fuel upon injection.

To start a cold engine, pull out cold start knob, located left of steering column. Turn ignition switch to pre-glow position. Some switches combine the on and pre-glow positions. Glow plug light on dash will come on.

When light goes out (approximately 15 seconds in warm climates; 60 seconds in cold), turn key to start position. After engine starts and runs for 2 minutes, push cold start knob fully inward. To stop engine, turn key to off position.

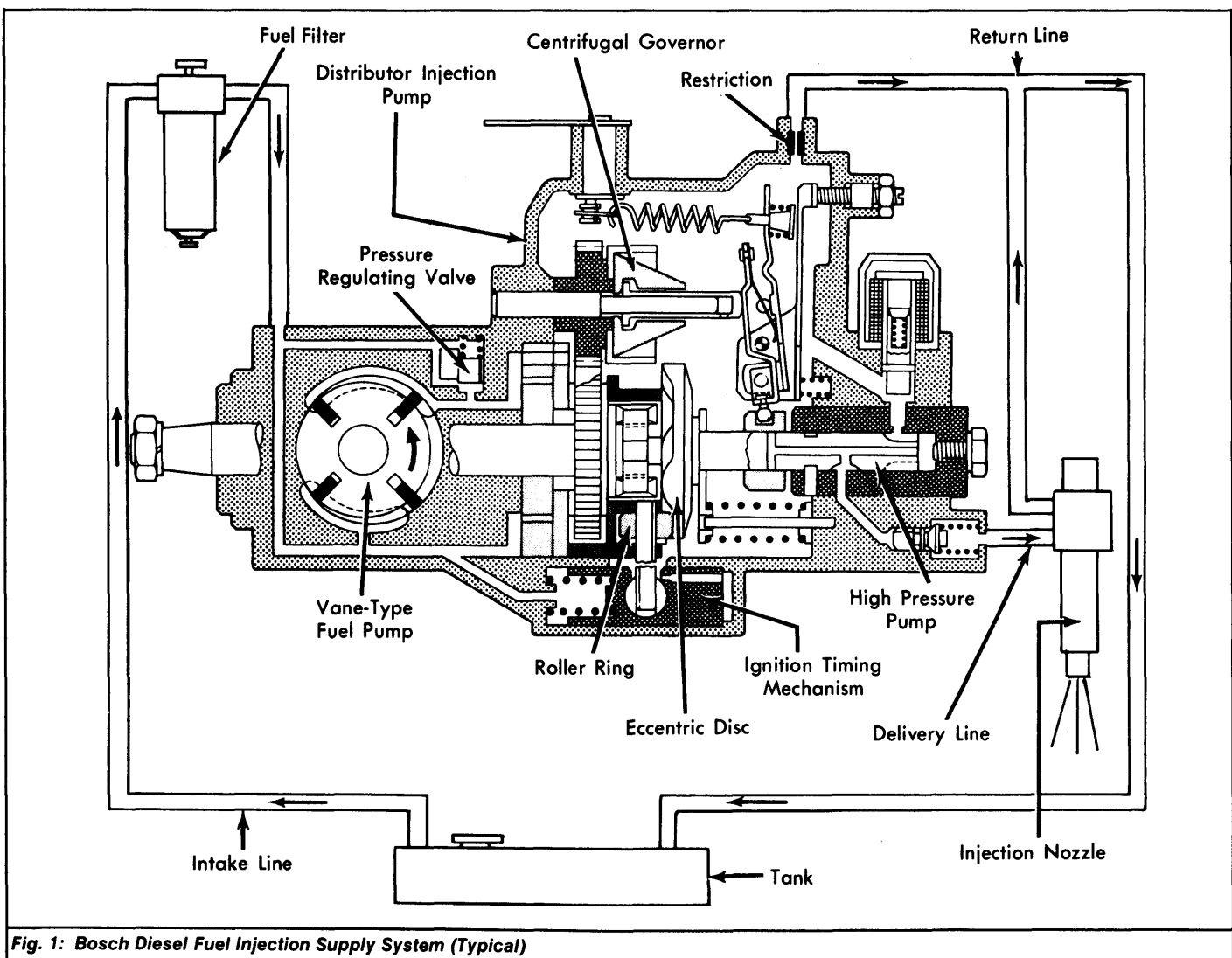


Fig. 1: Bosch Diesel Fuel Injection Supply System (Typical)

# 1974-79 FUEL SYSTEMS

## Bosch Diesel Fuel Injection – Audi & Volkswagen (Cont.)

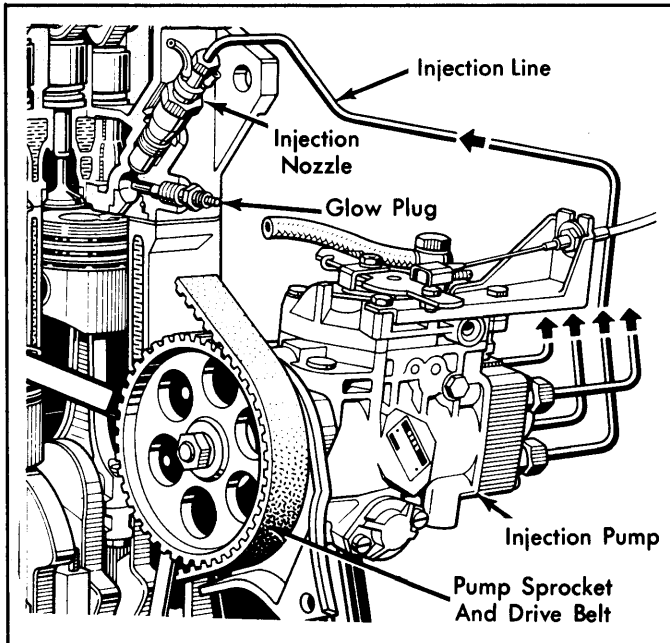


Fig. 2: Volkswagen Diesel Fuel System Components

**NOTE:** When temperature is below freezing, accelerator must be fully depressed during starting. Pre-glowing is not necessary if engine is already warm.

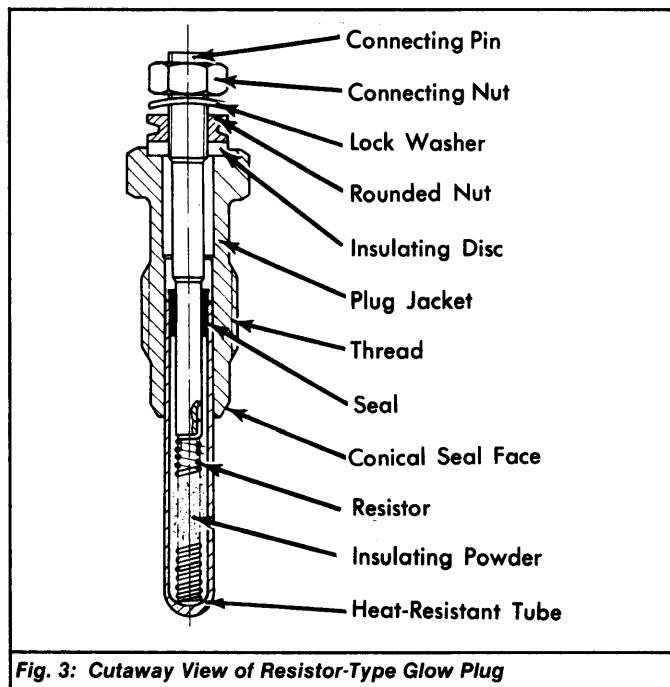


Fig. 3: Cutaway View of Resistor-Type Glow Plug

### SPEED GOVERNOR

A mechanical speed governor provides acceleration similar to a well-groomed spark ignition engine. Low speed range of modified part-load governor was expanded to also govern maximum engine speed. When operating at low speeds, governor assures smooth load absorption on starting.

Governor operates at starting, idling, and full-load ranges. At part-load speed range, governor has no effect, the injection pump being controlled directly by the accelerator. Operating range is determined by type of springs used and geometry of governor levers. See Fig. 4.

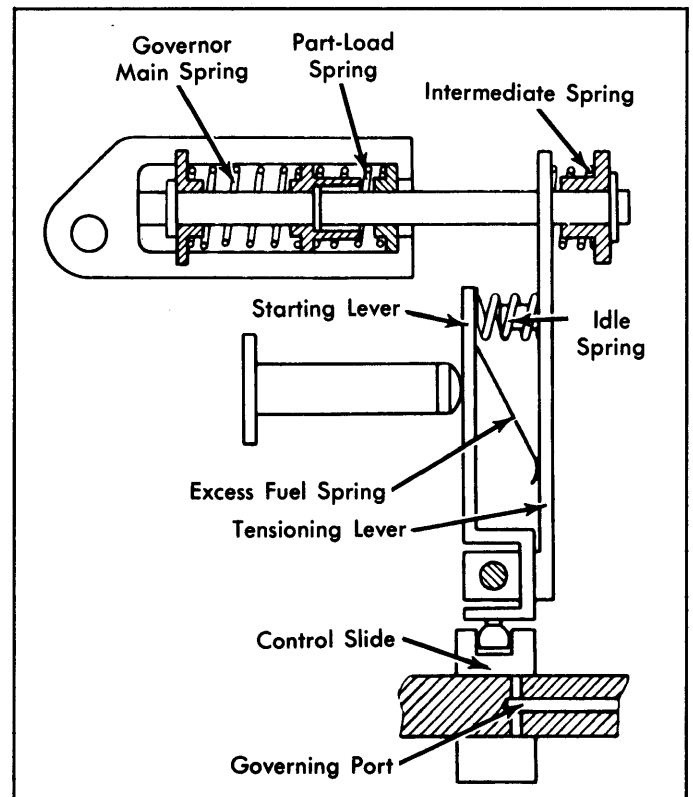


Fig. 4: Speed Governor Components

### FUEL FILTER

Early model fuel filters were equipped with hand primer pump and vent screw for bleeding fuel system. See Fig. 5. Later model filter has no primer pump. Regardless, which filter is used, bleeding is unnecessary. Vane-type fuel pump supplies fuel at starting speeds and is capable of automatically bleeding fuel supply system.

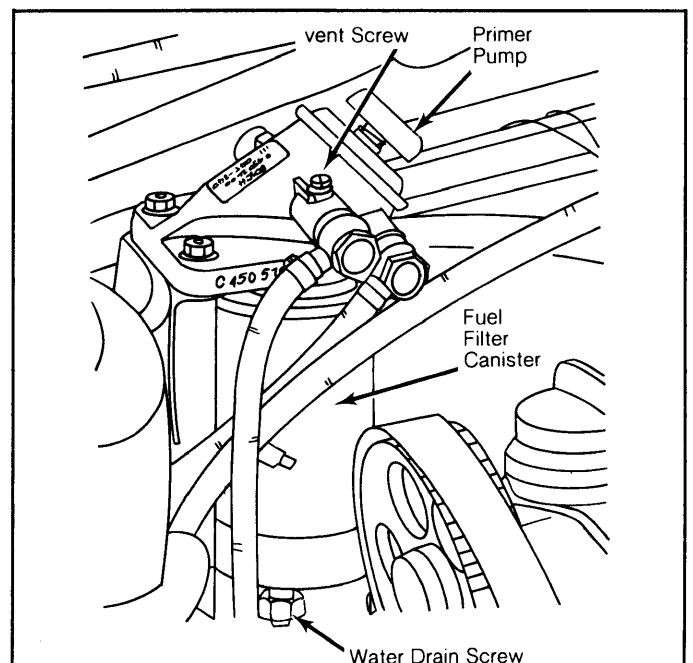


Fig. 5: Early Model Fuel Filter With Primer Pump

# 1974-79 FUEL SYSTEMS

## Bosch Diesel Fuel Injection – Audi & Volkswagen (Cont.)

### ADJUSTMENTS

#### ACCELERATOR CABLE

Be sure ball pin on pump lever is pointing upward and is in line with mark on edge of elongated hole. Accelerator cable should be attached at upper hole in bracket. Place pedal in full throttle position. Adjust cable with nuts until pump lever contacts stop free of strain.

#### COLD STARTING CABLE

Insert washer onto cable. Install cable into bracket with rubber bushing. Insert cable in pin and install lock washer. Move lever as far as possible in direction of arrow. Pull cable tight and secure pin with clamping screw.

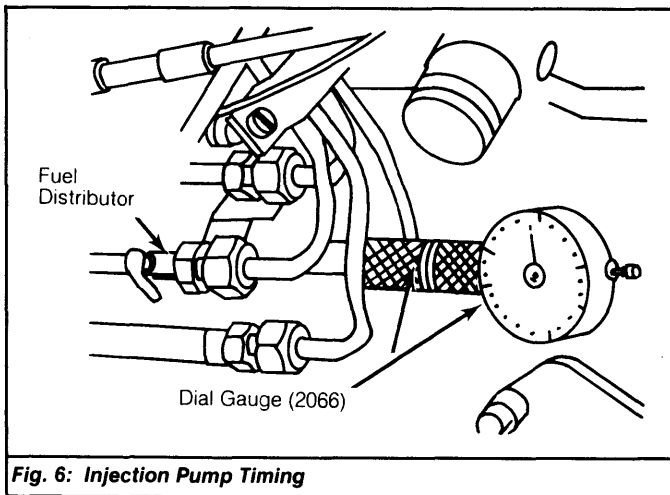
#### INJECTION PUMP TIMING

1) Turn engine until TDC mark on flywheel is in line with boss on bellhousing and the marks on pump and mounting plate are aligned. Remove plug from injection pump cover.

**NOTE: If engine is removed from vehicle, turn engine until TDC mark on flywheel aligns with end of Setting Bar (2068-A). On Audi, adjust setting bar to 125.5 mm position.**

2) Install adapter and Dial Gauge (2066) in plug hole. See Fig. 6. Preload gauge to .097" (2.5 mm). Turn engine counterclockwise (opposite normal rotation) until gauge needle stops moving.

3) Zero gauge with .039" (1 mm) preload. Turn engine clockwise (normal rotation) until TDC on flywheel is aligned with reference mark. Gauge should read .032" (0.83 mm). If necessary, loosen mounting plate and support bolts. Set lift to .032" (0.83 mm) by turning pump.



### TESTING

#### INJECTION NOZZLES

**CAUTION: Do not expose hands to injector spray during testing, as working pressure will cause fuel oil to penetrate skin.**

**Spray Formation Test** – Attach injection nozzle to Injector Tester (US 1111). Use long, slow strokes of testing pump lever (1-2 strokes per second). Spray should be even and stop cleanly.

**Noise Test** – Use short rapid strokes testing pump lever (4-6 strokes per second). If nozzle is working properly, it will "ping" as fuel emerges.

**Breaking Pressure Test** – Move pump lever down slowly. Note pressure at which injector releases fuel. If necessary, changing shims until working pressure reaches 1700-1850 psi (123-130 kg/cm<sup>2</sup>). A shim thickness of .0019" (0.05 mm) increases pressure by 71 psi (5.0 kg/cm<sup>2</sup>). Shims are available in thicknesses of .039-.070" (1.00-1.95 mm) in .0019" (0.05 mm) steps.

**Leakage Test** – Press pump lever down slowly and hold pressure at about 1564 psi (110 kg/cm<sup>2</sup>) for 15 seconds. No fuel should leak from nozzle tip.

#### GLOW PLUGS

1) Remove glow plug wire and bus bar connector. Connect test lamp to positive battery connector and touch test probe to each glow plug. If test lamp lights, glow plug is good. If not, glow plug is defective.

2) To check current supply to glow plug, reinstall wires and bus bar connector. Connect test lamp between glow plug of No. 4 cylinder and ground. Turn ignition switch to pre-glow position. Test lamp should light if current is present.

### REMOVAL & INSTALLATION

#### FUEL INJECTION PUMP

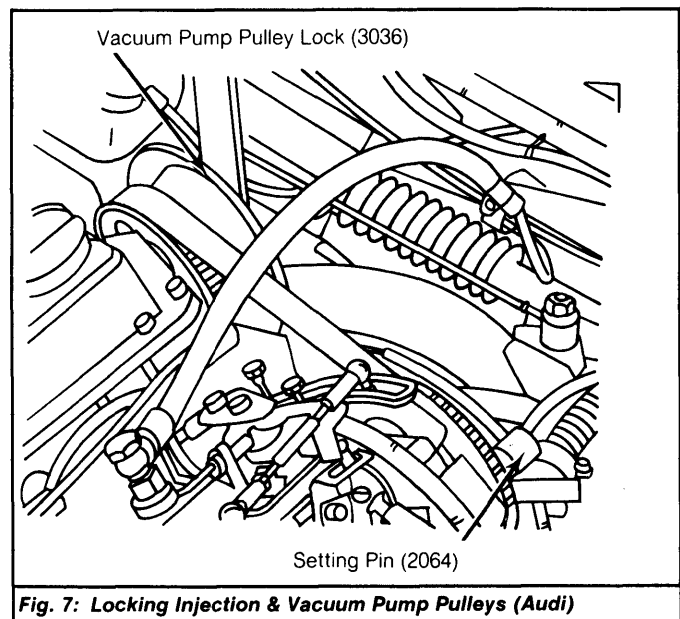
**NOTE: When working on injection system, keep all components clean. Clean all injection line unions before loosening.**

**Removal (Audi)** – 1) Remove cylinder head cover. Remove vacuum pump pulley and drive belt. Turn crankshaft to set No. 1 cylinder at TDC. Install Setting Pin (2064) to injection pump drive gear to lock pump.

2) Install Vacuum Pump Pulley Lock (3036) and remove pulley and injection pump drive belt. See Fig. 7. Loosen, but DO NOT remove, injection pump gear nut. Remove setting pin.

3) Install Gear Puller (3032). See Fig. 8. Be sure jaws of puller are at right angles to cross-bar and point in direction of spindle rotation. Carefully apply tension to puller. Using a light hammer, strike puller bolt lightly, until gear loosens from pump shaft taper.

4) Remove puller, nut, and gear. Remove all fuel lines from pump. Cover unions with clean cloth. Disconnect wire from stop control on pump and remove accelerator cable. Remove bolts from injection pump mounting plate. Support and remove pump.



**Installation** – 1) Install pump, aligning marks on pump and mounting plate. See Fig. 9. Install rear pump support and tighten mounting bolts to 18 ft. lbs. (24 N.m).

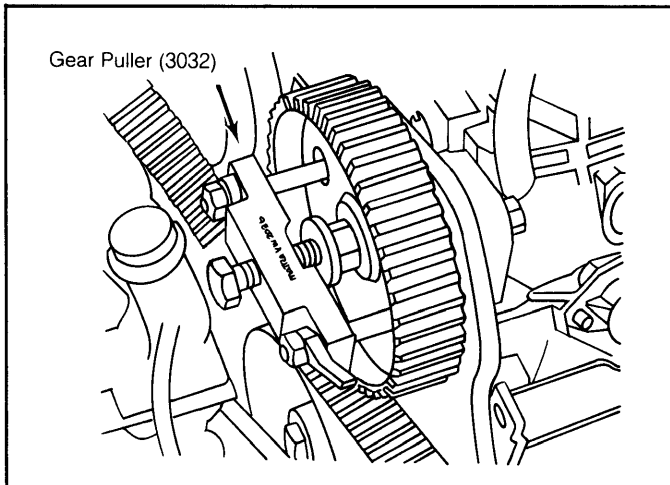
2) Install pump gear, turning it until marks on gear align with mounting plate mark. Lock pump with Setting Pin (2064) and tighten gear nut to 33 ft. lbs. (45 N.m).

3) Install camshaft Setting Bar (2065) to end of camshaft. See Fig. 10. Loosen cam gear bolt 1/2 turn and turn crankshaft until No. 1 cylinder TDC mark aligns with boss on clutch housing. Tighten cam drive gear to 33 ft. lbs. (45 N.m).

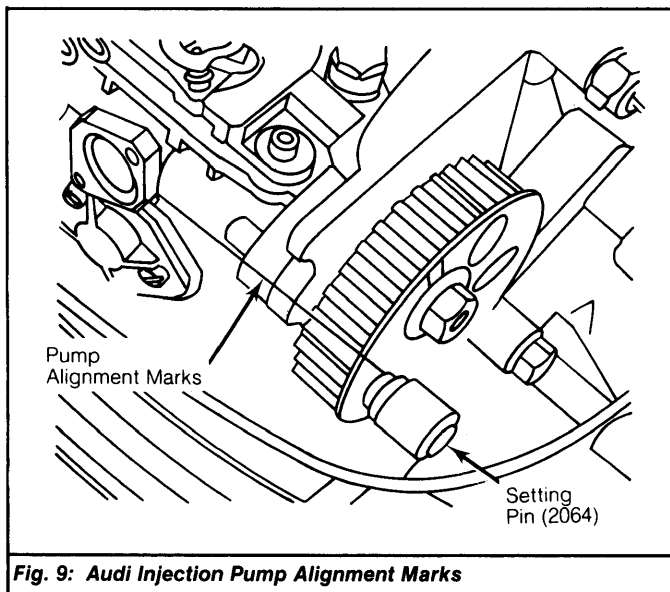
# 1974-79 FUEL SYSTEMS

## Bosch Diesel Fuel Injection – Audi & Volkswagen (Cont.)

- 4) Remove camshaft setting bar. Install injection pump drive sprocket and drive belt. Recheck timing mark alignment and tighten drive sprocket bolts with fingers.
- 5) Adjust belt tension by moving injection pump mounting plate away from camshaft. Tighten pump drive sprocket to 72 ft. lbs. (98 N.m). Remove setting pin, rotate crankshaft 2 full turns, recheck belt tension and injection pump timing.
- 6) Reinstall injection lines, drive belt cover and vacuum pump pulley and belt. Reinstall fuel supply and return lines, accelerator cable and wire for fuel shut-off solenoid.

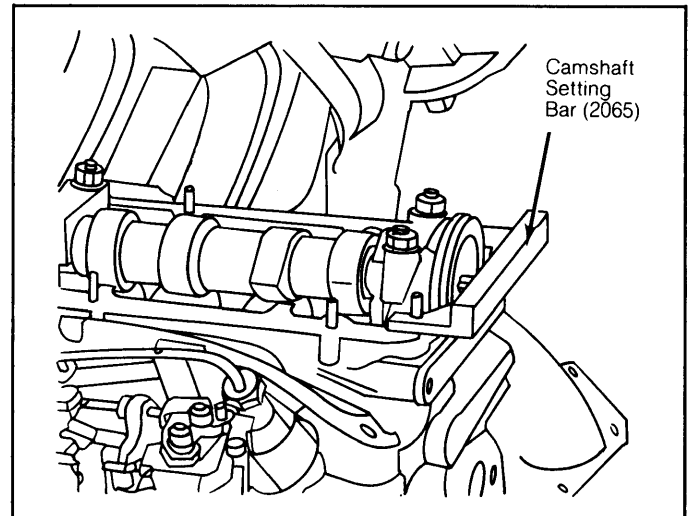


**Fig. 8: Injection Pump Gear Removal**



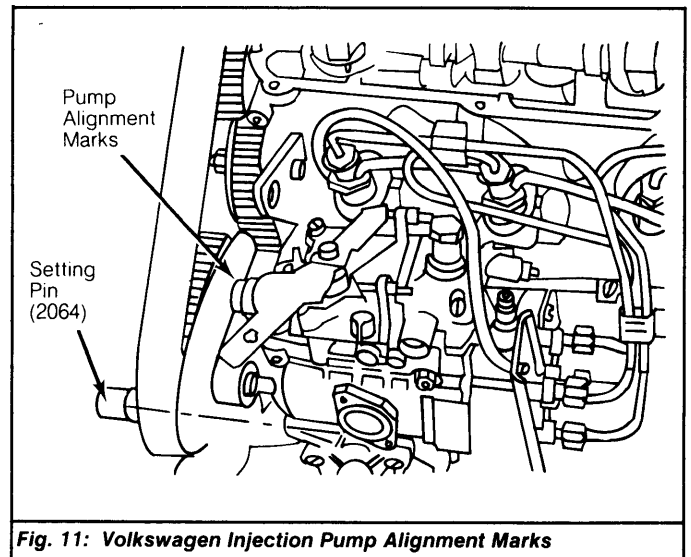
**Fig. 9: Audi Injection Pump Alignment Marks**

- Removal (Volkswagen) – 1)** Remove belt cover and cylinder head cover. Turn crankshaft to set No. 1 cylinder at TDC. Lock camshaft in position with camshaft Setting Bar (2065). See Fig. 10.
- 2)** Loosen, but DO NOT remove, injection pump gear nut. Install Gear Puller (3032). Be sure jaws of puller are at right angles to cross bar and point in direction of spindle rotation. Carefully apply tension to puller. Using a light hammer, strike puller bolt lightly, until gear loosens from pump shaft taper.
- 3)** Remove puller, nut, and gear. Remove all fuel lines from pump. Cover unions with clean cloth. Disconnect wire from stop control on pump and remove accelerator cable. Remove bolts from injection pump mounting plate. Support and remove pump.



**Fig. 10: Locking Camshaft For Injection Pump Installation**

- Installation – 1)** Install pump, aligning marks on pump and mounting plate. See Fig. 11. Tighten mounting bolts to 18 ft. lbs. (24 N.m). Install pump gear, turning it until marks on gear align with mounting plate mark. Lock pump with Setting Pin (2064) and tighten gear nut to 33 ft. lbs. (45 N.m).
- 2)** Install camshaft Setting Bar (2065) to end of camshaft. See Fig. 10. Loosen cam gear bolt 1/2 turn and turn crankshaft until No. 1 cylinder TDC mark aligns with boss on clutch housing. Install timing belt to injection pump. Tighten cam drive gear to 33 ft. lbs. (45 N.m).
- 3)** Remove camshaft setting bar. Adjust belt tension by removing setting pin and turning tensioner clockwise. Check tension between camshaft and pump gear with Belt Tension Gauge (VW 210). Scale should read 11-12.
- 4)** Turn crankshaft 2 turns in direction of normal engine rotation and recheck timing. Reinstall injection lines and drive belt cover. Reinstall fuel supply and return lines, accelerator cable and wire for fuel shut-off solenoid.



**Fig. 11: Volkswagen Injection Pump Alignment Marks**

# 1974-79 FUEL SYSTEMS

## Bosch Diesel Fuel Injection – Audi & Volkswagen (Cont.)

### INJECTION NOZZLES

**Removal & Installation** – 1) Detach injector line or lines. Use Injector Remover (US 2775) to remove injection nozzles. To disassemble injection nozzles, place upper part of nozzle in vise and loosen lower part.

2) To prevent parts from falling out, reverse position with lower of injector nozzle in vise. Carefully disassemble nozzle. Keep individual parts together. DO NOT interchange parts from one nozzle to another.

3) To reassemble and install, reverse removal procedure. Install heat shield with recess pointing upward. Tighten injection nozzles to 51 ft. lbs. (69 N.m) and fuel lines to 18 ft. lbs. (24 N.m).

### FUEL FILTER

**Removal & Installation** – 1) To replace filter, remove old canister and install new one. On early models, bleeding can be accomplished, if desired, by loosening vent screw on top of filter. See Fig. 5. Operate primer pump until fuel appears free of air bubbles. Then tighten vent screw and start engine.

2) If water is present in system, loosen vent screw and open water drain screw on bottom of filter. Operate primer pump until clean fuel appears. Tighten water drain screw. Operate primer pump again until fuel appears free of air bubbles at vent screw. Tighten vent screw.

---

**NOTE:** If engine will not start, loosen line unions on 2 injection nozzles. Crank engine without using glow plugs. When fuel appears at unions, tighten unions and start engine.

---

### TIGHTENING SPECIFICATIONS

Application	Ft. Lbs. (N.m)
Injection Pump Mounting Bolts .....	18 (24)
Fuel Injection Line Unions .....	18 (24)
Fuel Injection Pump Gear Nut .....	33 (45)
Camshaft Gear Bolt .....	33 (45)
Injection Nozzle-to-Socket .....	51 (69)
Nozzle (Upper-to-Lower Part) .....	51 (69)
Injection Pump Drive Gear .....	72 (98)