

# 1974-79 FUEL SYSTEMS

## Solex 34 PDSIT 2/3 1-Barrel Carburetors

Volkswagen: Type 2

### CARBURETOR IDENTIFICATION

#### CARBURETOR IDENTIFICATION NUMBERS

Application	Carburetor No.
Right Side .....	34 PDSIT-3
Left Side .....	34 PDSIT-2

### DESCRIPTION

Carburetor is a 1-barrel downdraft type with an automatic butterfly type choke. Lower part of carburetor houses float chambers, float, and all jets. Accelerator pump is of the diaphragm type and is located in-casting of float chamber.

The 34 PDSIT-2 and 34 PDSIT-3 carburetors are of a completely different design than those used on single carburetion engines. The left side carburetor incorporates a central idling system and mixture distributor tube that carries the idle mixture from idling system on left carburetor to the intake manifolds.

### ADJUSTMENTS

#### IDLE SPEED & MIXTURE

See appropriate TUNE-UP PROCEDURES article.

#### COLD (FAST) IDLE RPM

See appropriate TUNE-UP PROCEDURES article.

#### FLOAT LEVEL

1) Remove air horn and ensure fuel is at level predetermined by float level setting. Using depth gauge, measure distance from carburetor body surface level of fuel.

2) This measurement should be to specifications. If necessary, use different size gaskets under float needle seat to adjust float level. Gaskets come in .020" (.5 mm), .040" (1.0 mm), and .060" (1.5 mm) sizes.

**NOTE:** When float level adjustment procedure is performed on bench, it will be necessary to connect fuel line to inlet side of fuel bowl and fill fuel bowl until float level shuts off fuel.

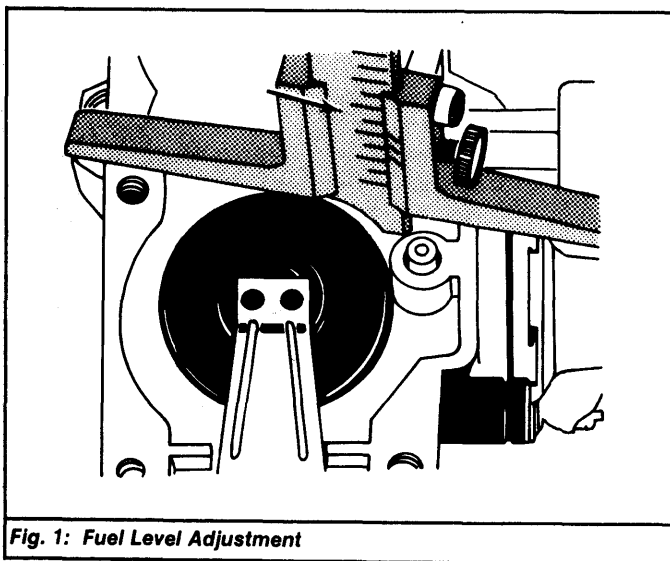

Fig. 1: Fuel Level Adjustment

#### THROTTLE VALVE SWITCH

**Automatic Transmission Equipped Models** - When throttle valve is open, vacuum from venturi, causes fuel to flow from float chamber into emulsion tube. Fuel in emulsion tube is converted into an air/fuel mixture and discharged into carburetor bore, through discharge arm. As engine speed increases air/fuel mixture increases.

### ACCELERATOR PUMP STROKE

**NOTE:** Automatic transmission models utilize thermostatic valve which varies quantity of injected fuel according to temperature of fuel in fuel bowl.

1) Ensure fuel bowl is full. Attach length of hose to accelerator pump discharge nozzle, so discharged fuel can be caught in graduated cylinder. Hold graduated cylinder lower than carburetor body and operate throttle valve 10 times. Average the amount of fuel injected per stroke.

2) On manual transmission equipped models, adjust fuel quantity by adjusting bellcrank on right-hand carburetor. On left-hand carburetor, insert cotter pin in different hole.

3) On automatic transmission equipped models, remove top of carburetor and insert thermometer into fuel bowl. If fuel temperature is below 70°F (21°C), quantity of fuel injected per stroke should be 1.5 cc per stroke.

4) If fuel temperature is above 70°F (21°C), injected quantity should be .7 cc per stroke. If necessary, turn threaded sleeve on end of accelerator pump actuating rod.

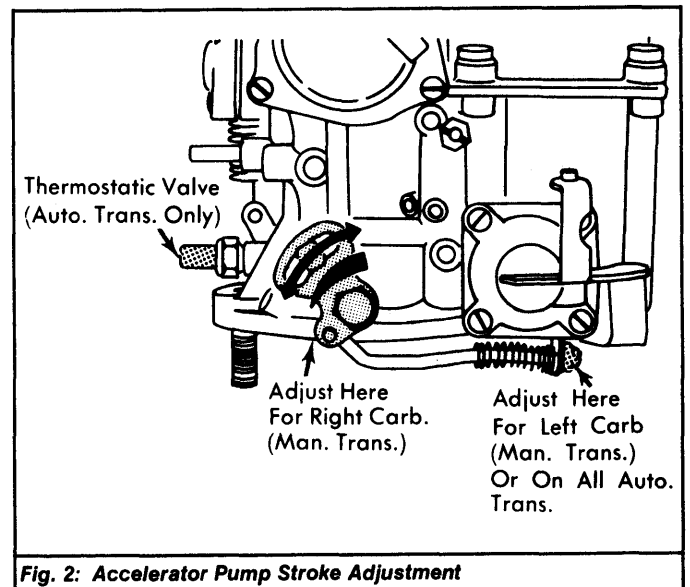

Fig. 2: Accelerator Pump Stroke Adjustment

#### DASHPOT

Check dashpot adjustment by depressing dashpot plunger and measuring gap between plunger and throttle lever. If gap is not .04" (1.0 mm), loosen lock nuts on either side of dashpot bracket and adjust to obtain specified gap.

#### SYNCHRONIZING CARBURETORS

1) On right-hand carburetor, disconnect throttle operating rod from throttle relay shaft by pulling lower ball socket off ball on relay shaft arm. On left-hand carburetor, turn synchronizing screw until right carburetor operating rod can be reconnected onto relay shaft arm without moving either carburetor throttle valve from its fully closed position.

2) Remove air cleaner ducts from top of both carburetors. Insert oil temperature gauge in place of dipstick. Start engine and run until normal operating temperature is reached.

3) Run engine at 2000-3000 RPM. Using airflow synchronizer check airflow at each carburetor. If airflow is unequal, adjust synchronizing screw to correct.

**NOTE:** Leave hoses attached to central idling system. Make sure both choke valves are fully open.

#### THROTTLE VALVE CLOSING GAP

With carburetor removed and choke valve closed, adjust both nuts on automatic choke connecting rod until .040" (10 mm) throttle valve gap is obtained. See Fig. 4.

# 1974-79 FUEL SYSTEMS

## Solex 34 PDSIT 2/3 1-Barrel Carburetors (Cont.)

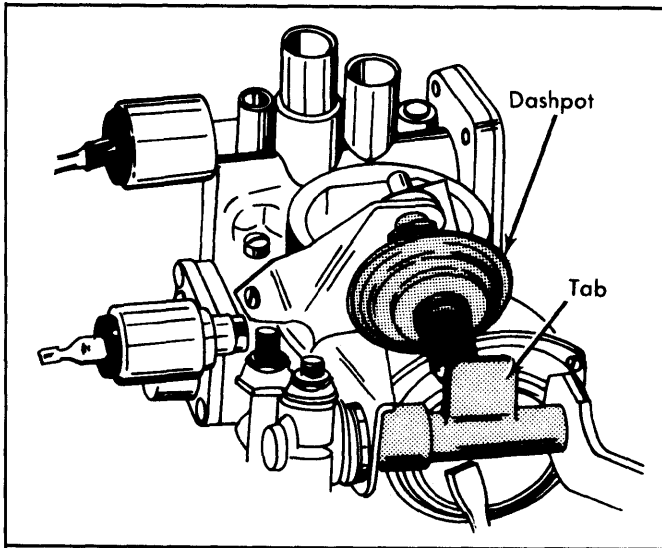

Fig. 3: Dashpot Adjustment

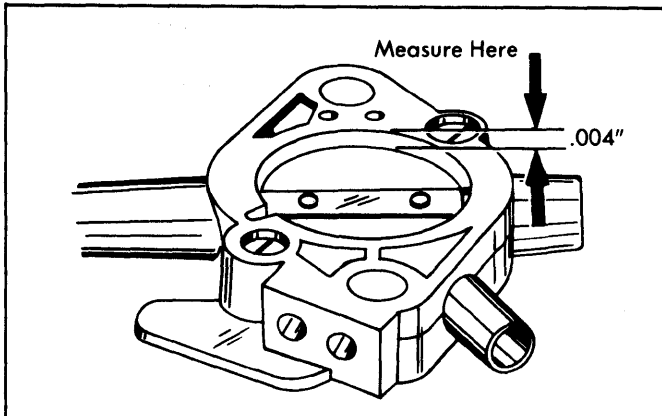

Fig. 4: Measuring Throttle Valve Closing Gap

### OVERHAUL

#### DISASSEMBLY

Remove carburetor upper part from body. Remove jets and adjustment screws from body. Remove float from carburetor upper body. See Fig. 5. Disassemble accelerator pump linkage. Remove throttle body from carburetor body. Disassemble throttle valve shaft assembly, automatic choke, and central idling system.

#### CLEANING & INSPECTION

Wash parts in carburetor cleaner (solvent). DO NOT soak any components containing rubber, leather, or plastic. Soak components long enough to thoroughly clean all surfaces and passages of foreign matter. Remove any residue after cleaning components in solvent. Blow out all fuel passages dry with compressed air. Inspect all parts for wear or damage and replace as necessary.

#### REASSEMBLY

To reassemble, reverse disassembly procedure. Install accelerator pump linkage in original hole in connecting link.

#### CARBURETOR SPECIFICATIONS

Application	34 PDSIT-2	34 PDSIT-3
Venturi Diameter	26 mm	26 mm
Main Jet	X130	X130
Air Correction Jet	175	175
Pilot Jet	52.5	52.5
Pilot Air Bleed	120	120
Auxiliary Fuel Jet	45	
Auxiliary Air Jet	0.7	
Needle Valve Gasket	.039" (1.0 mm)	.039" (1.0 mm)
Fuel Level	.5" (13 mm)	.5" (13 mm)
Throttle Valve Gap	.03" (.7 mm)	.03" (.7 mm)

# 1974-79 FUEL SYSTEMS

## Solex 34 PDSIT 2/3 1-Barrel Carburetor (Cont.)

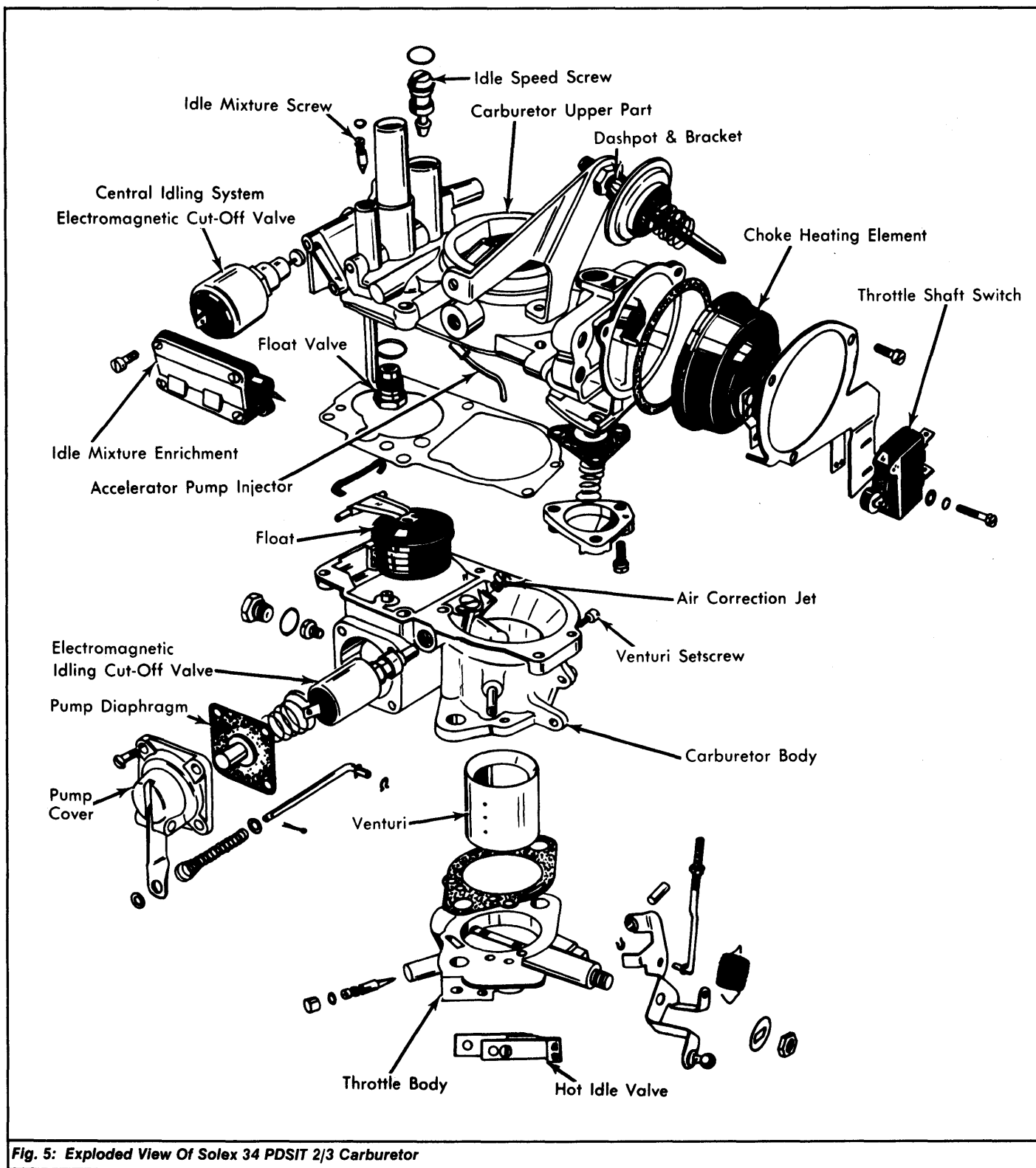

Fig. 5: Exploded View Of Solex 34 PDSIT 2/3 Carburetor