

1974-79 FUEL SYSTEMS

Motorcraft 4300 4-Barrel Carburetors

1974 Pantera

CARBURETOR IDENTIFICATION

Carburetor model designation and suffix are stamped on tag attached to carburetor by one air horn screw. First character on second line of tag indicates design changes which may affect parts replacement.

DESCRIPTION

Carburetor consists of air horn, main body, and throttle body. Fuel bowl is vented by an internal balance vent. On some models, a hot idle compensator is used. Main (primary) fuel system has booster type venturis cast into air horn and main venturis cast into main body.

Secondary throttle plates are mechanically operated from primary linkage. Secondary air valves are located above secondary venturis. Secondary fuel supply is controlled by metering rods which are attached to air valve plates.

Single fuel bowl supplies both primary and secondary fuel systems. Accelerator pump is piston type. Automatic choke is bimetal thermostatic spring with electric assist.

ADJUSTMENTS

IDLE SPEED & MIXTURE

See appropriate TUNE-UP PROCEDURES article.

COLD (FAST) IDLE RPM

See appropriate TUNE-UP PROCEDURES article.

FLOAT LEVEL

Float Level (Primary Fuel Valve) – 1) Fabricate float level gauge to dimensions shown. See Fig. 1. Adjust nuts on float level gauge for correct float level setting.

2) With air horn and float assembly removed and inverted, install float level gauge over floats with locating bolts installed in outboard holes of air horn. Both floats should just touch underside of float gauge bar.

3) Align floats by slightly twisting float arms. Adjust float height by bending primary needle tab (inner tab on float arm) up or down as required. See Fig. 2.

Auxiliary Fuel Valve – After adjusting primary fuel valve, check clearance between auxiliary fuel valve pin and tab on rear of float arm. If clearance is incorrect, adjust by bending tab up or down as required.

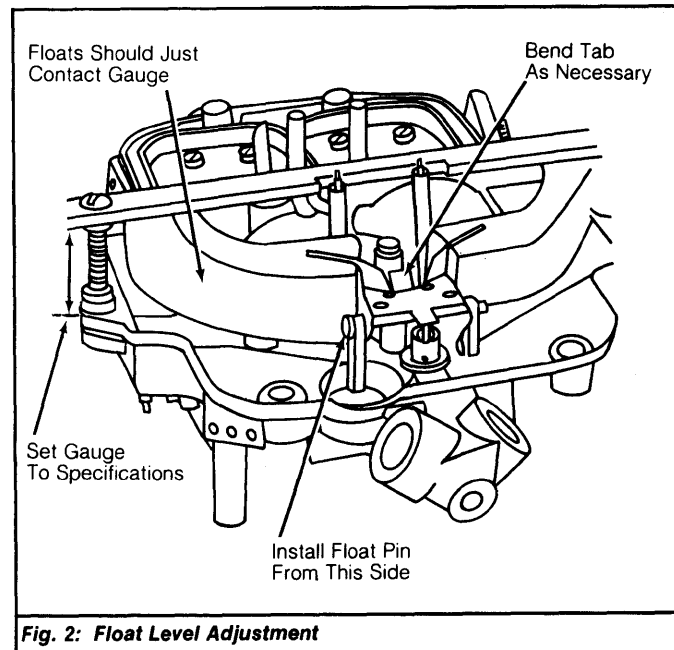
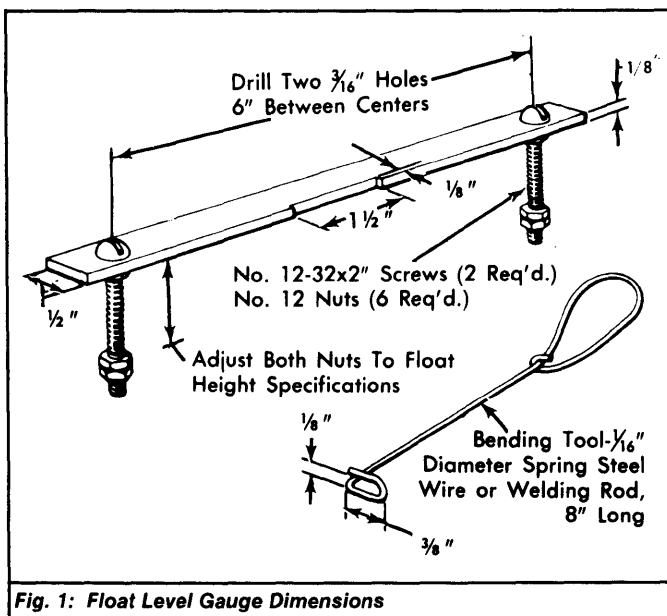

ACCELERATOR PUMP STROKE

Pump Stem Height – Measure pump stem height from air horn casting to top of accelerator pump stem as illustrated. Stem height should be .360-.040" (.91-1.02 mm). Height is adjusted by bending pump control rod.

Pump Linkage Adjustment – Disconnect pump rod from pump link before removing pump pivot pin. Line up holes in pump link and pivot hole in main body casting before attempting to reinstall pivot pin in correct hole. Make certain that split pin is spread to prevent it from dislodging.

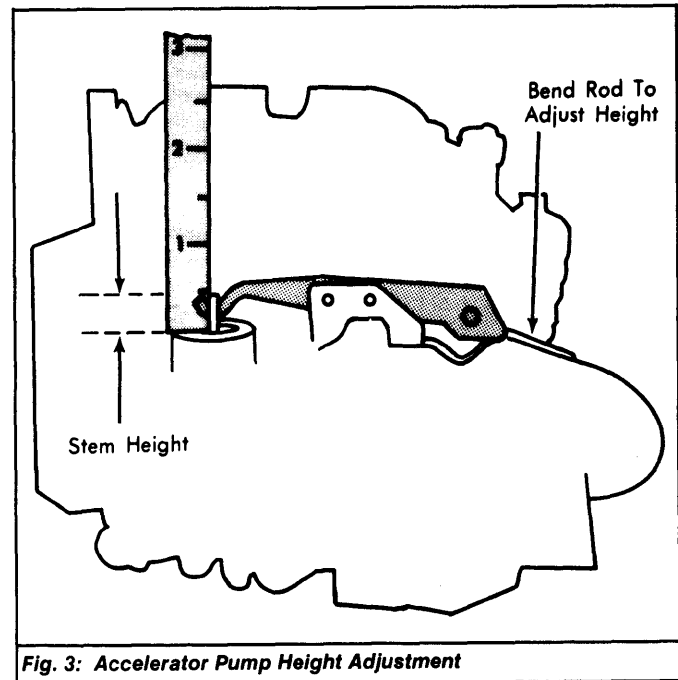

CHOKE VALVE PULL-DOWN

1) Remove thermostatic cover retainer, cover, and thermostatic spring. Bend a .036" (.91 mm) wire at a 90 degree angle, approximately $\frac{1}{8}$ " from end. Block throttle half open, so fast idle screw contacts fast idle cam.

1974 FUEL SYSTEMS

Motorcraft 4300 4-Barrel Carburetors (Cont.)

2-83

- 2) Insert bent end of gauge between piston slot and upper end of right-hand slot in choke housing. Maintain slight pressure on choke lever, to hold piston in place.
- 3) Use gauge or drill of correct size to check clearance between lower edge of choke valve and air horn wall. See Fig. 4. If adjustment is necessary, loosen hex head screw (left-hand thread) on choke valve shaft and pry link away from tapered choke shaft.
- 4) With a drill gauge of .010" (.25 mm) under specified clearance, inserted between lower edge of choke plate and air horn wall, hold choke against gauge with light pressure on choke lever.
- 5) With choke piston firmly against .036" (.91 mm) wire and choke valve against drill gauge, tighten hex head screw on choke valve shaft. Recheck choke valve pull-down using choke valve drill gauge of specified sized.

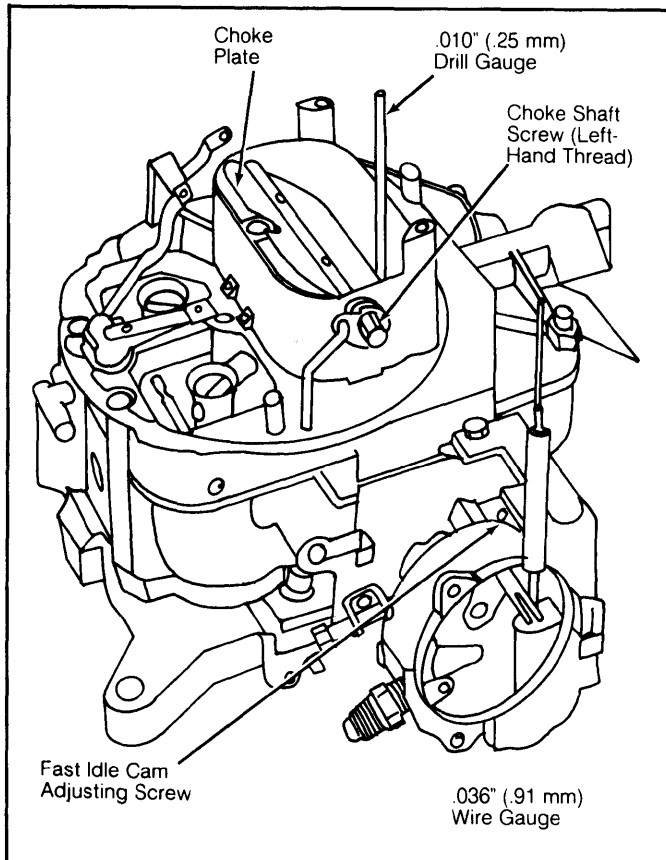

Fig. 4: Choke Plate Pull-Down Adjustment

FAST IDLE CAM CLEARANCE

- 1) Install choke cover and thermostatic coil loosely (make certain coil end engages choke lever slot). Rotate cover 90 degrees to rich position, then place fast idle speed screw on kickdown (center) step of the fast idle cam, against shoulder of the high step of cam, and hold it in this position.
- 2) Using a drill or gauge of correct size, check clearance between lower edge of choke valve and air horn wall. If fast idle cam clearance not correct, adjust by turning fast idle cam adjusting screw in or out as necessary. See Fig. 4.

AUTOMATIC CHOKE

Loosen choke cover retainer screws, rotate cover to align index mark on cover flange with correct graduation scale of housing. Tighten retainer screws.

CHOKE UNLOADER

- 1) Hold throttle valves in wide open throttle position, rotate choke valve toward closed position until pawl on fast idle lever contacts fast idle cam. See Fig. 5.
- 2) Use gauge or drill of specified size to check clearance between lower edge of choke valve and air horn wall. If this clearance not correct, adjust by bending pawl on fast idle speed lever forward or backward as required.

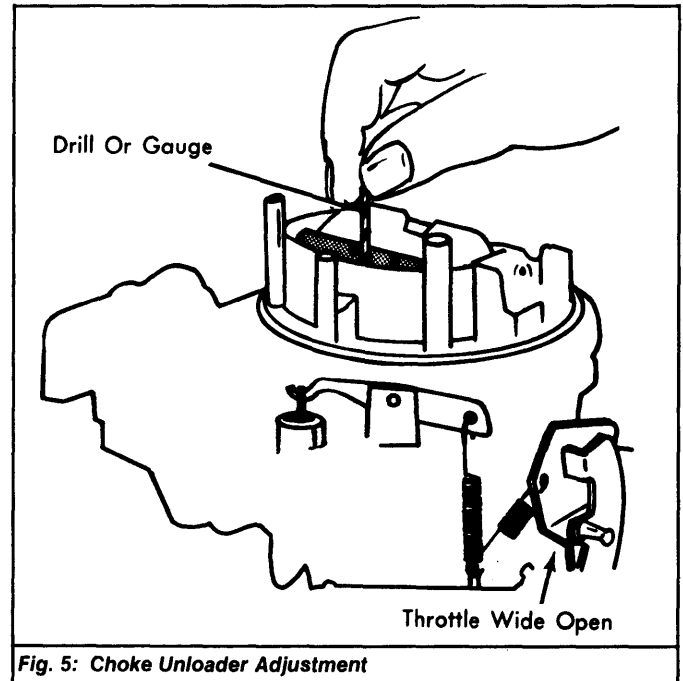

Fig. 5: Choke Unloader Adjustment

DASHPOT SETTING

With throttle valves closed at curb idle position, depress dashpot plunger fully and check clearance between dashpot plunger stem and throttle lever. If clearance is not to specifications, adjust by loosening lock nut and turning dashpot in or out.

OVERHAUL

DISASSEMBLY

- 1) To disassemble air horn, disconnect choke control rod from automatic choke lever and accelerating pump rod from throttle lever. Remove all air horn-to-main body retaining screws and carefully lift air horn off main body.
- 2) Remove float pivot pin and lift out float assembly. Remove main and auxiliary fuel inlet seat assemblies and gaskets. Disconnect secondary air valve lever rods from damper piston assembly and air valve. Remove damper piston and rod assembly.
- 3) If necessary to remove secondary air valves or shaft, scribe index mark on air valve housing and body casting. Remove valve retaining screws and valves, then slide shaft out of air horn.
- 4) If necessary to remove choke valve or shaft, remove staking marks on choke valve retaining screws or file off flared portion of screws. Remove retaining screws and valve, then slide shaft out of air horn.
- 5) Remove hot idle compensator valve assembly. DO NOT remove power valve vacuum valve assembly unless it is to be replaced. Remove staked areas and remove valve assembly carefully to avoid damage to air horn casting.
- 6) Invert main body assembly and catch accelerating pump discharge needle which will fall out. Use 3/8" deep socket to remove power valve. Remove main metering jets from within fuel bowl. See Fig. 6.

1974 FUEL SYSTEMS

Motorcraft 4300 4-Barrel Carburetor (Cont.)

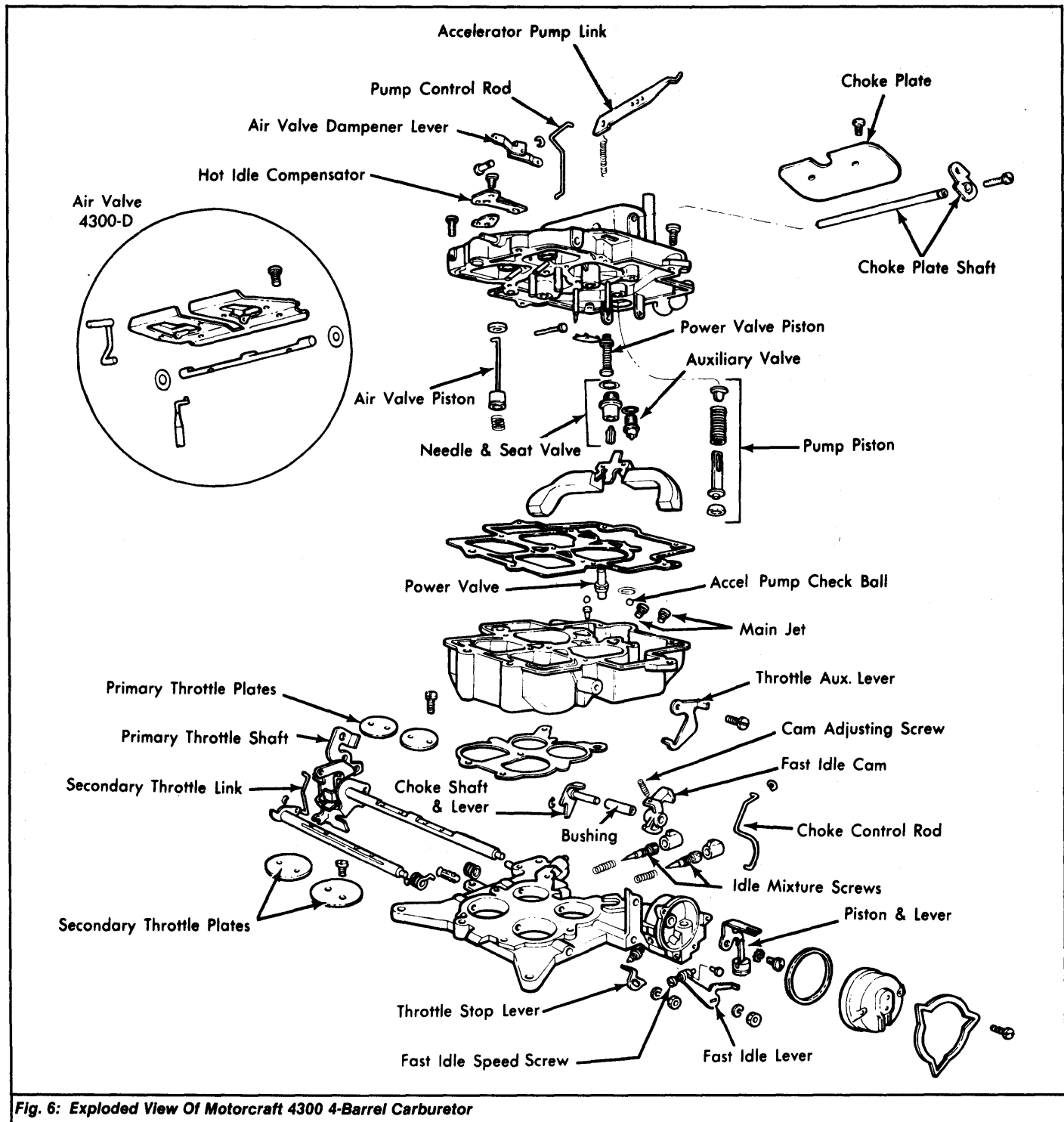

Fig. 6: Exploded View Of Motorcraft 4300 4-Barrel Carburetor

1974 FUEL SYSTEMS

Motorcraft 4300 4-Barrel Carburetors (Cont.)

7) Remove check ball retainer from bottom of accelerating pump cylinder with long nosed pliers, then invert main body and catch pump inlet ball check which will drop out. Remove throttle body screws and separate throttle body from main body.

8) From throttle body, remove automatic choke housing cover screws. Remove retainer, cover, gasket, and thermostatic spring assembly. Remove choke piston lever retaining screw, then remove piston assembly.

9) Remove secondary throttle-to-primary throttle lever connecting link. If necessary to remove primary or secondary throttle valves or shafts, remove staking marks on throttle valve attaching screws, remove screws and valves.

10) After valves are removed, remove nut from secondary throttle shaft. Slide shaft and return spring out of throttle body. Remove nut from primary throttle shaft, fast idle lever, and adjusting screw. Slide primary throttle shaft and lever assembly out of throttle body. Remove throttle lever assembly retainer, slide lever and springs off shaft.

11) If necessary to remove fast idle cam or bushings, press bushing out of choke housing and bushing column. DO NOT remove idle mixture limiter caps, screws, and springs.

NOTE: Housing and column must be properly supported during bushing removal and installation to prevent bending or breaking of the column.

CLEANING & INSPECTION

Wash parts in carburetor cleaner (solvent). DO NOT soak any components containing rubber, leather, or plastic. Soak components long enough to thoroughly clean all surfaces and passages of foreign matter. Remove any residue after cleaning components in solvent. Blow out all fuel passages dry with compressed air. Inspect all parts for wear or damage and replace as necessary.

NOTE: Do not remove calibrating shims from power valve piston rod for cleaning and use care not to distort rod.

REASSEMBLY

1) To reassemble, reverse disassembly procedure. During primary throttle valve installation, place return spring (coiled clockwise) on primary throttle shaft and insert shaft in throttle body.

2) Position throttle valves on shaft with ground flat edge of valves facing upwards and toward idle mixture needles, install valve screws just snug. Rotate shaft to closed position, tap valves lightly to properly seat them in throttle bore, then tighten valve screws securely.

3) During fast idle cam bushing installation, start bushing through choke housing. Position fast idle cam between housing and bushing column and slide bushing through fast idle cam, then support bushing column and press bushing into position in column. Clean bushing with 1/4" reamer before installing choke shaft and lever.

4) During choke valve installation, insert choke shaft in air horn with lever end on automatic choke side, install choke valve and tighten attaching screws just snug, then close valve and tap lightly to position it in air horn, tighten attaching screws and stake screws to prevent loosening.

5) Install a new seal on choke control rod, press seal into air horn and attach control rod to choke shaft lever. Seal must grip ledge in air horn at all four points to prevent unfiltered air entering carburetor.

6) During air valve installation, slide air valve shaft in air horn with slotted end of shaft in air valve spring chamber. Position plain air valve in air horn opening adjacent to spring chamber and tighten attaching screws just snug.

7) Install air valve in other air horn opening with control rod eye facing upward, install attaching screws just snug. Close air valves and tap valves lightly to position them in air horn, then tighten attaching screws and stake screws into place to prevent loosening.

CARBURETOR ADJUSTMENT SPECIFICATIONS									
Carb. No.	Idle Speed (Engine RPM)		Float Level		Choke Valve Pull-Down In. (mm)	Fast Idle Cam Clearance In. (mm)	Accel. Pump Setting In. (mm)	Unloader Setting In. (mm)	Auto. Choke Setting In. (mm)
	Hot	Fast	Primary In. (mm)	Auxiliary In. (mm)					
Pantera D4AE-AA	650±15	1250	3/4 (19.2)	1/16 (1.6)	.230 (5.9)	.200 (5.1)	#1	Index