

1974-79 FUEL SYSTEMS

Motorcraft 2150 2-Barrel Carburetors

Ford Motor Co: 1975-78 Capri (2800 cc)

CARBURETOR IDENTIFICATION

Carburetor number prefix and suffix (example D3ZF-EA) is stamped on tag attached to carburetor by one air horn screw. First character of second line on tag indicates design changes which may affect parts replacement.

1975 CARBURETOR IDENTIFICATION NUMBERS

Application	Man. Trans.	Auto. Trans.
2800cc		
Federal	D5ZE-AD	D5ZE-BD
Calif.	D5ZZ-CC	D5ZE-DC

1976 CARBURETOR IDENTIFICATION NUMBERS

Application	Man. Trans.	Auto. Trans.
2800cc		
Federal	75TF-AA	75TF-BA
Calif.	75TF-CA	75TF-DA

1977-78 CARBURETOR IDENTIFICATION NUMBERS

Application	Man. Trans.	Auto. Trans.
2800cc		
Federal	77TF-KA	77TF-LA
High Altitude	77TF-KA	77TF-LA

DESCRIPTION

Carburetors have 2 main assemblies, air horn and main body. Air horn serves as main body cover and contains choke plate and choke diaphragm. Throttle plate, accelerating pump, power valve and fuel bowl are in main body. Each bore contains main and boost venturis, main fuel discharge, accelerator pump discharge and throttle plate.

The boost venturis contain high speed bleed orifices and mechanical high speed bleed control system. This system consists of mechanical lift rod that actuates reverse tapered metering rods in high speed bleed jets. This system allows control of air/fuel mixture (to boost venturis) for more precise high speed operation and improved low speed response.

ADJUSTMENTS

IDLE SPEED & MIXTURE

See appropriate TUNE-UP PROCEDURES article.

COLD (FAST) IDLE RPM

See appropriate TUNE-UP PROCEDURES article.

ACCELERATOR PUMP STROKE

Check to be sure pump connecting rod is in inner hole (hole nearest carburetor body) of pump lever. Connecting rod should be in specified hole on lever. See Fig. 1.

FLOAT LEVEL

NOTE: Dry float setting is a preliminary adjustment only. Final adjustment (wet setting) must be made after carburetor is installed on engine.

Dry Setting - With air horn removed, depress float tab to seat fuel inlet needle. Measure distance from top of main body (gasket removed) to float, at point 1/8" from free end of toe. If adjustment is necessary, bend float tab. See Fig. 2.

Wet Setting - 1) With air horn and gasket installed temporarily on carburetor, idle engine for at least 3 minutes to stabilize fuel level in bowl. Remove air horn and gasket.

2) With engine idling, use "T" scale to measure from top machined surface of bowl to surface of fuel at a point at least 1/4" away from any vertical surface. See Fig. 3.

3) If fuel level not correct, stop engine and adjust by bending float tab toward or away from inlet needle as required. Repeat entire procedure to recheck fuel level. After adjustment is completed, install air horn and gasket and make necessary carburetor adjustments.

NOTE: Do not allow float tab to contact needle while making adjustment, as needle tip may be damaged.

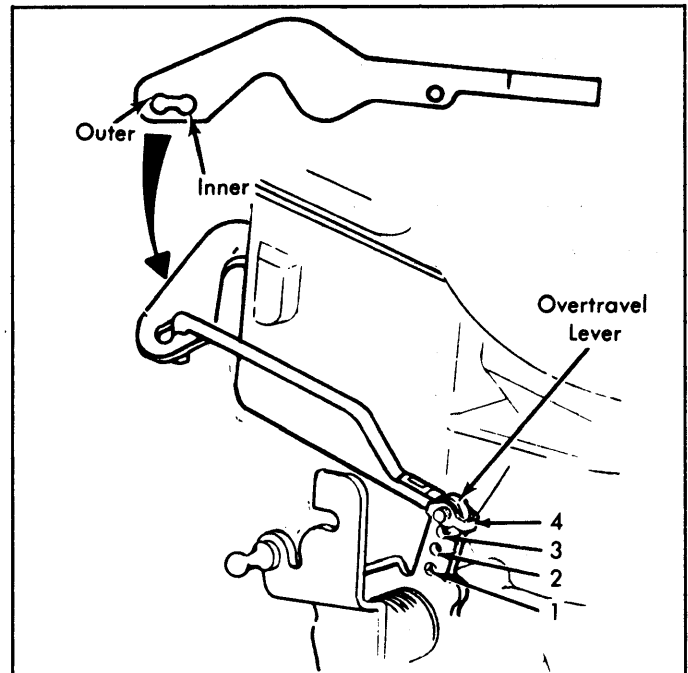

Fig. 1: Accelerator Pump Stroke Adjustment

CHOKE VALVE PULL-DOWN

1) With fast idle screw set on high step of fast idle cam, note index position of choke cover and loosen retaining screws. With retaining screws loose, rotate cover 90 degrees in rich direction and tighten screws.

2) Use outside vacuum source to seat diaphragm (or seat by hand). Insert specified gauge between lower edge of choke valve and air horn wall. If necessary, turn diaphragm adjusting screw located in end of diaphragm. Set choke to index position and tighten retaining screws.

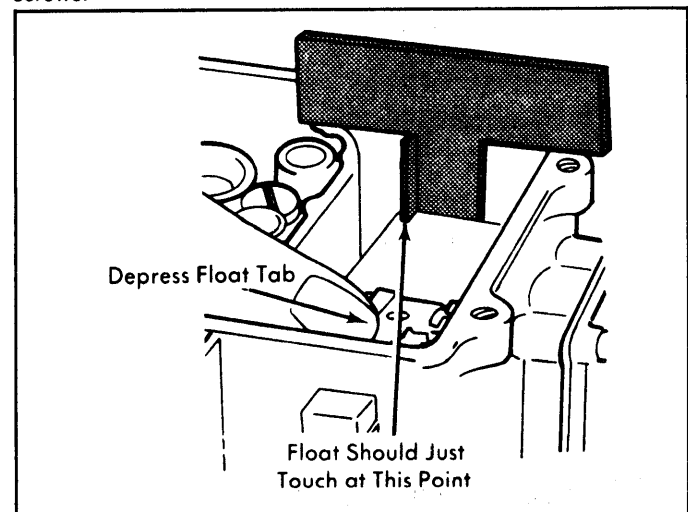

Fig. 2: Dry Fuel Level Adjustment

1974-79 FUEL SYSTEMS

Motorcraft 2150 2-Barrel Carburetors (Cont.)

AUTOMATIC CHOKE

Loosen choke cover retaining screws and rotate cover and thermostatic coil assembly in rich or lean direction to align reference mark on cover with correct graduation on housing. See Fig. 4. Index setting is with reference mark on cover aligned with longer center mark on housing.

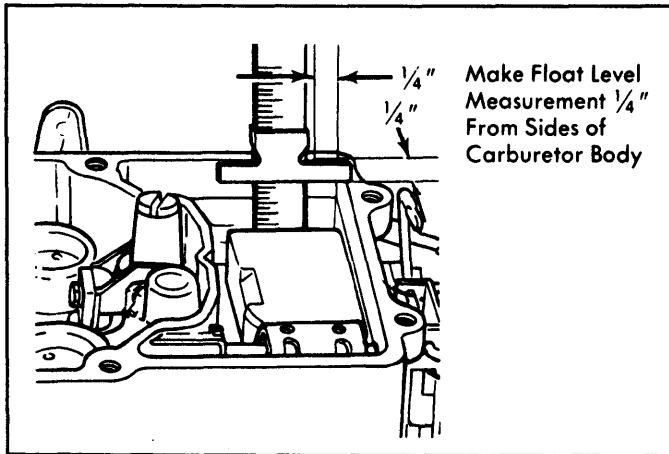

Fig. 3: Wet Fuel Level Adjustment

OVERHAUL

DISASSEMBLY

- 1) To disassemble air horn, remove air cleaner anchor screw and automatic choke rod retainer. Remove air horn attaching screws and lock washers. See Fig. 5.
- 2) Remove carburetor identification tag, air horn, and gasket. Remove choke control rod by loosening screw attaching choke shaft lever to choke shaft. Remove rod from air horn and slide plastic dust seal out of air horn.

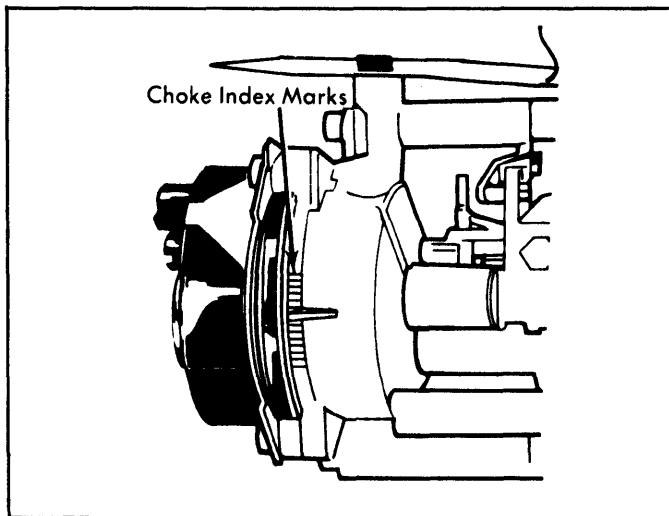

Fig. 4: Automatic Choke Adjustment

- 3) Remove choke diaphragm assembly, then if necessary to remove choke plate, remove staking marks on attaching screws and remove screws. Remove choke plate by sliding it out of shaft from top of air horn, then remove shaft from air horn.
- 4) From automatic choke, remove fast idle cam retainer. Remove thermostatic choke housing screws, clamp, housing, and gasket. Remove choke housing assembly, gasket, fast idle cam rod and cam lever. Remove choke lever screw, washer and lever assembly.
- 5) From main body, pry float shaft retainer from fuel inlet seat with screwdriver. Remove float, float shaft retainer, and fuel inlet needle assembly. Remove retainer and float shaft from float lever.

6) Remove fuel inlet needle, seat, filter screen and main jets. Remove booster venturi screw (accelerator pump discharge), air distribution plate, booster venturi and gasket. Invert main body and catch accelerator pump discharge weight and ball as they fall out.

7) Remove accelerator pump operating rod from over-travel lever and retainer by pressing the ends of the retainer together, while at the same time, pressing the rod away from the retainer until free. Remove rod and retainer.

8) Remove accelerator pump cover, diaphragm assembly and spring. If necessary to remove Elastomer valve, grasp firmly and pull it out. Elastomer valve must always be replaced whenever it has been removed from carburetor.

NOTE: If Elastomer valve tip breaks off during removal, don't forget to remove tip from fuel bowl.

9) Invert main body and remove power valve cover and gasket. Using a suitable wrench, remove power valve and remove gasket. Remove idle fuel mixture adjusting needles and springs.

10) If necessary, remove nut and washer securing fast idle adjusting lever assembly to throttle shaft and lift off lever assembly. Remove anti-stall dashpot or solenoid.

11) If throttle plates are to be removed, scribe plates along shaft and mark each plate to match its original location (which bore) for reassembly. Slide throttle shaft from main body.

CLEANING & INSPECTION

Wash parts in carburetor cleaner (solvent). DO NOT soak any components containing rubber, leather, or plastic. Soak components long enough to thoroughly clean all surfaces and passages of foreign matter. Remove any residue after cleaning components in solvent. Blow out all fuel passages dry with compressed air. Inspect all parts for wear or damage and replace as necessary.

REASSEMBLY

- 1) To reassemble, reverse disassembly procedure. During throttle valve installation, refer to scribe marks made at disassembly. Install throttle valves with attaching screws snug.
- 2) Close valves and check fit by holding assembly up to a light. Little or no light should show between valve edges and bore. Top valves lightly to centralize, then tighten and stake screws securely while supporting shaft on metal bar.
- 3) Install choke valve with attaching screws snug. Check valve fit and free movement by moving valve from closed to open position. Binding can be corrected by grinding edge of valve. Tighten screws securely while holding valve closed. Stake screws while supporting with a metal bar.
- 4) For choke valve rod and seal installation, assemble choke rod seal between two brass washers. Slide into position on seal retainer. Insert choke rod through seal and air horn to engage choke shaft lever clevis nut.
- 5) Lubricate tip of new Elastomer valve and insert valve tip in center hole in pump cavity. Use needle nosed pliers inserted in fuel bowl to pull valve in until it is fully seated. Cut off valve tip at retaining shoulder and remove tip from fuel bowl.
- 6) Position accelerator pump return spring on boss in pump chamber. Assemble diaphragm and cover and install two cover screws that do not retain vent valve bracket. Insert a new plug in vent rod and install vent rod and bracket assembly on pump.
- 7) Install idle mixture screws until lightly seated, then back out 1 1/2 turns for initial adjustment. Position power valve cover so that limiter stops are in position to provide positive stops for tabs on idle mixture screw limiter caps.

1974-79 FUEL SYSTEMS

Motorcraft 2150 2-Barrel Carburetor (Cont.)

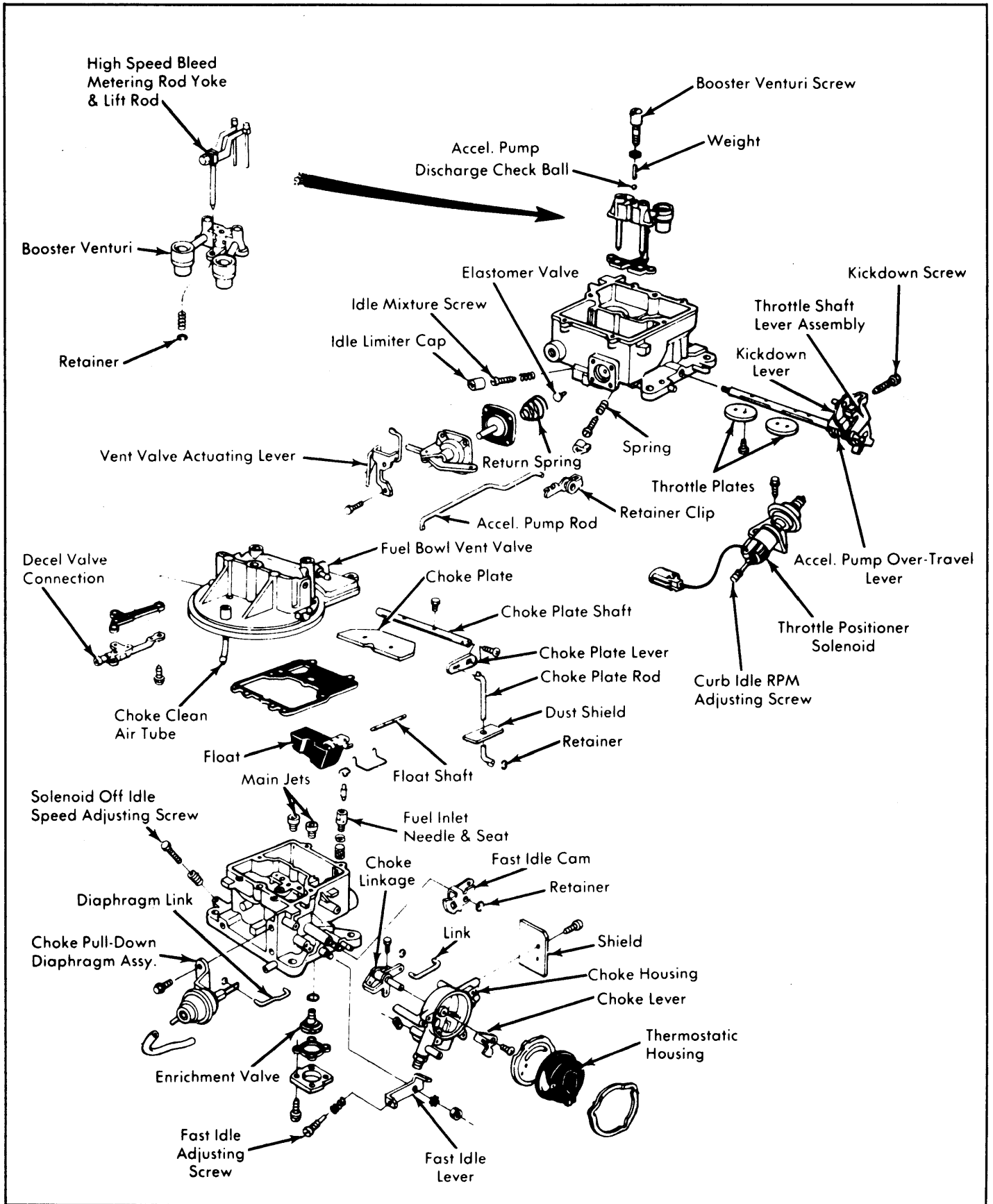

Fig. 5: Exploded View of Motorcraft 2150 2-Barrel Carburetor

1974-79 FUEL SYSTEMS

Motorcraft 2150 2-Barrel Carburetors (Cont.)

1975 CARBURETOR ADJUSTMENT SPECIFICATIONS									
Carb. Number	Idle Speed (Engine RPM)		Float Setting		Accelerator Pump Setting		Initial Choke Pull-Down Clearance	Fast Idle Cam Linkage Clearance	Auto. Choke Setting
	Hot	Fast	Wet	Dry	Overtravel Lever	Pump Lever			
Ford D5ZE-DC	①	①	¾"	⅜"	2145"	2 NR

① -- See Engine Compartment Emission Control Tune-Up Decal.

1976 CARBURETOR ADJUSTMENT SPECIFICATIONS									
Carb. Number	Idle Speed (Engine RPM)		Float Setting		Accelerator Pump Setting		Initial Choke Pull-Down Clearance In. (mm)	Fast Idle Cam Linkage Clearance In. (mm)	Auto. Choke Setting
	Hot	Fast	Wet In. (mm)	Dry In. (mm)	Overtravel Lever	Pump Lever			
75TF-AA	①	①	.750 (19)	.375 (9.5)	2	②	.100 (2.5)	.120 (3.0)	3R
75TF-BA	①	①	.750 (19)	.375 (9.5)	2	②	.100 (2.5)	.120 (3.0)	3R
75TF-CA	①	①	.750 (19)	.375 (9.5)	2	②	.110 (2.8)	.130 (3.3)	3R
75TF-DA	①	①	.750 (19)	.375 (9.5)	2	3	.110 (2.8)	.130 (3.3)	3R

① -- See Emission Control Tune-Up Decal.

② -- Pump lever inner hole.