

1974-79 TUNE-UP PROCEDURES

Volvo 4-Cylinder

140 Series, 240 Series

ENGINE IDENTIFICATION

Engine identification code is stamped on left side of engine block. Engine codes are also found on model plate, located on right front suspension strut mounting.

1977-78 ENGINE CODES

Application	Code
Federal	453, 459
Calif.	459

1979 ENGINE CODES

Application	Code
Federal	
Man. Trans.	498 780
Auto. Trans.	498 781
Calif.	
Man. Trans.	498 782
Auto. Trans.	498 782

MODEL IDENTIFICATION

VEHICLE IDENTIFICATION NUMBER

Vehicle Identification Number is located on a plate attached to left windshield pillar. Number also appears on model plate, located on right front suspension strut mounting.

ENGINE COMPRESSION

Warm engine to normal operating temperature. Check compression with spark plugs removed, throttle valve wide open, and engine cranking at 250-300 RPM.

COMPRESSION PRESSURE SPECIFICATIONS

Application	Pressure
All Models	128-156 psi (9-11 kg/cm ²)

VALVE CLEARANCE

1) Valve clearance is adjusted with engine hot or cold. Remove valve cover. Turn crankshaft center bolt until camshaft is in position for firing cylinder No. 1. Both cam lobes should point up at equally large angles. Pulley timing mark should be at TDC.

2) Check valve clearance of cylinder No. 1, using a feeler gauge between camshaft lobe and adjusting discs. If clearances are incorrect, change thickness of adjustment discs. Discs are available from .130" (3.30 mm) to .178" (4.50 mm) in .002" (.05 mm) increments

3) After valves for No. 1 cylinder are properly adjusted, rotate crankshaft to firing position of cylinders No. 3, 4, and 2 in sequence and complete adjustment.

VALVE CLEARANCE SPECIFICATIONS

Application	Cold In. (mm)	Hot In. (mm)
Checking012-.018 (.30-.45)	.014-.020 (.35-.50)
Setting014-.016 (.35-.40)	.016-.018 (.40-.45)

VALVE ARRANGEMENT

1974-76 Models

E-I-I-E-E-I-I-E - Front-to-rear.

1977-79 Models

E-I-E-I-E-I-E-I - Front-to-rear.

SPARK PLUGS

SPARK PLUG SPECIFICATIONS

Application	Specification
Gap028-.032" (.7-.8 mm)
Torque	
1975-78 Models	25-29 ft. lbs. (34-39 N.m)
1979 Models	15-18 ft. lbs. (20-24 N.m)

SPARK PLUG TYPE

Application	Bosch No.
1974 Models	W200T35
1975-79 Models	W175T30

DISTRIBUTOR

Models are equipped Bosch single-point distributors or Bosch electronic ignition system.

DISTRIBUTOR SPECIFICATIONS

Application	Specification
Point Gap014" (.35 mm)
Dwell Angle	59-65°
Breaker Arm Spring Tension	18-21 ozs. (500-600 g)

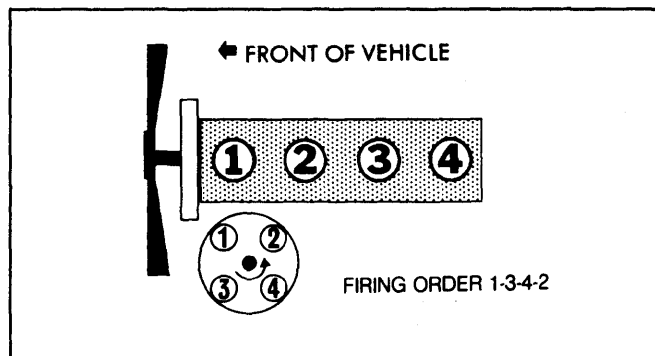

Fig. 1: 1974-76 Model Firing Order & Distributor Rotation

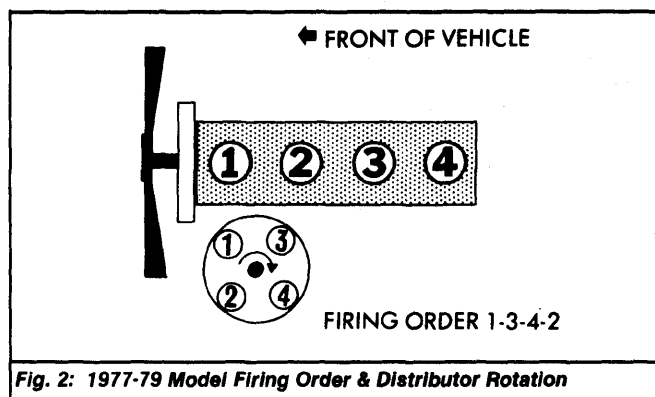

Fig. 2: 1977-79 Model Firing Order & Distributor Rotation

IGNITION TIMING

1974-75 Models - Warm engine to normal operating temperature. Check or adjust ignition timing with engine idling at specified RPM and distributor vacuum hose disconnected.

1976-78 Models - Adjust throttle linkage and micro switch (if equipped). See THROTTLE LINKAGE & MICRO SWITCH in this article. Disconnect and plug vacuum hose at distributor. Set idle speed and ignition timing to specifications. Reconnect distributor vacuum hose.

1974-79 TUNE-UP PROCEDURES

Volvo 4-Cylinder (Cont.)

1979 Models - Connect timing light and tachometer to engine. On Federal models, disconnect and plug distributor vacuum hose at distributor. On all models, use idle air adjusting screw to set idle speed to specified RPM. Rotate distributor to set timing to specifications. Reconnect distributor vacuum hose.

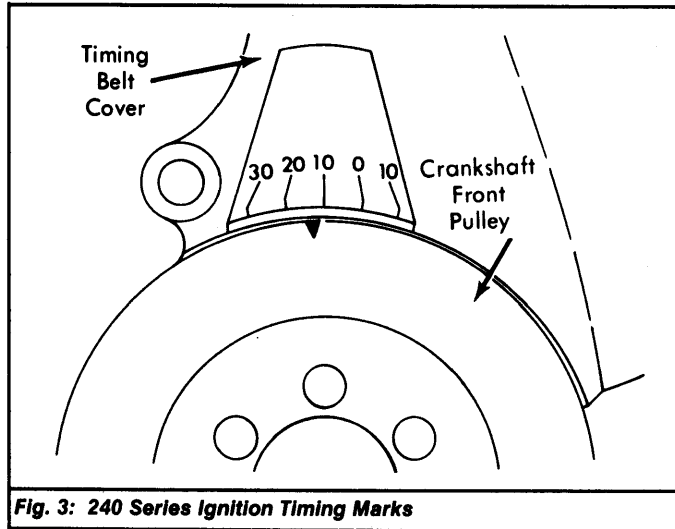

Fig. 3: 240 Series Ignition Timing Marks

IGNITION TIMING SPECIFICATIONS

Application	RPM	Timing
1974 Models	600-800	10°BTDC
1975 Models	700	5°BTDC
1976 Models	700-800	15°BTDC
1977-78 Models	700-800	12°BTDC
1979 Models		
Federal	700-800	¹ 10°BTDC
Calif.	700-800	8°BTDC

¹ - With distributor vacuum hose disconnected and plugged.

IDLE SPEED & MIXTURE

1974-75 Models - 1) Warm engine to normal operating temperature. Attach exhaust gas analyzer to exhaust pipe fitting just in front of catalytic converter. Turn idle speed screw to obtain specified idle RPM. 2) Disconnect air injection (if equipped). Using Wrench (999 5015), adjust CO% level to specifications by turning mixture adjustment screw. Recheck idle RPM and adjust if necessary.

1974-77 IDLE SPEED & CO% LEVEL SPECIFICATIONS

Application	RPM	¹ CO%
1974-76 Models		
Man. Trans.	900	1.5-2.0
Auto. Trans.	800	1.5-2.0
1977 Models		
Federal		
Man. Trans.	850-950	1.2-1.8
Auto. Trans.	750-850	1.2-1.8
Calif.	850-950	1.2-1.8

1976-78 Models - Adjust throttle linkage and micro switch (if equipped). See THROTTLE LINKAGE & MICRO SWITCH in this article. Turn idle adjusting screw until idle speed is to specifications. Disconnect oxygen sensor lead (if equipped) and adjust CO% level. Reconnect oxygen sensor lead. Recheck idle RPM and adjust if necessary.

1979 Models - 1) Warm engine to normal operating temperature. Attach exhaust gas analyzer to exhaust pipe fitting just in front of catalytic converter. Turn idle air adjusting screw to obtain specified idle RPM.

2) Disconnect oxygen sensor lead (if equipped). Remove rubber plug from mixture control unit. Insert mixture adjuster into control unit and adjust CO% level. Reconnect oxygen sensor lead. Recheck idle RPM and adjust if necessary.

1978-79 IDLE SPEED & CO% LEVEL SPECIFICATIONS

Application	RPM	¹ CO%
1978 Models		
Federal		
Man. Trans.	850-950	0.7-1.3
Auto. Trans.	750-850	0.7-1.3
Calif.	850-950	1.0-2.5
1979 Models		
Federal	850-950	² 0.7-1.3
Calif.	850-950	1.0-2.5

¹ - With oxygen sensor disconnected (if equipped). When sensor is reconnected, reading should drop below one percent.

² - On oxygen sensor equipped 242GT, set mixture to 1.0-2.5 percent.

THROTTLE LINKAGE & MICRO SWITCH

1976-78 Models - 1) Warm engine to normal operating temperature. Connect tachometer and timing light to engine. Disconnect and plug air hose at air pump. Disconnect and plug vacuum hose at EGR valve.

2) Disconnect throttle link and cable at throttle pulley. Loosen lock nut and screw out throttle shaft adjusting screw. Turn screw in until it just touches boss, then turn screw one additional turn.

3) Lock screw into place and check that throttle valve does not bind. Ensure that throttle control linkage, from pulley to lever ball, can be attached to lever ball without changing pulley position.

4) Attach throttle cable to pulley. Adjust cable sheath so that cable is snug but does not change pulley position. Depress throttle completely, pulley should touch the full throttle boss.

5) Adjust automatic transmission cable so that cable clip will travel 2" (51 mm) from idle position to full throttle position. At idle there should be .040" (1 mm) clearance between clip and adjusting sheath.

6) On California models, connect test light to micro switch and turn ignition on. Place a .060" (1.5 mm) feeler gauge between throttle screw and boss. Test light should be on. Insert a .080" (2 mm) feeler gauge between throttle screw and boss. Test light should go out.

7) If not, place the .060" (1.5 mm) feeler gauge between throttle screw and boss. Loosen lock nut and screw out micro switch adjusting screw until test light goes out.

8) Turn adjusting screw in until a click is heard from micro switch and test light comes on. Tighten lock nut, disconnect test light, and remove feeler gauge.

FUEL PUMP

FUEL PUMP SPECIFICATIONS

Application	Specification
Pressure	64-74 psi (4.5-5.2 kg/cm ²)
Volume	1.8 pts. in 30 sec.

EXHAUST EMISSION SYSTEMS

See appropriate articles in EXHAUST EMISSION SYSTEMS section.

IGNITION SYSTEM

DISTRIBUTOR

Models are equipped with Bosch single-point distributors or Bosch electronic ignition system.

Other Data & Specifications - See appropriate Bosch ignition system article in DISTRIBUTORS & IGNITION SYSTEMS section.

1974-79 TUNE-UP PROCEDURES

Volvo 4-Cylinder (Cont.)

IGNITION COIL

IGNITION COIL SPECIFICATIONS

Application	Specification
Starting Voltage	20,000 Volts
Maximum Voltage	25,000 Volts

FUEL SYSTEM

FUEL INJECTION

Models are equipped with Bosch CIS fuel injection system or Bosch Lambda/CIS fuel injection system.

Other Data & Specifications - See Bosch CIS or Lambda/CIS Fuel Injection system in FUEL SYSTEMS section.