

1974-79 TUNE-UP PROCEDURES Renault 4-Cylinder

Le Car, R-5, R-12, R-15 & R-17 Series

ENGINE IDENTIFICATION

Vehicle and engine number is marked on a number plate riveted to the left rear side of engine block. Plate is located just below cylinder head mating surface. First 5 digits identify engine.

1974 ENGINE CODES

Application	Code
R-12	
Man. Trans.	841-10
Auto. Trans.	841-11
R-15	
Man. Trans.	841-15
Auto. Trans.	841-16
R-17 G	807-13
R-17 TL	841-15

1975-79 ENGINE CODES

Application	Code
Le Car	810-28
R-5	810-28
R-12	
Man. Trans.	843-10
Auto. Trans.	843-11
R-15 TL & R-17 TL	
Man. Trans.	843-15
Auto. Trans.	843-16
R-17 GTL	843-16
R-17 Gordini	843-13

MODEL IDENTIFICATION

VEHICLE IDENTIFICATION NUMBER

Vehicle Identification Number (VIN) is located on a diamond shaped plate in engine compartment. An oval plate is also used to indicate different models and options. The VIN number is composed of sections "A" and "B" on the diamond plate.

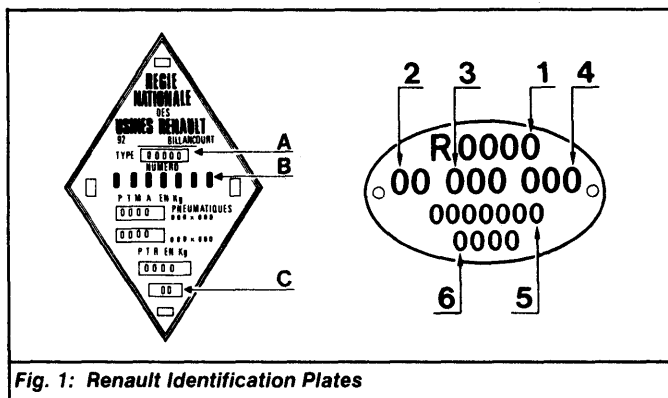

Fig. 1: Renault Identification Plates

1975-79 VIN CODES

Application	Code
Le Car	R-1228
R-5	R-1228
R-12	
Sedan	R-1174
Station Wagon	R-1334
R-15 TL	R-1308
R-17 GTL	R-1328
R-17 Gordini	
Coupe	R-1316
Convertible	R-1326
R-17 TL	
Coupe	R-1328
Convertible	R-1328

VALVE CLEARANCE

Adjust valve clearance to specifications with engine cold.

VALVE CLEARANCE SPECIFICATIONS

Application	Intake	Exhaust
Le Car & R-5	.006" (.15 mm)	.008" (.20 mm)
R-12, R-15, R-15 TL & R-17 GTL & TL	.008" (.20 mm)	.010" (.25 mm)
R-17 G & R-17 Gordini	.010" (.25 mm)	.012" (.30 mm)

VALVE ARRANGEMENT

Le Car, R-5, R-12, R-15 & R-17
E-I-I-E-E-I-I-E - Front-to-rear.

R-17 G & R-17 Gordini

Right Side - All Exhaust.

Left Side - All Intake.

SPARK PLUGS

SPARK PLUG SPECIFICATIONS

Application	Specification
Gap	.024-.026" (.60-.66 mm)
Torque	20 ft. lbs. (27 N.m)

SPARK PLUG TYPE

Application	Champion No.
Le Car	
With Catalytic Converter	L92Y
W/O Catalytic Converter	L87Y
R-5, R-12, R-15, R-15 TL, R-17 GTL & TL	N7Y
R-17 G & R-17 Gordini	N3

HIGH TENSION WIRE RESISTANCE

Carefully remove high tension wires from spark plugs and distributor cap. Using an ohmmeter, check resistance of high tension wires while gently twisting wires. If resistance is not to specification, or fluctuates from infinity to any value, replace high tension wire(s).

HIGH TENSION WIRE RESISTANCE

Application	Resistance (Ohms)
All Models	25,000-30,000

DISTRIBUTOR

DISTRIBUTOR SPECIFICATIONS

Application	Specification
Point Gap	.016-.020" (.4-.5 mm)
Dwell Angle	55-59°
Breaker Arm Spring Tension	16 ozs. (454 g)

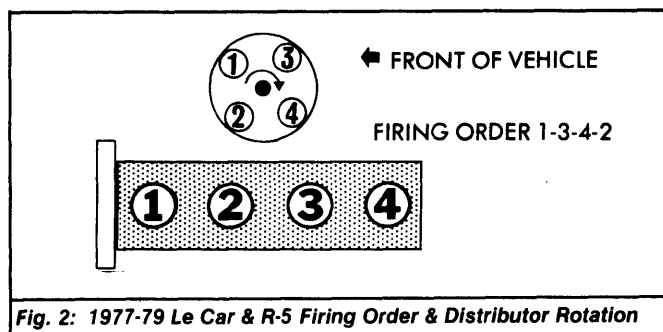

Fig. 2: 1977-79 Le Car & R-5 Firing Order & Distributor Rotation

1974-79 TUNE-UP PROCEDURES

Renault 4-Cylinder (Cont.)

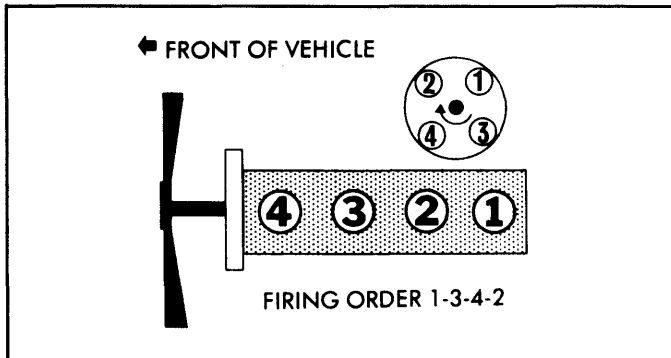

Fig. 3: 1974-76 R-5 Firing Order & Distributor Rotation

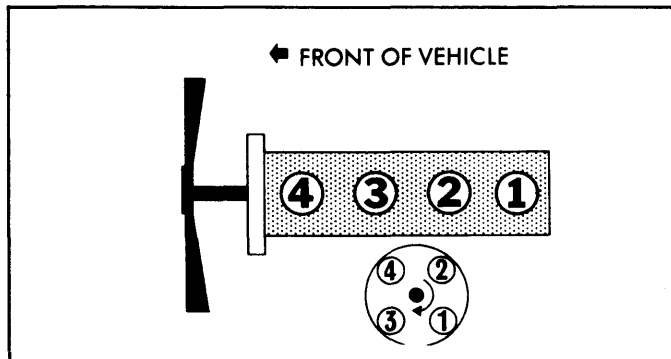

Fig. 4: 1974-76 R-12, R-15 & R-17 Series Firing Order & Distributor Rotation

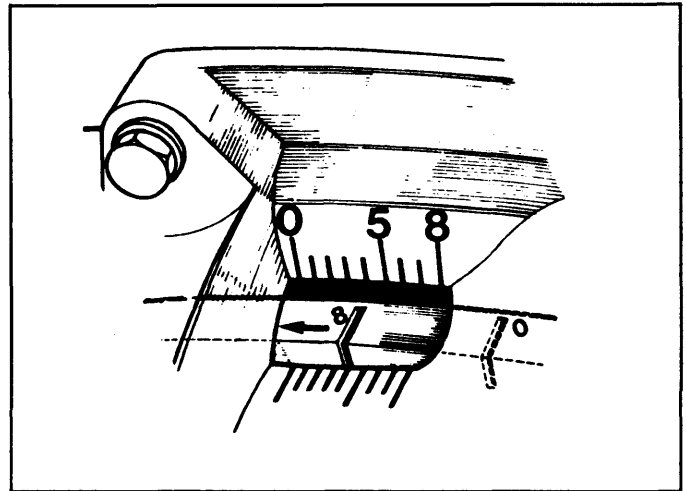

Fig. 5: Renault Ignition Timing Marks (Typical)

1977-79 IGNITION TIMING SPECIFICATIONS

Application	RPM	Timing
Le Car & R-5	800	TDC
R-12		
Man. Trans.	850	7°BTDC
Auto. Trans.	650	7°BTDC
R-17 GTL		7°BTDC
R-17 Gordini	850	1°TDC

1 - Timing should be 12°BTDC with both retard and advance vacuum hoses disconnected.

IGNITION TIMING

- 1) On 1975-79 models, check or adjust ignition timing with vacuum line disconnected and plugged and engine running at idle speed. Leave vacuum hoses connected on 1974 models.
- 2) To adjust timing, turn distributor until specified mark on flywheel is aligned with specified mark on clutch housing. See Fig. 5. Reconnect distributor vacuum hose.

1974 IGNITION TIMING SPECIFICATIONS

Application	Timing @ RPM
R-12, R-15 & R-17 TL	
Man. Trans.	10°BTDC@850
Auto. Trans.	10°BTDC@650
R-17 G	TDC@1000

1975 IGNITION TIMING SPECIFICATIONS

Application	Flywheel Mark	Timing
R-12		
Man. Trans.	1	7°BTDC
Auto. Trans.	1	10°BTDC
R-15 TL & R-17 TL	1	10°BTDC
R-17 Gordini	8	4°BTDC

1976 IGNITION TIMING SPECIFICATIONS

Application	Flywheel Mark	Timing
R-5	1	TDC
R-12, R-15 TL & R-17 TL		
Man. Trans.	1	8°BTDC
Auto. Trans.	1	10°BTDC
R-17 Gordini	1	12°BTDC

IDLE SPEED & MIXTURE

- 1) On R-17 G, turn idle mixture (by-pass) screw to obtain specified idle speed. See Fig. 7. Turn control knob on fuel injection control unit to obtain specified CO% level.
- 2) On all other models, ensure warm air intake system control lever is set to summer position and that choke control knob is pushed all the way in. Apply parking brake and place transmission in Neutral (automatic transmission in Drive).
- 3) Disconnect air pump and adjust mixture screw and throttle screw to obtain specified idle RPM and CO% level. See Fig. 6. Reconnect air pump and check that idle speed is still within specifications.

1974 IDLE SPEED & CO% LEVEL SPECIFICATIONS

Application	Idle RPM	CO%
R-12, R-15 & R-17 TL		
Man. Trans.	850	4.0
Auto. Trans.	650	4.0
R-17 G	1000	2.5-3.0

- 1) Cut off air injection system by clamping hose from diverter valve. Warm engine to operating temperature. Connect tachometer and exhaust gas analyzer to vehicle.
- 2) Place manual transmission in Neutral (automatic transmission in Drive). Turn fuel mixture screw to obtain maximum rich mixture at 800 RPM (650 with automatic transmission).
- 3) Turn throttle plate screw to obtain specified CO% level. Remove clamp on air injection hose and recheck idle speed. If incorrect, repeat adjustments until idle speed and mixture are correct.

- 1) Clamp air injection hose below relief valve to deactivate air injection system. Warm engine to normal operating temperature. Turn throttle plate screw to obtain 850 RPM.
- 2) Turn idle mixture (by-pass) screw to obtain specified CO% level. Turn throttle plate screw, if necessary, to correct idle RPM. Remove air injection hose clamp and recheck idle speed. Idle speed should be 850-950 RPM. Repeat adjustments until idle speed and mixture are correct.

1974-79 TUNE-UP PROCEDURES

Renault 4-Cylinder (Cont.)

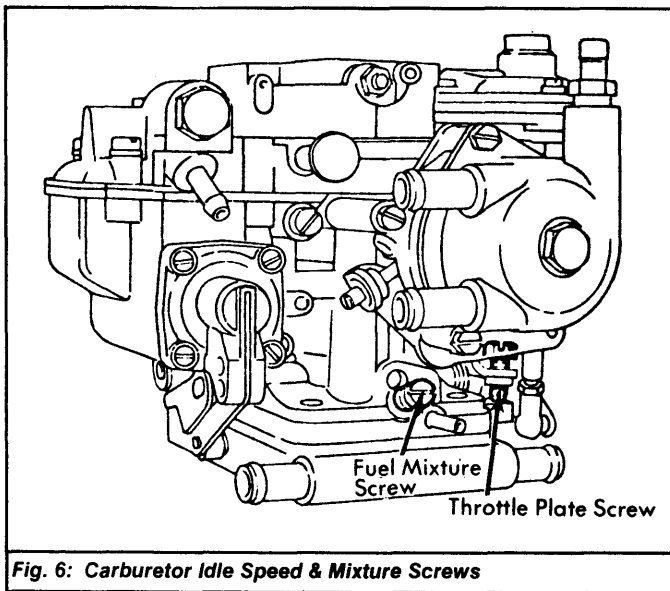

Fig. 6: Carburetor Idle Speed & Mixture Screws

1975-76 IDLE SPEED & CO% LEVEL SPECIFICATIONS

Application	Idle RPM	CO%
R-5	750-850	0.5-3.0
R-12		
Man. Trans.	800-900	¹ 0.5-3.0
Auto. Trans.	625-675	¹ 0.5-3.0
R-15 TL & R-17 TL		
Man. Trans.	800-900	¹ 0.5-3.0
Auto. Trans.	600-700	¹ 0.5-3.0
R-17 Gordini	800-900	1.0-3.0

¹ - Adjust California models to 1.0-4.0 percent CO% level.

1978-79 Models - 1) Cut off air injection system by clamping hose from diverter valve. Warm engine to normal operating temperature. Connect tachometer and exhaust gas analyzer to vehicle.

2) Turn throttle plate screw until engine speed is 700 RPM on models with catalytic converter, 775 RPM on all other models. Turn mixture screw to obtain specified CO% level. Repeat adjustments until idle speed and mixture are correct.

3) Remove clamp from air injection hose and check idle speed. If necessary, adjust idle speed by turning throttle plate screw, then recheck CO% level (with air injection hose clamped).

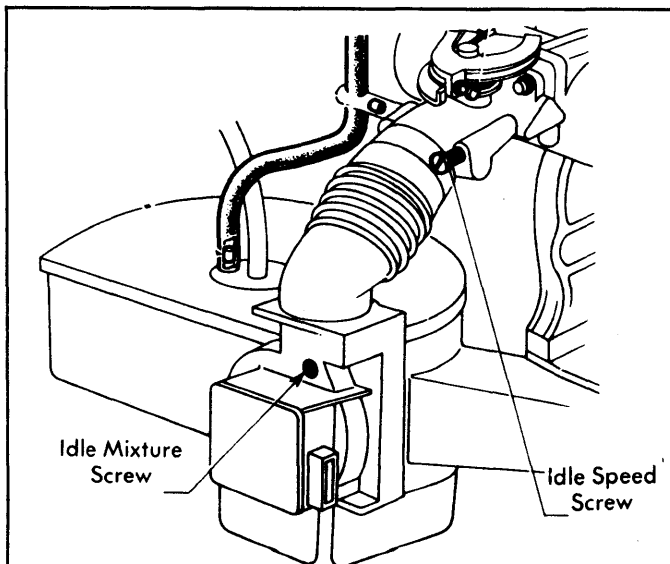

Fig. 7: Fuel Injection Idle Speed & Mixture Screws

1977 IDLE SPEED & CO% LEVEL SPECIFICATIONS

Application	Idle RPM	CO%
R-5	800-900	0.5-3.0
R-12		
Man. Trans.	800-900	¹ 0.5-3.0
Auto. Trans.	600-700	¹ 0.5-3.0
R-17 GTL	600-700	¹ 0.5-3.0
R-17 Gordini	750-850	1.0-3.0

¹ - Adjust California models to 1.0-4.0 percent CO% level.

1978-79 IDLE SPEED & CO% LEVEL SPECIFICATIONS

Application	Idle RPM	CO%
Federal		
With Catalytic Conv.	700-800	0.5-2.5
W/O Catalytic Conv.	800-900	0.5-3.0
Calif.	800-900	0.5-3.0

¹ - Set all 1978 models to 750-850 RPM and 0.5-3.0 percent CO% level.

COLD (FAST) IDLE SPEED

NOTE: Adjustment procedure for 1975 models not available from manufacturer.

1974 Models, Except R-17 G - 1) On manual transmission equipped models, actuate fast idle by connecting a jumper wire between battery positive terminal and accelerator idle solenoid positive terminal.

2) On models with automatic transmission, connect jumper wire between battery ground terminal and accelerator idle solenoid ground terminal. On all models, turn idle air screw on decelerator to obtain fast idle speed.

1976 R-12 Models - 1) Remove choke cover from choke housing. Remove cap from choke vacuum diaphragm. Push throttle plate actuating lever to close choke plates.

2) Push choke rod (inside choke housing) down as far as it will go. Push choke actuating lever against rod and hold it in this position. Measure choke plate opening. If choke plate opening is not 13/64-9/32" (5-7 mm), turn screw in end of choke vacuum diaphragm until correct opening is obtained.

1976-77 R-5, R-15 TL & R-17 TL Models - 1) Ensure idle speed is set to specifications. With ignition off, disconnect negative lead on solenoid flap valve. Activate solenoid flap valve by connecting a jumper wire from battery negative terminal to solenoid negative terminal.

2) Turn screw in end of throttle plate valve to obtain a fast idle speed of 1400-1600 RPM. Remove jumper wire and reconnect negative lead on solenoid flap valve.

FAST IDLE SPECIFICATIONS

Application	RPM
1974 Models	1400-1500
1976 Models	
R-5, R-15 TL & R-17 TL	1450-1550
R-12	¹ 1500
1977 Models	
R-5	
Federal	1800-2000
Calif. & High Altitude	1400-1600
R-12 & R-17 GTL	1400-1600

¹ - With choke plate opening set to 13/64-9/32" (5-7 mm).

1977 R-12 & R-17 GTL Models - 1) Ensure idle speed is set to specifications. Disconnect throttle plate opener capsule from solenoid valve. Connect a vacuum hose between plate opener capsule and intake manifold White vacuum pipe.

2) Increase engine speed to 2500 RPM and let it decrease gradually. Check fast idle imposed by throttle plate opener. Adjust idle speed to specifications by turning screw in end of throttle plate opener capsule.

1974-79 TUNE-UP PROCEDURES

Renault 4-Cylinder (Cont.)

1-103

3) If fast idle is still incorrect, loosen lock nut below throttle plate opener capsule and adjust length of linkage. Tighten lock nut and recheck fast idle setting.

FUEL PUMP

FUEL PUMP SPECIFICATIONS

Application	Specification
Pressure	
Le Car, R-5, R-12, R-15	
R-15 TL, R-17 GTL & TL	2.5-4.0 psi (.18-.28 kg/cm ²)
R-17 G & R-17 Gordini	28-35 psi (2.0-2.5 kg/cm ²)

EXHAUST EMISSION SYSTEMS

See appropriate articles in EXHAUST EMISSION SYSTEMS section.

IGNITION SYSTEM

DISTRIBUTOR

All models are equipped with Ducellier single-point distributors.

Other Data & Specifications - See Ducellier distributors in DISTRIBUTORS & IGNITION SYSTEMS section.

IGNITION COIL

Information not available from manufacturer.

FUEL SYSTEMS

FUEL INJECTION

The R-17 G and R-17 Gordini use a Bosch fuel injection system.

Other Data & Specifications - See appropriate Bosch fuel injection article in FUEL SYSTEMS section.

CARBURETORS

CARBURETORS

Application	Model
Le Car, R-5, R-15,	
R-15 TL, R-17 GTL & TL	Weber 2-Bbl.

Other Data & Specifications - See appropriate Weber Carburetor article in FUEL SYSTEMS section.