

1974-79 TUNE-UP PROCEDURES

Porsche V8

1978-79 928

ENGINE IDENTIFICATION

The engine identification number is stamped on front reinforcing rib on top half of crankcase, directly behind fan. The first 3 digits in engine number identify type and model year.

ENGINE CODES

Application	Code
1978 Models	828
1979 Models	829

MODEL IDENTIFICATION

VEHICLE IDENTIFICATION NUMBER

Vehicle Identification Number is located on left front windshield pillar and is visible from the outside. It is also found on driver's side doorsill.

ENGINE COMPRESSION

With engine at normal operating temperature, remove all plugs. Crank engine through at least 12 compression strokes per cylinder. Pressure should not vary more than 22 psi (1.5 kg/cm²) between cylinders.

VALVE CLEARANCE

Engines are equipped with hydraulic valve lifters, no adjustments are necessary.

VALVE ARRANGEMENT

I-E-I-E-I-E-I-E - Front-to-rear, both banks.

SPARK PLUGS

SPARK PLUG SPECIFICATIONS

Application	Specification
Gap028-.032" (.60-.80 mm)
Torque	18 ft. lbs. (24 N.m)

SPARK PLUG TYPE

Application	Champion No.
All Models	N8Y

HIGH TENSION WIRE RESISTANCE

Carefully remove high tension wires from spark plugs and distributor cap. Using an ohmmeter, check resistance of high tension wires while gently twisting wires. If resistance is not to specification, or fluctuates from infinity to any value, replace wires.

HIGH TENSION WIRE RESISTANCE

Application	Resistance (Ohms)
All Models	25,000-30,000

DISTRIBUTOR

Models are equipped with Bosch electronic ignition system.

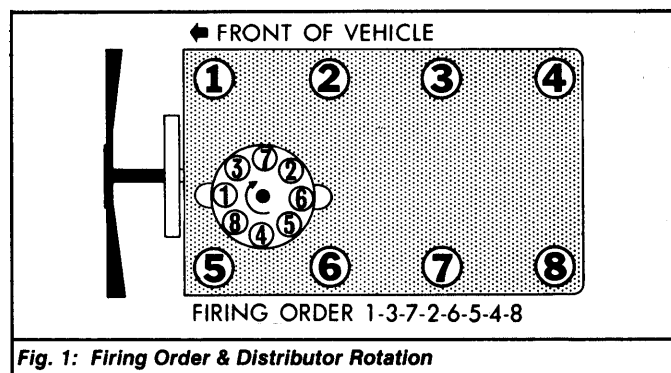

Fig. 1: Firing Order & Distributor Rotation

IGNITION TIMING

- 1) With engine at normal operating temperature, disconnect hose to distributor. Stop engine and connect timing light to No. 1 cylinder wire and tachometer to ignition coil.
- 2) Start engine and increase speed to 3000 RPM. Timing should be 31° BTDC. Adjust timing as necessary by turning distributor. Increase engine speed to 5500 RPM and check that timing is now 33-37° BTDC.
- 3) Return engine to idle and reconnect vacuum hose to distributor. Timing should now read TDC. If not, distributor should be removed and bench tested.

IGNITION TIMING SPECIFICATIONS

Application	RPM	Timing ¹
All Models	3000	31° BTDC

¹ - With distributor vacuum hose disconnected and plugged.

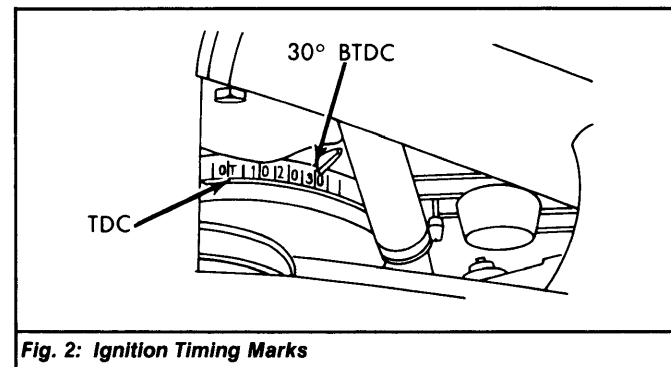

Fig. 2: Ignition Timing Marks

IDLE SPEED & MIXTURE

- 1) Warm engine to normal operating temperature. With ignition timing set to specifications, disconnect right air intake hose and remove upper section of air cleaner. Disconnect and plug air hose at diverter valve, then reinstall air cleaner.
- 2) Connect a tachometer and exhaust gas analyzer to vehicle. Restart engine. Adjust control screw on throttle housing to set RPM to specification. Screw is located behind oil filler container.
- 3) Adjust mixture by inserting Wrench (P 9134) into funnel opening in air cleaner. Press down to engage mixture screw and adjust mixture. Always adjust CO% level from lean to rich.
- 4) Remove wrench and accelerate engine. Check CO% and repeat mixture adjustment if necessary. Recheck idle speed and adjust if necessary. Unplug air hose and reconnect to diverter valve.

IDLE SPEED & CO% LEVEL SPECIFICATIONS

Application	Idle RPM	CO%
All Models	750-850	¹ 2.0-4.0

¹ - Measured at tailpipe and with air pump hose disconnected.

1974-79 TUNE-UP PROCEDURES

Porsche V8 (Cont.)

1-99

FUEL PUMP

FUEL PUMP SPECIFICATIONS

Application	Specification
Pressure	75-84 psi (5.3-5.9 kg/cm ²)
Volume	1.4 qts. in 30 sec.

EXHAUST EMISSION SYSTEMS

See appropriate articles in EXHAUST EMISSION SYSTEMS section.

IGNITION SYSTEM

DISTRIBUTOR

Models are equipped with Bosch electronic ignition system.

Other Data & Specifications - See Bosch Electronic Ignition System article in DISTRIBUTORS & IGNITION SYSTEMS section.

IGNITION COIL

IGNITION COIL SPECIFICATIONS

Application	Resistance (Ohms)
Primary33-.46
Secondary	7000-12,000

FUEL SYSTEM

FUEL INJECTION

All models are equipped with Bosch CIS fuel injection system.

Other Data & Specifications - See Bosch CIS Fuel Injection article in FUEL SYSTEMS section.