

1974-79 TUNE-UP PROCEDURES

Porsche 4-Cylinder

912E, 914, 924

ENGINE IDENTIFICATION

On 914 1.8L engine, engine identification number is located on right side of crankcase, behind air cleaner. On 914 2.0L engine, engine identification number is located on rear upper part of crankcase, between oil filler neck and blower housing.

On 912E, engine identification number is located on side of crankcase, next to oil temperature sensor. On 924, engine identification number is located on left side of crankcase, next to clutch housing.

1974-76 ENGINE CODES

Application	Code
1974 Models	
1.8L	EC
2.0L	GA
1975-76 Models	
912E	O
914	
1.8L	
Federal	EC-A
Calif.	EC-B
2.0L	
Federal	GC-A
Calif.	GC-B

1977-79 ENGINE CODES

Application	Code
1977 Models	
Federal	XH
California	XF
1978-79 Models	
Federal	XG
California	XE

MODEL IDENTIFICATION

VEHICLE IDENTIFICATION NUMBER

On 912E and 924 models, Vehicle Identification Number is visible through windshield and is stamped on a plate attached to left windshield pillar. On 914 models, Vehicle Identification Number is attached to rear panel in luggage compartment.

ENGINE COMPRESSION

Test compression pressure with fully open throttle, oil temperature above 140°F (60°C), all spark plugs removed, and engine at cranking speed. Each cylinder should be allowed about 12 compression strokes. Differences between cylinders should not exceed 22 psi (1.5 kg/cm²).

COMPRESSION PRESSURE SPECIFICATIONS

Application	Stand. Pressure psi (kg/cm ²)	Min. Pressure psi (kg/cm ²)
1974-76 Models	128-156 (9.0-11.0)	100 (7.0)
1977-78 Models	114-156 (8.0-11.0)	85 (6.0)
1979 Models	142-184 (9.9-12.9)	107 (7.5)

VALVE CLEARANCE

1974-76 Models - Check or adjust valve clearance with engine cold. See VALVE CLEARANCE SPECIFICATIONS table.

1977-79 Models - 1) Check or adjust valve clearance with engine oil temperature at 176°F (80°C). To adjust, remove cylinder head cover and turn crankshaft until cam lobes of cylinder to be adjusted point upward.

2) Correct valve clearance by making complete turns of adjusting screw, using Adjuster (US 8005). See Fig. 1. One turn changes clearances by .002" (.05 mm). Various adjusting screws are also available. Camshaft must be removed to replace screws.

VALVE CLEARANCE SPECIFICATIONS

Application	Clearance In. (mm)
1974-76 Models	
Intake006 (.15)
Exhaust008 (.20)
1977-79 Models	
Intake008 (.20)
Exhaust018 (.45)

¹ - Set clearance to .006 (.15) on 1.8L engine.

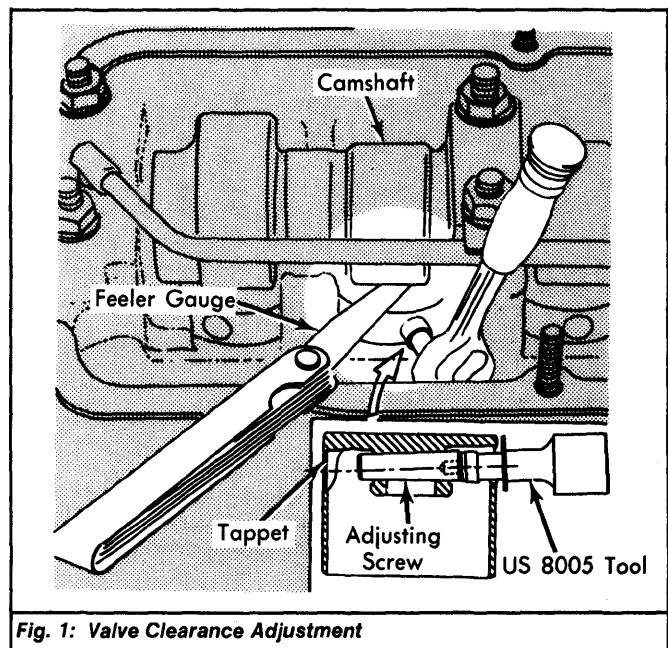

Fig. 1: Valve Clearance Adjustment

VALVE ARRANGEMENT

912E & 914

E-I-I-E - Front-to-rear, both banks.

924

I-E-I-E-I-E-I-E - Front-to-rear.

SPARK PLUGS

SPARK PLUG SPECIFICATIONS

Application	Specification
Gap028" (.7 mm)
Torque	22 ft. lbs. (30 N.m)

SPARK PLUG TYPE

Application	Champion No.
All Models	N8Y

HIGH TENSION WIRE RESISTANCE

Carefully remove high tension wires from spark plugs and distributor cap. Using an ohmmeter, check resistance of high tension wires while gently twisting wire. If resistance is not to specification, or fluctuates from infinity to any value, replace high tension wire(s).

HIGH TENSION WIRE RESISTANCE

Application	Resistance (Ohms)
All Models	25,000-30,000

DISTRIBUTOR

Models are equipped with Bosch single-point distributors or Bosch electronic ignition systems.

1974-79 TUNE-UP PROCEDURES Porsche 4-Cylinder (Cont.)

DISTRIBUTOR SPECIFICATIONS

Application	Specification
Air Gap ¹010" (.25 mm)
Point Gap016" (.40 mm)
Dwell Angle	44-50°
Breaker Arm Spring Tension	14-21 ozs. (400-600 g)

¹ - Electronic ignition system only.

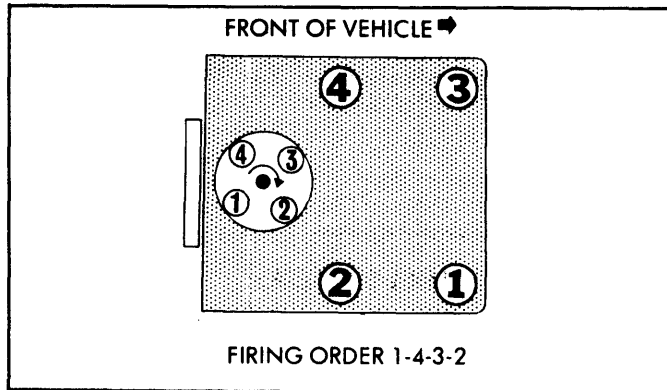

Fig. 2: 912E & 914 Firing Order & Distributor Rotation

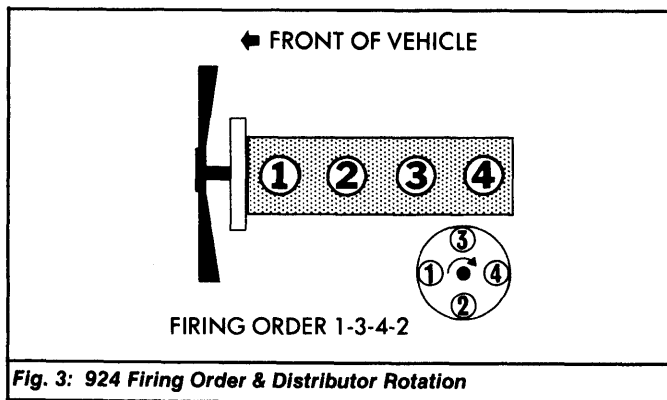

Fig. 3: 924 Firing Order & Distributor Rotation

IGNITION TIMING

1974-76 Models - Check or adjust ignition timing with engine at specified RPM. Disconnect and plug both distributor vacuum advance hoses. Adjust timing by turning distributor until mark aligns with timing pointer.

1977-79 Models - Check or adjust ignition timing with engine at specified RPM and both distributor vacuum advance hoses connected. Adjust timing by turning distributor until mark on flywheel aligns with reference edge on clutch housing. See Fig. 4.

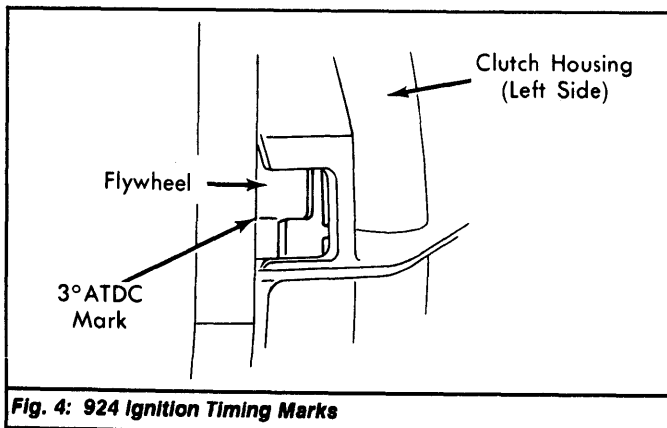

Fig. 4: 924 Ignition Timing Marks

IGNITION TIMING SPECIFICATIONS

Application	RPM	Timing
1974-76 Models		
1.8L	800-900	7.5° BTDC
2.0L	3500	27° BTDC
1977 Models	850-1000	10° ATDC
1978-79 Models	900-1000	3° ATDC

IDLE SPEED & MIXTURE

1974 Models - 1) With engine at normal operating temperature, connect tachometer and exhaust gas analyzer to vehicle. Disconnect hose from charcoal canister at air cleaner.

2) Adjust idle speed to specifications by turning idle air by-pass screw on throttle housing. Check CO% level. On 2.0L engine, adjust CO% level by turning adjustment knob on potentiometer. On 1.8L engine, adjust CO% level by turning air by-pass screw on intake air sensor (mounted on upper air cleaner assembly).

1975-76 Models - 1) Ensure ignition timing and valve clearances are set to specifications. With engine at normal operating temperature, connect tachometer and exhaust gas analyzer to vehicle. Exhaust gas analyzer probe must be inserted into test connection in front of catalytic converter.

2) On California 2.0L engine, disconnect and plug air injection hose at air pump. On all models, disconnect hose from charcoal canister at air cleaner. Adjust idle speed to specifications by turning idle air by-pass screw on throttle housing.

3) Check CO% level. On 2.0L engine, adjust CO% level by turning adjustment knob on potentiometer. The 1.8L engine CO% level adjustment screw is factory sealed.

1974-76 IDLE SPEED & CO% LEVEL SPECIFICATIONS

Application	Idle RPM	CO%
912E	875-975	0.5-1.2
914		
1.8L	800-900	0.2-0.8
1.9L	850-950	1.0-3.0

1977-79 Models - 1) With engine at normal operating temperature, connect tachometer and exhaust gas analyzer to vehicle. Exhaust gas analyzer probe must be inserted into test connection in front of catalytic converter.

2) Disconnect and plug air injection air pump hose at diverter valve. Disconnect and plug charcoal canister-to-air cleaner hose. On California models, detach and plug air diverter valve hose.

3) Adjust idle speed to specifications by turning idle air by-pass screw on throttle valve housing. Remove plug in mixture control unit between fuel distributor and venturi or puncture plastic cap with small screwdriver.

4) Insert Wrench (P377) and adjust CO% level. Always adjust CO% level from lean to rich. Never apply pressure to wrench during adjustment. Remove wrench and accelerate engine.

5) Check CO% level and repeat procedure, if necessary. Recheck idle speed, adjusting as necessary. With adjustments completed, reinstall mixture control plug and restore all components to original positions.

1977-79 IDLE SPEED & CO% LEVEL SPECIFICATIONS

Application	Idle RPM	¹ CO%
1977 Models		
Federal	850-1000	1.0-2.0
Calif.	850-1000	0.7-1.3
High Alt.	850-1000	0.7
1978-79 Models		
Federal	900-1000	0.7-1.1
Calif.	900-1000	0.8-1.2

¹ - With air injection and charcoal canister hoses disconnected and plugged.

1974-79 TUNE-UP PROCEDURES

Porsche 4-Cylinder (Cont.)

FUEL PUMP

FUEL PUMP SPECIFICATIONS

Application	Specification
Pressure	
1974-78 Models	36 psi (2.5 kg/cm ²)
1979 Models	65-75 psi (4.6-5.3 kg/cm ²)
Volume	1 qt. in 40 sec.

EXHAUST EMISSION SYSTEMS

See appropriate articles in EXHAUST EMISSION SYSTEMS section.

IGNITION SYSTEM

DISTRIBUTOR

Models are equipped with Bosch single-point distributors or Bosch electronic ignition systems.

Other Data & Specifications - See appropriate Bosch ignition system article in DISTRIBUTORS & IGNITION SYSTEMS section.

IGNITION COIL

IGNITION COIL SPECIFICATIONS

Application	Resistance (Ohms)
Primary	1.0-1.35
Secondary	5500-8000

FUEL SYSTEMS

FUEL INJECTION

Models are equipped with Bosch AFC, CIS, or MPC fuel injection.
Other Data & Specifications - See appropriate Bosch fuel injection article in FUEL SYSTEMS section.