

1974-79 TUNE-UP PROCEDURES

Opel 4-Cylinder

Manta, 1.8 (1800), 1900

ENGINE IDENTIFICATION

Engine serial number is stamped on a machined pad at the top right front corner of engine block. On 1974-75 models, number starts with 19E US, denoting displacement in Liters and also that engine is equipped with emission control systems.

MODEL IDENTIFICATION

VEHICLE IDENTIFICATION NUMBER

Vehicle Identification Number is stamped on a plate which is attached driver's side of dash and visible through windshield.

ENGINE COMPRESSION

Check compression pressure with engine at normal operating temperature. Remove all spark plugs and air cleaner element. Hold throttle valve wide open and crank engine at 300 RPM (minimum). Maximum variation between cylinders should be 9 psi (.63 kg/cm²).

COMPRESSION PRESSURE SPECIFICATIONS

Application	Min. Pressure psi (kg/cm ²)	Std. Pressure psi (kg/cm ²)
All Models	120 (8.4)	170 (12)

VALVE CLEARANCE

1976-79 Models - Check valve clearance with engine cold. Make sure rocker arm shaft nuts are torqued to 16 ft. lbs. (22 N.m). Bring piston No. 1 to Top Dead Center (TDC) of compression stroke. Adjust valves as listed in VALVE CLEARANCE ADJUSTMENT SEQUENCE table. Rotate crankshaft 360 degrees until No. 4 cylinder is at TDC and adjust remaining valves.

VALVE CLEARANCE ADJUSTMENT SEQUENCE

Application	Adjust Valve No.
Piston No. 1 at TDC	
Intake	1, 2
Exhaust	1, 3
Piston No. 4 at TDC	
Intake	3, 4
Exhaust	2, 4

VALVE CLEARANCE SPECIFICATIONS

Application	Clearance In. (mm)
Intake	.006 (.15)
Exhaust	.010 (.25)

VALVE ARRANGEMENT

1974-75 Models

E-I-I-E-E-I-I-E - Front-to rear.

1976-79 Models

Right Side - All Intake.

Left Side - All Exhaust.

SPARK PLUGS

SPARK PLUG SPECIFICATIONS

Application	Specification
Gap	.030" (.8 mm)
Torque	
1974-75 Models	29 ft. lbs. (39 N.m)
1976-79 Models	15-22 ft. lbs. (20-30 N.m)

SPARK PLUG TYPE

Application	NGK
1974-75 Models	1 AC42FS
1976-79 Models	BPR6ES

¹ - AC spark plug number. Use spark plug No. AC43FS if spark plug fouling occurs.

HIGH TENSION WIRE RESISTANCE

Carefully remove high tension wires from spark plugs and distributor cap. Using an ohmmeter, check resistance of wires while gently twisting wires. If resistance is not to specifications or fluctuates from infinity to any value, replace wire(s).

HIGH TENSION WIRE RESISTANCE

Application	Resistance (Ohms)
All Models	25,000-30,000

DISTRIBUTOR

Models are equipped with Bosch or Nippondenso single-point distributors.

DISTRIBUTOR SPECIFICATIONS

Application	Specification
Point Gap	.016-.020" (.4-.5 mm)
Dwell Angle	47-52°
Breaker Arm Spring Tension	14-19 ozs. (400-540 g)
Condenser Capacity	.25 mfd.

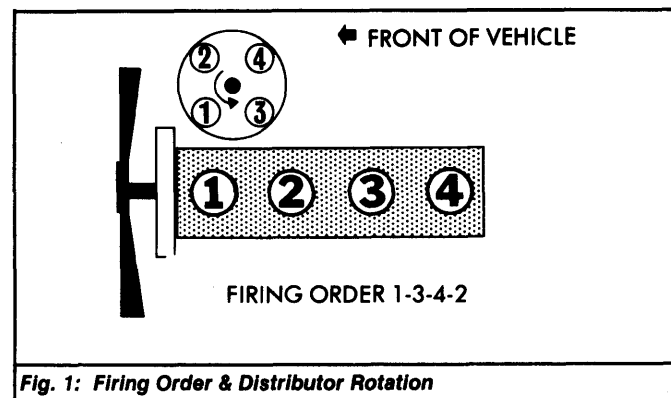

Fig. 1: Firing Order & Distributor Rotation

IGNITION TIMING

1974-75 Models - Check or adjust ignition timing with engine at normal operating temperature. Disconnect and plug vacuum advance/retard hoses. Timing is set correctly when timing mark (steel ball) on crankshaft pulley (flywheel) is aligned with timing pointer. See Fig. 2. To adjust, loosen distributor hold-down bolt and rotate distributor.

1976-79 Models - 1) Make sure distributor point gap is set correctly and engine is idling smoothly and at correct RPM. Start and run until engine is at normal operating temperature. Stop engine. Connect tachometer and timing light to No. 1 cylinder.

2) Adjust timing by rotating distributor clockwise or counterclockwise until notch on pulley aligns with 6°BTDC mark on machined pad on front cover ("0" mark is TDC). See Fig. 3.

IGNITION TIMING SPECIFICATIONS

Application	RPM	Timing
1976-79 Models	900	6°BTDC

1974-79 TUNE-UP PROCEDURES

Opel 4-Cylinder (Cont.)

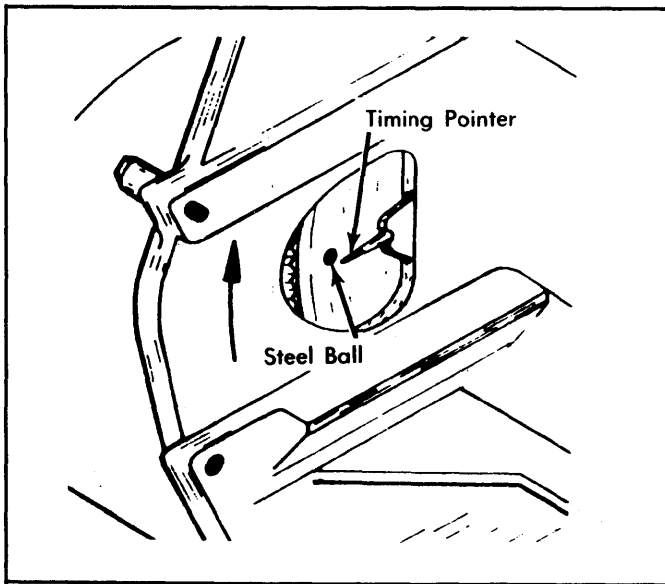

Fig. 2: 1.9L Engine Ignition Timing Marks

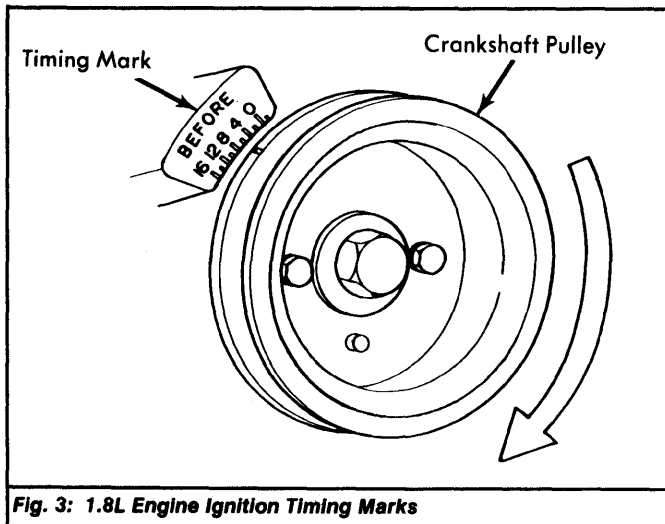

Fig. 3: 1.8L Engine Ignition Timing Marks

IDLE SPEED & MIXTURE

1974 Models - 1) Ensure EGR system is working properly. Make sure spark plug gap and distributor point gap are adjusted properly. Ignition timing and valve clearance should also be properly adjusted. 2) Connect tachometer to engine. With air cleaner installed, warm engine to normal operating temperature. Remove plastic caps from idle mixture screw and air speed screw. Adjust idle mixture screw and air speed screw to obtain specified RPM and CO% level.

1974 IDLE SPEED & CO% LEVEL SPECIFICATIONS

Application	RPM	CO%
Man. Trans.	850-900	1.0-2.0
Auto. Trans.	800-850	1.0-2.0

1975 Models - 1) Warm engine to normal operating temperature. With accelerator linkage correctly adjusted, connect tachometer to engine. Connect Idle Drop Tester (J-25401-1) between airflow meter and wiring harness connector. Clamp off air hose between throttle body and deceleration valve.

2) Start engine. Set tester switch to INCREASED IDLE position. Engine should now idle at increased idle RPM specifications. If not, correct setting by turning idle air adjustment screw on throttle body. 3) Set tester switch to NORMAL IDLE position. Engine should now run at normal idle RPM specifications. If idle RPM is lower than specified,

go to next step. If idle RPM is higher than specified, go to step 5). 4) Check intake manifold for leaks and repair as necessary. If no leaks are found, remove plastic cap from by-pass mixture screw on airflow meter and turn by-pass screw clockwise 1/2 turn at a time until specified RPM is obtained. Repeat step 2) before proceeding to step 6). 5) Remove plastic cap from by-pass mixture screw on airflow meter and turn by-pass screw counterclockwise 1/2 turn at a time until specified RPM is obtained. Repeat step 2) before proceeding to next step. 6) Remove clamp from air hose leading to deceleration valve. If RPM changes from normal idle position, correct RPM by turning idle air adjustment screw at throttle body. Install plastic cap on airflow meter by-pass mixture screw. Disconnect tachometer and tester.

1975-79 IDLE SPEED SPECIFICATIONS

Application	Increased Idle RPM	Normal Idle RPM
1975 Models	1050-1075	900-1000
1976-79 Models		900

1976-79 Models - 1) Make sure spark plug gap, distributor point gap, and accelerator control are adjusted properly. Ignition timing and valve clearance should be properly adjusted. Carburetor float level should be set to specifications.

2) Place transmission in Neutral. Turn air conditioning off (if equipped). Leave air cleaner installed, vacuum lines to distributor and idle compensator disconnected and plugged.

NOTE: Information (RPM and number of turns) enclosed in parentheses applies to California and High Altitude vehicles only.

3) Turn mixture adjusting screw all the way in, then back out 4 1/2 (3) turns. Adjust idle speed screw until 950 (900) RPM is reached. Adjust idle mixture screw for maximum RPM.

4) Readjust idle speed screw for 950 (900) RPM. Turn mixture adjusting screw clockwise (lean) until 900 (850) RPM is reached. Then turn idle mixture screw 1/2 turn counterclockwise (rich). Adjust idle speed screw for a final speed of 900 RPM.

5) On A/C equipped vehicles, turn air conditioning on maximum cold and high blower. Open throttle enough to allow speed up solenoid to reach full travel, then adjust speed up controller adjusting screw for an idle speed of 900 RPM.

COLD (FAST) IDLE RPM

1974 Models - Remove air cleaner cover. Warm engine to normal operating temperature. With lever on highest step of fast idle cam, adjust fast idle speed by turning nuts on throttle connecting linkage. Shortening linkage will decrease idle RPM, lengthening linkage will increase idle RPM.

1976-79 Models - 1) Warm engine to normal operating temperature. Disconnect and plug distributor, EGR, and hot idle compensator vacuum hoses. Remove air cleaner cover.

2) With engine off, open throttle slightly, close choke valve and release throttle. Start engine without moving throttle. Using fast idle speed screw, set fast idle speed to specifications.

COLD (FAST) IDLE SPECIFICATIONS¹

Application	Man. Trans. RPM	Auto. Trans. RPM
1974 Models	3200	3200
1976-77 Models	3200	3000
1978 Models		
Federal	3400	3200
Calif.	3400	3000
1979 Models	2800	3000

¹ - Cold fast idle is not adjustable on 1975 models.

DASHPOT ADJUSTMENT

1977-79 Models - 1) Check that engine speed at which the dashpot shaft contacts throttle lever is within specifications. If not, hold engine speed to specification by using throttle lever.

1974-79 TUNE-UP PROCEDURES

Opel 4-Cylinder (Cont.)

2) Loosen lock nut and turn dashpot until end of shaft contacts throttle lever. Tighten lock nut. Check that idle speed is set to specification and reset if necessary.

DASHPOT ADJUSTMENT SPECIFICATIONS

Application	RPM
1977-78 Models	
Federal	2600-3000
Calif.	2400-2400
1979 Models	2000-2400

FUEL PUMP

FUEL PUMP SPECIFICATIONS

Application	Specification
Pressure	2.4-3.3 psi (.17-.23 kg/cm ²)
Volume85 qt. in 1 min.

IGNITION SYSTEM

DISTRIBUTOR

Models are equipped with Bosch or Nippondenso single-point distributors.

Other Data & Specifications - See appropriate Bosch or Nippondenso distributor articles in DISTRIBUTORS & IGNITION SYSTEMS section.

IGNITION COIL

IGNITION COIL SPECIFICATIONS

Application	Resistance (Ohms)
1976-79 Models	
Primary	1.33-1.47
Secondary	7650-9350

FUEL SYSTEMS

FUEL INJECTION

All 1975 models are equipped with Bosch AFC fuel injection system.
Other Data & Specifications - See Bosch AFC Fuel Injection article in FUEL SYSTEMS section.

CARBURETORS

CARBURETORS

Application	Type
1974 Models	Solex 2-Bbl.
1976-79 Models	Nikki 2-Bbl.

Other Data & Specifications - See appropriate Solex or Nikki Carburetor article in FUEL SYSTEMS section.