

1974-79 TUNE-UP PROCEDURES

Mazda 4-Cylinder

1-57

GLC, Mizer, B1600,
B1800, B2000, 626, 808

ENGINE IDENTIFICATION

Engine serial number and model code are stamped on right front upper wall of cylinder block.

1978-79 ENGINE CODES

Application	Code
GLC	TC
626	MA
B1800	VB
B2000	MA

MODEL IDENTIFICATION

VEHICLE IDENTIFICATION NUMBER

Vehicle Identification Number is stamped on plate riveted to right rear corner of engine compartment. On GLC models, number is also stamped on plate located at left inner corner of windshield and visible through windshield.

ENGINE COMPRESSION

Check compression pressure with engine at normal operating temperature, spark plugs removed, throttle valve wide open and engine at cranking speed (300 RPM). Crank engine until maximum pressure is reached at each cylinder. Compression is normal if lowest cylinder reading is at least 75% of highest reading.

1974-76 COMPRESSION PRESSURE SPECIFICATIONS

Application	Pressure psi (kg/cm ²)
All Models	
Minimum	118 (8.3)
Maximum	164 (11.5)

1977 COMPRESSION PRESSURE SPECIFICATIONS

Application	Pressure psi (kg/cm ²)
808 (1600 cc)	169 (11.8)
All Others	164 (11.5)

1978-79 COMPRESSION PRESSURE SPECIFICATIONS

Application	Pressure psi (kg/cm ²)
GLC	149 (10.5)
626	171 (12.0)
B1800	169 (11.8)
B2000	171 (12.0)

VALVE CLEARANCE

VALVE CLEARANCE SPECIFICATIONS¹

Application	Intake In. (mm)	Exhaust In. (mm)
GLC010 (.25)	.012 (.30)
Mizer010 (.25)	.012 (.30)
626012 (.30)	.012 (.30)
808		
1300 cc010 (.25)	.012 (.30)
1600 cc012 (.30)	.012 (.30)
B1600012 (.30)	.012 (.30)
B1800012 (.30)	.012 (.30)
B2000012 (.30)	.012 (.30)

¹ - Adjust valves with engine hot.

VALVE ARRANGEMENT

Right Side - All Exhaust.
Left Side - All Intake.

SPARK PLUGS

SPARK PLUG SPECIFICATIONS

Application	Specification
Gap	¹ .029-.033" (.75-.85 mm)
Torque	11-15 ft. lbs. (15-20 N.m)

¹ - Set to .51" (1.3 mm) on 1976 Federal 1300 cc engine.

SPARK PLUG TYPE

Application	NGK
1974-78 Models	¹ BP6ES
1979 Models	¹ BP5ES

¹ - Use BPR6ES (BPR5ES) where required for suppression of radio interference.

HIGH TENSION WIRE RESISTANCE

Carefully remove high tension wires from spark plugs and distributor cap. Using an ohmmeter, check resistance of wires while gently twisting wire. If resistance is not to specification, or fluctuates from infinity to any value, replace wire.

HIGH TENSION WIRE RESISTANCE

Application	Resistance (Ohms)/Foot
All Models	4875

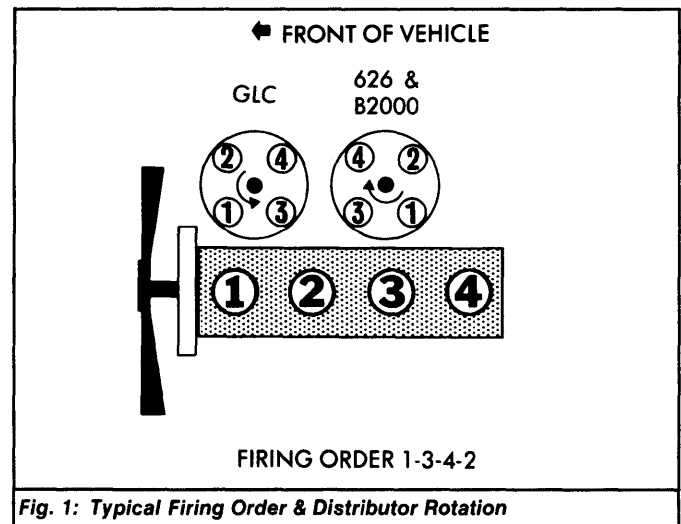

DISTRIBUTOR

Vehicles are equipped with Mitsubishi single-point distributor, Mitsubishi dual-point distributor, or Mitsubishi electronic ignition system.

1974-78 DISTRIBUTOR SPECIFICATIONS

Application	Specifications
Air Gap	¹ .010-.014" (.25-.35 mm)
Point Gap018-.022" (.45-.55 mm)
Dwell Angle	49-55°
Breaker Arm Spring Tension	16-21 ozs. (450-600 g)
Condenser Capacity20-.24 mfd.

¹ - Electronic ignition equipped models only.

1979 DISTRIBUTOR SPECIFICATIONS

Application	Specifications
Air Gap	
GLC010" (.25-.35 mm)
626008" (.20 mm)
B2000008-.024" (.20-.60 mm)

1974-79 TUNE-UP PROCEDURES

Mazda 4-Cylinder (Cont.)

IGNITION TIMING

1974-76 Models - 1) On single-point distributor equipped models, check or adjust ignition timing with engine at normal operating temperature, idle speed set to specifications, and all vacuum and electrical leads connected.

2) On dual-point distributor equipped models, check or adjust ignition timing with engine at normal operating temperature and idle speed set to specifications. Set retard spark with all vacuum and electrical leads connected and advance spark with retard points' primary lead disconnected.

1974-75 IGNITION TIMING SPECIFICATIONS

Application	Timing
Dual-Point Models	
Sedan & Coupe	¹ 5°BTDC
Station Wagon	² 8°BTDC
Single-Point Models	5°BTDC

¹ - Set retard timing to TDC.

² - Set retard timing to 4°BTDC.

1976 IGNITION TIMING SPECIFICATIONS

Application	Timing
808	
1300 cc	
Federal	7°BTDC
Calif.	11°BTDC
1600 cc	
Federal	5°BTDC
Calif.	8°BTDC
B1600	
Federal	5°BTDC
Calif.	8°BTDC

1977 GLC & Mizer Models - 1) With engine at normal operating temperature, set idle speed to specification. Place manual transmission in Neutral (automatic transmission in Drive) and connect timing light to engine.

2) Start engine and rotate distributor until specified mark on crankshaft pulley aligns with indicator pin. After checking and setting base timing on 1977 Mizer, disconnect accelerator switch and check advanced timing.

1977 808 (1600 cc) Models - 1) With engine at normal operating temperature, set idle speed to specification. Place manual transmission in Neutral (automatic transmission in Drive) and connect timing light to engine.

2) On Federal models, unplug connector going to distributor. Attach a jumper wire between advance terminals of connector halves to operate advance timing. Check advance timing.

3) If advance timing is incorrect, loosen and rotate distributor housing until timing is correct. Tighten distributor and recheck timing. On Federal models, remove jumper wire and reconnect connector to distributor.

4) Check retard timing. If retard timing is incorrect, loosen retard breaker plate set screws and adjust position of breaker plate set. DO NOT rotate distributor housing when correcting retard timing.

1977 IGNITION TIMING SPECIFICATIONS

Application	Timing
GLC	
Man. Trans.	1 7°BTDC
Auto. Trans.	11°BTDC
Mizer	
Federal	² 8-13°BTDC
Calif.	11°BTDC
High Alt.	11°BTDC
808 (1600 cc)	
Federal	³ 13°BTDC
Calif.	7-9°BTDC

¹ - Set to 11°BTDC on California models.

² - Retard timing is 6-8°BTDC.

³ - Retard timing is 4-6°BTDC.

1978-79 Models - 1) With engine at normal operating temperature, set idle speed to specification. Place manual transmission in Neutral (automatic transmission in Drive) and connect timing light to engine. Start engine and rotate distributor until specified mark on crankshaft pulley aligns with indicator pin.

2) After checking and setting base timing on 1979 626 and 1978 Federal GLC manual transmission equipped models, disconnect water thermo (accelerator) switch and check advanced timing.

1978 IGNITION TIMING SPECIFICATIONS

Application	Man. Trans.	Auto. Trans.
GLC		
Federal	1 7°BTDC	11°BTDC
Calif.	11°BTDC	11°BTDC
B1800	8°BTDC	

¹ - Advanced timing is 11°BTDC.

1979 IGNITION TIMING SPECIFICATIONS

Application	Man. Trans.	Auto. Trans.
GLC		
Federal	7°BTDC	7°BTDC
Calif.	5°BTDC	5°BTDC
626 ¹	8°BTDC	8°BTDC
B2000	8°BTDC	

¹ - Advanced timing is 16°BTDC.

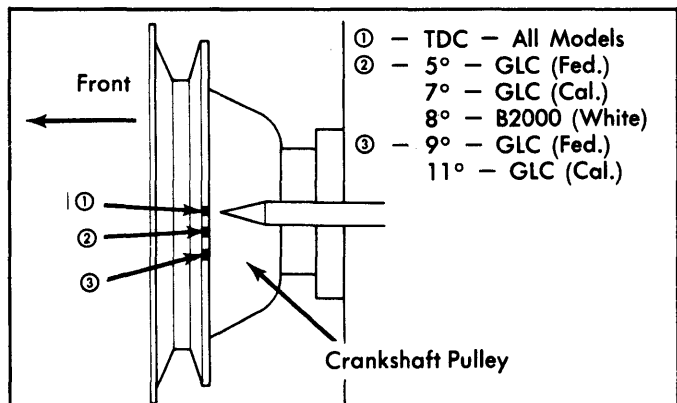

Fig. 2: Typical GLC & B2000 Ignition Timing Marks

IDLE SPEED & MIXTURE

1974-76 Models - 1) Connect tachometer and vacuum gauge to engine. With engine at normal operating temperature and choke valve fully open, check that fuel level is at mark on float bowl sight glass.

2) Set idle speed to specification. Remove limiter caps and adjust mixture screws until highest, steady intake manifold vacuum is obtained with smooth engine operation.

3) Connect exhaust gas analyzer to vehicle. Adjust CO% level to specification and reset idle speed as necessary. Continue adjustments until idle speed and CO% level are within specifications.

1974-75 IDLE SPEED & CO% LEVEL SPECIFICATIONS ¹

Application	Idle RPM	CO%
Federal	800-850	0.7-1.5
Calif.	800-850	1.5-2.5

¹ - Set all 1974 models to 800-850 RPM and CO% level to 1.5-2.5 percent.

1974-79 TUNE-UP PROCEDURES

Mazda 4-Cylinder (Cont.)

1976 IDLE SPEED & CO% LEVEL SPECIFICATIONS

Application	Idle RPM	CO%
808		
1300 cc		
Federal	700-750	0.3-1.0
Calif.	700-750	1.5-2.5
1600 cc	800-850	1.0-2.0
B1600	800-850	1.0-2.0

1977-79 Models - 1) Set parking brake and block wheels. Turn accessories off. Connect tachometer and exhaust gas analyzer to vehicle. Disconnect canister purge hose from air cleaner.

2) With manual transmission in Neutral (automatic transmission in Drive), turn idle speed adjusting screw as necessary to obtain specified idle RPM.

3) On Federal GLC models, disconnect hose between air silencer and reed valve. On California GLC models and B1800/B2000 models, disconnect hose between air pump and check valve. Plug check valve port.

4) Turn mixture adjusting screw as necessary to obtain specified CO% level. Reconnect hose, recheck idle speed, and readjust if necessary. Install mixture screw limiter cap (if removed).

1977-78 IDLE SPEED & CO% LEVEL SPECIFICATIONS

Application	¹ Idle RPM	² CO%
GLC & Mizer		
Man. Trans.	700-750	1.5-2.5
Auto. Trans.	600-650	1.5-2.5
808 (1600 cc)		
Man. Trans.		
Federal	800-850	.3-1.0
Calif.	800-850	1.0-2.0
Auto. Trans.		
Federal	650-700	0.3-1.0
Calif.	650-700	1.0-2.0

¹ - Air injection connected.

² - Air injection disconnected.

1979 IDLE SPEED & CO% LEVEL SPECIFICATIONS

Application	¹ Idle RPM	² CO%
GLC		
Man. Trans.	650-750	1.0-3.0
Auto. Trans.	550-650	1.0-3.0
626	600-700	2.0-4.0
B2000	600-700	2.0-4.0

¹ - Air injection connected.

² - Air injection disconnected.

COLD (FAST) IDLE RPM

1974-76 Models - With choke valve fully closed, measure clearance between primary throttle valve and throttle bore. If clearance is not within specifications, bend choke rod until proper clearance is obtained.

1974-76 FAST IDLE SPECIFICATIONS

Application	Clearance In. (mm)
808	
1300 cc	.05 (1.3)
1600 cc	.07 (1.8)
B1600	.07 (1.8)

1977-79 Models - 1) Connect tachometer to engine. Warm engine to normal operating temperature. Ensure slow idle speed and mixture are correct.

2) Stop engine and remove air cleaner. Restart and run engine at idle. Loosen screw holding outer choke cable to carburetor. Hold choke valve wide open and pull choke cable fully out. Engine speed should be 3000-4000 RPM (2500-3500 RPM on 808 1600 cc engine).

3) If adjustment is needed, remove carburetor from engine and bend choke connecting rod to obtain specified clearance between lower edge of primary throttle valve and wall of bore with choke valve closed.

1977-79 FAST IDLE SPECIFICATIONS

Application	Clearance In. (mm)
GLC	.054 (1.37)
Mizer	.054 (1.37)
626	.039 (1.0)
B1800	.055 (1.4)
B2000	.055 (1.4)
808 (1600 cc)	.068 (1.7)

FUEL PUMP

FUEL PUMP SPECIFICATIONS

Application	Specification
Pressure (At Idle)	2.8-3.6 psi (.20-.25 kg/cm ²)
Volume (At Idle)	.8 qts. in 1 minute

EXHAUST EMISSION SYSTEMS

See appropriate articles in EXHAUST EMISSION SYSTEMS section.

IGNITION SYSTEM

DISTRIBUTOR

Vehicles are equipped with Mitsubishi single-point distributor, Mitsubishi dual-point distributor, or Mitsubishi electronic ignition system.

Other Data & Specifications - See appropriate Mitsubishi ignition system articles in DISTRIBUTOR & IGNITION SYSTEMS section.

IGNITION COIL

1974-76 IGNITION COIL SPECIFICATIONS

Application	Resistance (Ohms)
Primary	1.5
Secondary	9000

1977-78 IGNITION COIL SPECIFICATIONS

Application	Resistance (Ohms)
Primary	
B1800 & Calif. GLC	1.5
Federal GLC	1.3
Secondary	
B1800 & Calif. GLC	9000
Federal GLC	13,500

1979 IGNITION COIL SPECIFICATIONS

Application	Resistance (Ohms)
Primary	
GLC	1.3
626	1.5
B2000	0.9
Secondary	
GLC	13,500
626	9000
B2000	7000

FUEL SYSTEMS

CARBURETORS

CARBURETORS

Application	Model
All Models	Hitachi or Nikki (Stromberg) 2-Bbl.

Other Data & Specifications - See appropriate Hitachi or Nikki (Stromberg) Carburetor article in FUEL SYSTEMS section.