

Zenith Carburetors

ZENITH - STROMBERG 2-BARREL

Mazda 1200 (1972)

Application

Hitachi Part No.

All 1611 13 600A

DESCRIPTION

Carburetor is a two barrel downdraft design with primary and secondary systems. Primary circuits consist of idle, main metering, power valve, accelerator pump and idle transfer. Secondary circuits consist of idle transfer, main metering and power valve. Choke opening is manually controlled. Secondary throttle opening is mechanical. A deceleration valve is used to control exhaust emissions during engine deceleration.

ADJUSTMENT

IDLE RPM & MIXTURE

- 1) With engine at normal operating temperature, adjust curb idle screw to obtain 700-750 RPM.
- 2) With aid of an exhaust gas analyzer, adjust idle mixture screw to obtain a CO level of 2.5-4.0%. *NOTE - Mazda vehicles have an air cut valve which must also be adjusted to obtain the correct CO level.*

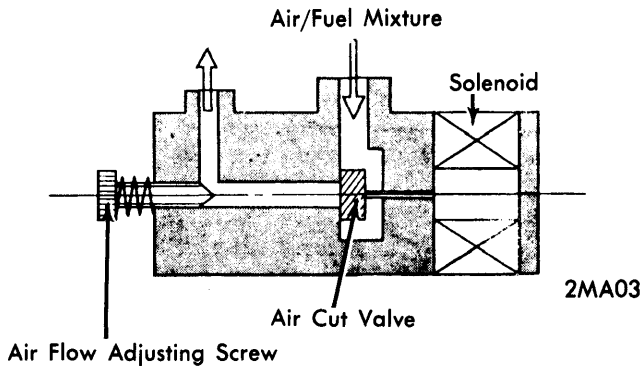

MAZDA AIR CUT VALVE CROSS SECTION

FLOAT LEVEL ADJUSTMENT

Mazda 1200 - Remove air horn and turn upside down. Measure float level clearance as shown in illustration. To adjust, bend float seat lip. Raise float by hand and measure clearance gap between needle valve and float seat lip. To adjust, bend float stopper.

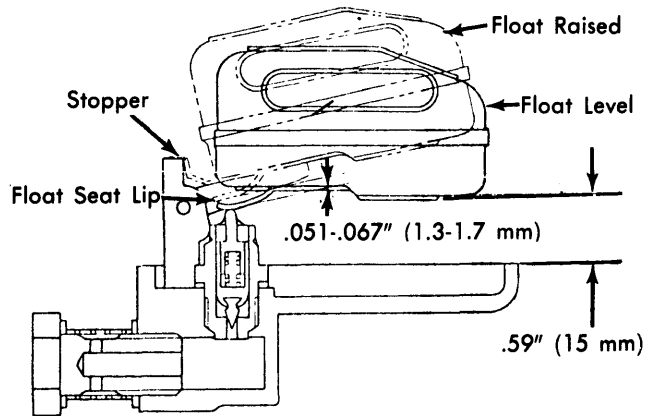

MAZDA FLOAT LEVEL SETTING

CHOKE ROD ADJUSTMENT

Mazda 1200 - When choke valve is completely closed, primary throttle valve opens 18° by action of choke connecting rod. Clearance between primary throttle valve and carburetor throat should be .064" (1.59 mm). To adjust, bend choke connecting rod to obtain correct clearance.

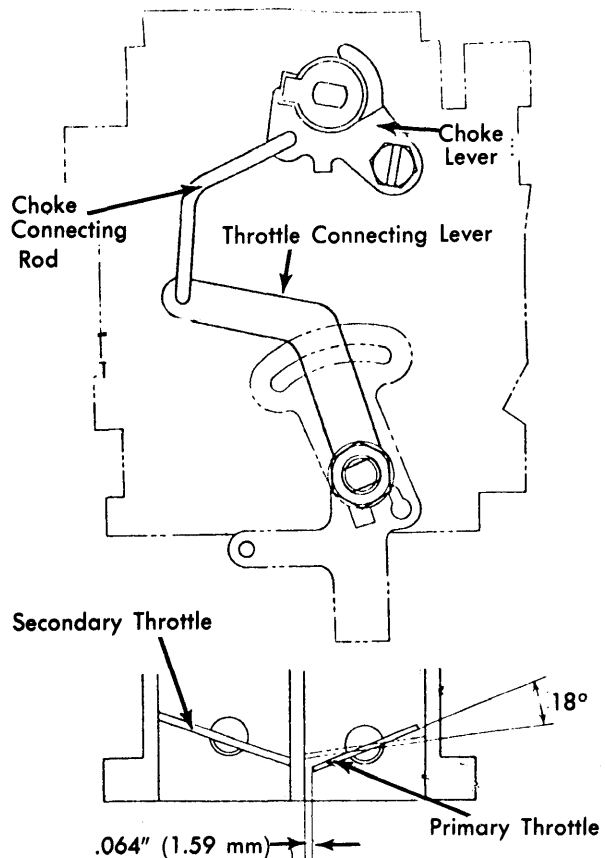

MAZDA CHOKE ROD ADJUSTMENT

Zenith Carburetors

ZENITH - STROMBERG 2-BARREL (Cont.)

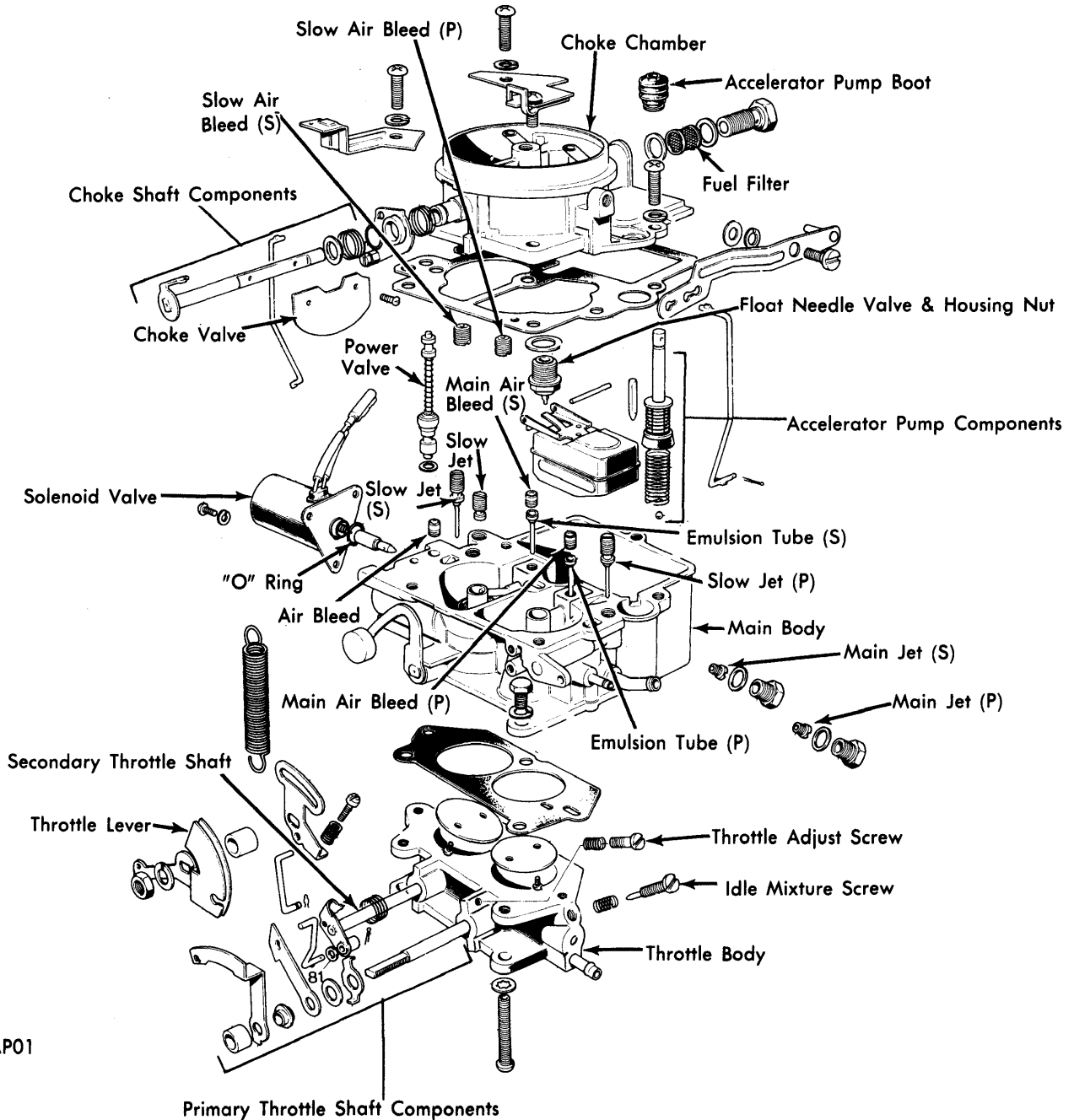

1MAP01

(S) = Secondary System
(P) = Primary System

MAZDA CARBURETOR EXPLODED VIEW

Zenith Carburetors

ZENITH - STROMBERG 2-BARREL (Cont.)

SECONDARY CONNECTING ROD ADJUSTMENT

Mazda 1200 - Secondary throttle begins to open when the primary throttle opens about 47°. Open primary throttle until end of groove in connecting lever comes in contact with connecting rod. Check clearance between throttle valve and bore. Adjust clearance by bending connecting rod.

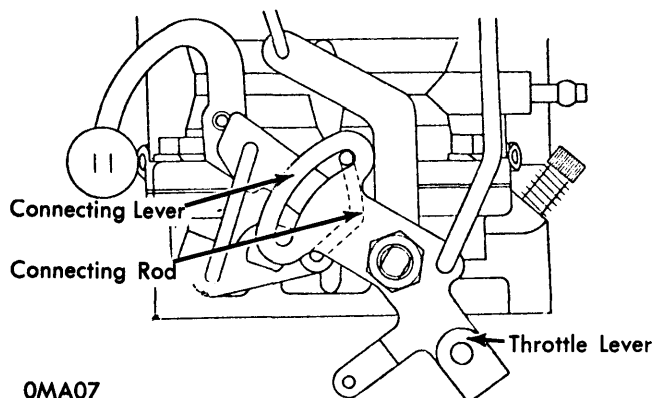

OMA07

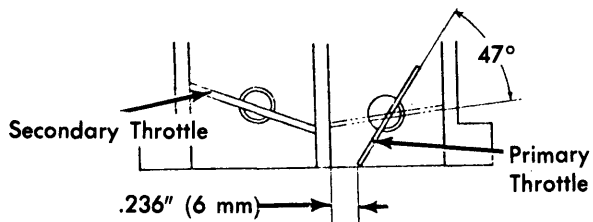

SECONDARY THROTTLE LEVER ADJUSTMENT

OVERHAUL

DISASSEMBLY

1) Remove throttle valve return spring. Remove screw, pump lever and connecting rod. Remove air horn attaching screws, lift air horn from body and disconnect choke connecting rod from connecting lever.

2) Remove slow air bleeds from air horn. Remove float and pin, then remove clip wire, needle valve, spring and spring retainer. Remove air horn to body gasket, and remove inlet check ball and spring from accelerator pump bore.

3) Remove outlet valve, slow jets and main air bleeds. Remove power valve using a suitable removing tool (49 0118 870A). Remove bolts attaching throttle chamber to body, and separate chamber from body.

4) If necessary, remove screws attaching throttle valves and auxiliary valve to shaft, and remove valves and shafts. **NOTE** - Manufacturer does not recommend removal of valves and shafts unless replacement is required.

INSPECTION

Thoroughly clean and dry all parts. Blow out all passages of carburetor carefully. Inspect all parts for wear, cracks, or other damage. Check jets for a clogged condition. **NOTE** - Do not use a wire to clean jets. Check float for leaks, and float needle and valve seat for wear.

REASSEMBLY

To reassemble, reverse disassembly procedure and note the following: When installing throttle valve, take care to eliminate gap between throttle valve and wall.