

Zenith Carburetors

ZENITH NDIX 2-BARREL

PORSCHE 4-CYL.

356 B/1600 (1959-63)
356 B/1600S (1959-63)
356 C/1600C (1963-65)

DESCRIPTION

Carburetor is of two-barrel downdraft design and consists of three main components: Throttle valve assembly, float chamber, and carburetor cover. The carburetor incorporates a piston type accelerator pump. No cold start or choke device is utilized. Dual floats are incorporated in the float chamber to insure proper fuel level under all engine operating conditions.

OPERATION

Idling

The mixture supplied to the engine under idle conditions is determined by the idle jet, idle air jet and the idle mixture screw. Fuel from the float bowl is taken by the idle jet and mixed with air from the idle air jet. This mixture flows to the mixture chamber, past the idle mixture screw, just below the throttle valve. At this point additional air entering through the throttle valve mixes with the mixture and is supplied to the engine.

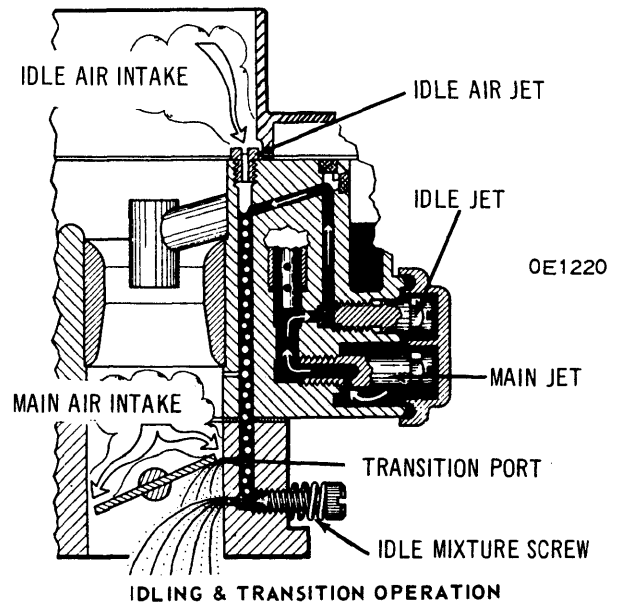

Transition

Just above the throttle valve there are additional orifices which deliver fuel when the throttle valve is opened. This provides a smooth transition from the idling to the main jet circuit.

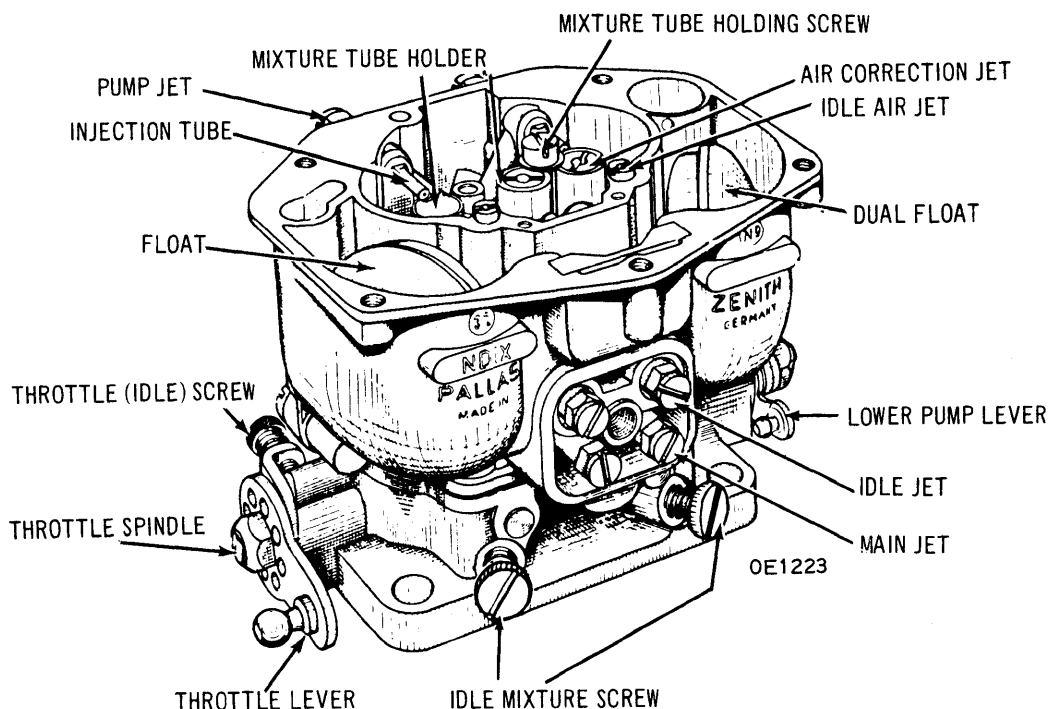

ZENITH 32 NDIX 2-BARREL CARBURETOR

ZENITH NDIX 2-BARREL (Cont.)

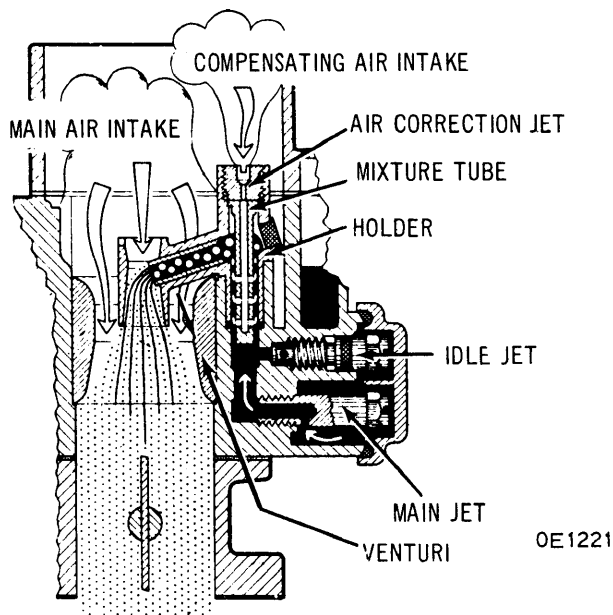

FULL THROTTLE OPERATION

Normal Operation

Fuel flows through main jets and as throttle valves are opened, intake vacuum acts on the jets and draws fuel to mixture tubes and then to the venturis. At this point air from the main air intake is mixed with the fuel and the fuel/air mixture is supplied to the engine.

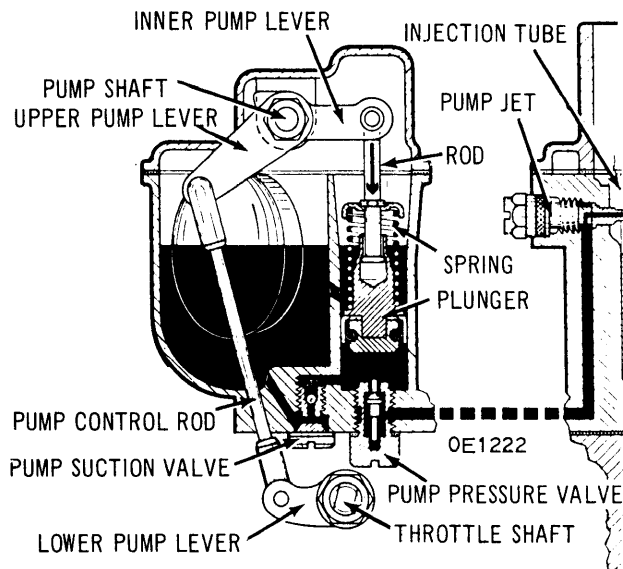

ACCELERATOR PUMP OPERATION

Accelerator Pump

Pump provides additional fuel to mixing chamber to provide the temporary enriched mixture which is necessary when throttles are opened suddenly during acceleration. The throttle and accelerator pump are connected by linkage which forces a plunger in the pump downward when throttles are opened. This forces fuel from the pump into pump jets and injection tubes. The fuel is then injected into the mixing chambers.

OVERHAUL

Disassembly

1) Remove spring clip and pressure spring at pump linkage and unhook linkage. Loosen cover retaining screws and carefully take off carburetor cover.

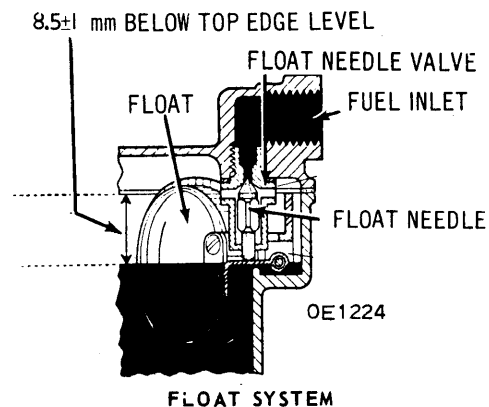

FLOAT SYSTEM

2) Remove float toggle lever, take out dual floats and remove retaining screw on mixture tube holder. Loosen air correction jets and pull out mixture tube holder.

3) Unscrew air correction jets and remove mixture tubes. Remove idling air jets and pump jets.

4) If necessary, remove injection tubes by using a screwdriver. **CAUTION** - Protect injection tubes and venturi with pieces of wood when performing this operation.

5) Release venturi clamping screw and lift out venturi. Remove jet chamber cover, main jets and idle jets. Remove idle mixture screws.

Cleaning & Inspection

Clean all components in gasoline and blow dry with compressed air. Do not use needles or wires to clean calibrated orifices. Check all components for wear or damage.

Assembly

To assemble, reverse disassembly procedure using new gaskets.

Zenith Carburetors

ZENITH NDIX 2-BARREL (Cont.)

ADJUSTMENT

Fuel Level

Fuel level may be checked without removing carburetor top cover when using fuel measuring glass tool (P-77).

1) Connect measuring glass tool to fuel outlet at float housing. Pour fuel into float housing. Use a 2.3 meter (7.6 ft.) high fuel column to obtain correct pressure.

2) Close off fuel supply and read fuel level. The correct level should be $.728" \pm .04"$ (18.5 mm \pm 1.0 mm) measured from edge of carburetor housing to fuel level surface.

Accelerator Pump

Hold a graduated container so that it may catch the fuel injected by the accelerator pump injection tubes. Press throttle lever twice from stop to stop. Check fuel quantity, empty container and repeat procedure. The quantity of fuel injected should be .2-.3 cc for every two strokes of lever. If necessary, adjust by lengthening or shortening pump rod by means of the turnbuckle.

Idle Adjustment

1) With engine at normal operating temperature and air filter removed, loosen carburetor levers from bellcranks.

2) Tighten idle adjustment screw on each carburetor (multiple installations) until engine speed is approximately 1000 RPM.

3) Fully close idle mixture screws and turn out 1½ turns. Adjust by screwing in or out until highest smooth running speed is obtained.

4) Loosen idle adjustment screws until idle speed of 650-750 RPM is achieved. Using a suitable balance meter synchronize throttle position of carburetors.

5) Pull out hand throttle to give 1200-1300 RPM and recheck synchronization with balance meter. Adjust throttle valve position if necessary and recheck idle speed with hand throttle released. Final idle should be 650-750 RPM.

CARBURETOR SPECIFICATIONS

NOTE - Numbers are stamped on parts for identification.

Venturi	
1600	24 mm
1600S	28 mm
Main Jet	
1600	#115
1600S	#130
Air Correction Jet	
1600	#230
1600S	#220
Idle Jet	
All	#50
Idle Air Jet	
1600	#120
1600S	#140
Pump Jet	
1600	#50
1600S	#40
Float Needle Valve	
All	#125
Mixture Tube	
All	#1S
Injection Quantity	
All	① .2-.3 cc
Float Level	
All	② $.728" \pm .04"$ (18.5 \pm 1.0 mm)

① - Two strokes per tube.

② - Measured with cover closed and test pressure of 1.8 meter water column.