

## WEBER ICF TYPE 1-BARREL

### FIAT

### Weber No.

850 Sedan		
100G. 000 Engine	.....	30 ICF
100G. 002 Engine	.....	30 ICF 7

OE1044

### DESCRIPTION

Single barrel downdraft carburetor incorporating a butterfly type choke valve and a diaphragm type accelerator pump. System also utilizes a "leaner device" to lean mixture at part throttle and to enrich mixture at full open throttle. Carburetor has separate normal running and idling systems.

### OPERATION

**Normal Running** – Fuel from the float chamber flows through main jet into emulsion tube well. Air from bleed jet and leaner device mixes with the fuel. Mixture is then advanced to the venturi, and into the engine.

**Idling** – Fuel from emulsion well is routed to idle jet. There it is blended with air from a calibrated bushing. It continues through a passage to the idle orifice and mixture screw. Fuel is then discharged into carburetor throat, downstream of the throttle valve. The passage that leads to the idle orifice also feeds an idle transfer port. This port, located upstream of throttle valve, enables engine to accelerate smoothly from idle.

**Leaner Device** – When throttle is only partly opened, a diaphragm which is operated by throttle spindle, opens passages to allow more air to be mixed with fuel. At full open throttle, diaphragm cuts off additional air supply and only the air bleed jet supplies air. This results in a richer mixture at full throttle.

**Accelerator Pump** – When throttle is closed, a lever raises plunger and causes fuel to be drawn from float chamber.

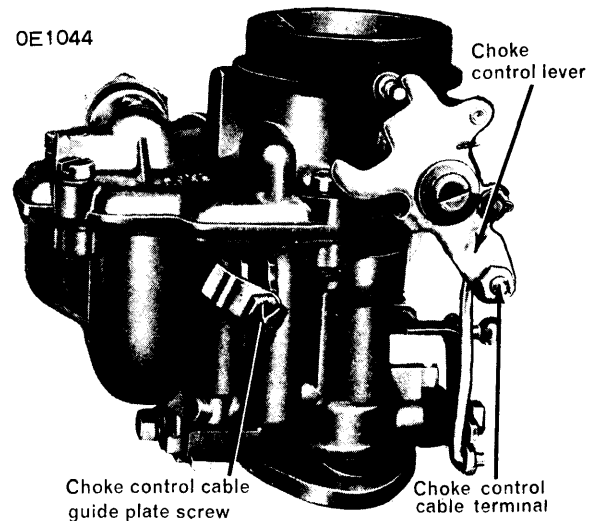

### EXTERNAL CHOKE CONTROLS

Fuel passes through ball valve into pump cylinder. When throttle is opened suddenly, plunger moves down under spring pressure and forces fuel through ball valve, through passage, to a calibrated pump jet. Jet injects fuel into throttle barrel to enrich mixture.

**Choke Device** – The closing of the choke butterfly valve causes intake manifold vacuum to draw fuel from discharge tubes. Because of lack of air through obstructed air horn, the mixture is quite rich and helps to provide quick starting of engine. When engine starts, increased vacuum causes throttle valve to open slightly. This provides mixture of suitable quality for engine to run properly even when cold.

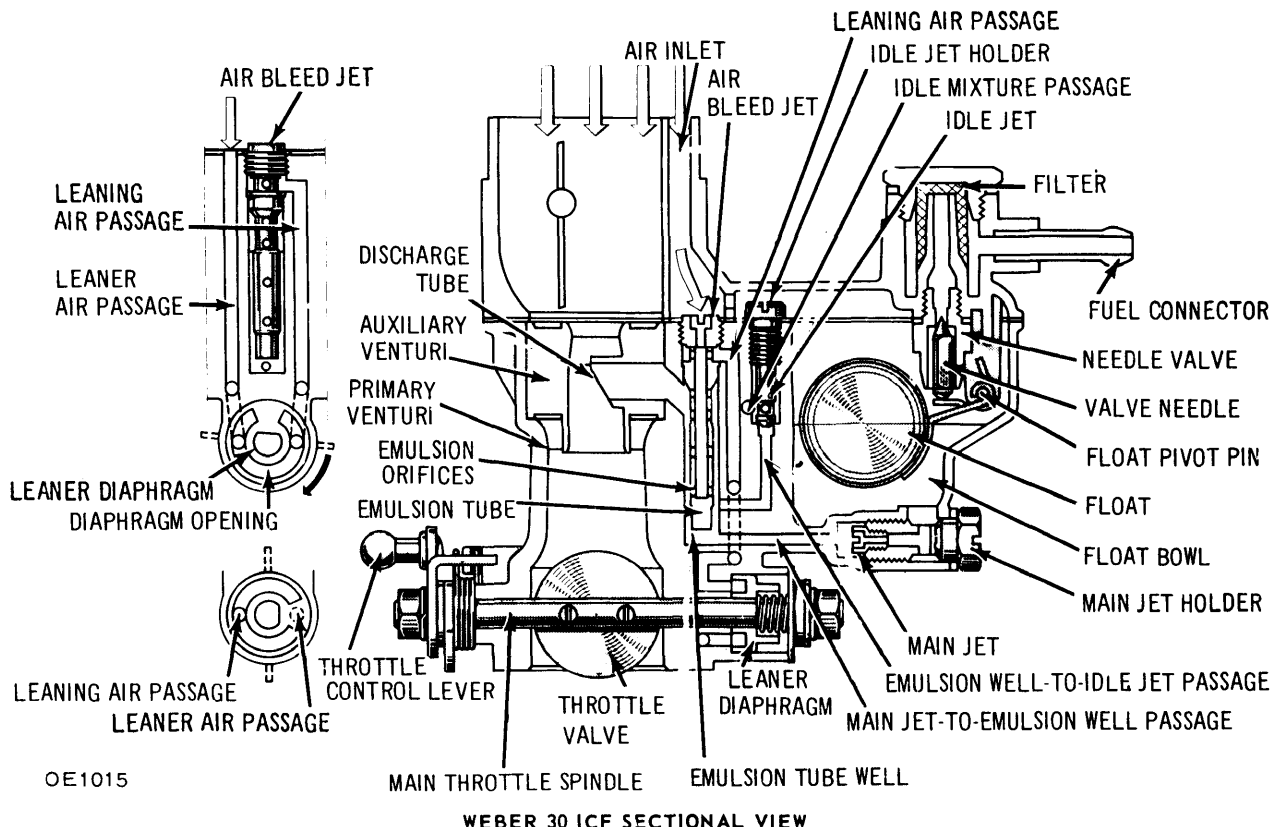

# Weber Carburetors

## WEBER ICF TYPE 1-BARREL (Cont.)

### ADJUSTMENT

**Float Level Adjustment** – 1) Remove carburetor body cover and make sure that needle valve is tight. Hold cover in vertical position so that weight of float does not lower ball in valve needle.

2) With float arm just touching ball, the float should be .276 in. (7 mm) from mating surface of cover. Leave gasket in place on cover when making this measurement.

3) If float is not in correct position, as specified above, bend float arms to obtain correct measurement.

**Idle Adjustment** – Make sure that engine is at normal operating temperature before adjustments are made. Adjust throttle stop screw so that engine runs smoothly. Turn mixture screw to achieve highest RPM. Turn throttle stop screw to best idle RPM. Repeat procedure with mixture screw and re-set idle RPM with throttle stop screw.

