

SOLEX 44 PHH/6 2-BARREL

ALFA ROMEO

2000 Roadster & Sprint 44 PHH

DATSUN

2000 Roadster 44 PHH

DESCRIPTION

Carburetor is twin body type sidedraft. The float chamber, acceleration pump, and cold start device deliver fuel equally to each throat of the carburetor. Construction is divided into five systems, as follows:

Slow Running – System supplies mixture for idling, slow and middle speed range running.

Main System – System supplies mixture when high power is needed in the middle and high speed ranges of running. Supplies fuel during acceleration and engine load conditions also.

Float System – Maintains fuel level at pre-set height when engine is running. Accurate metering of fuel is affected by level of fuel in this system.

Acceleration Pump – When throttle is opened suddenly, jets of this system supply extra fuel to prevent leaning of mixture.

Cold Start System – System allows for a richer mixture than normally is supplied. System does not utilize a choke valve.

ADJUSTMENT

Idle Speed & Mixture

1) Loosen throttle stop screws and adjust throttle valves to close completely. Return each mixture screw about one turn out from total close. Screw throttle stop screw in a little and start engine. Allow engine to reach normal operating temperature.

2) Set engine RPM to specified idling RPM by adjusting throttle stop screw. Then set to highest RPM by adjusting each mixture screw about ¼ turn.

3) After obtaining higher RPM, set to required idle RPM by adjusting throttle stop screws.

4) Repeat steps 2) and 3) two or three times until the required Idle RPM and quality can be obtained.

Accelerator Pump Rod

Three holes are provided for rod setting, located at end of pump rod. The hole in the middle is the standard setting. When increased delivery is required, use upper hole.

Float Level (Datsun 2000)

1) Remove jet chamber cover, jet block, and insert fuel level meter into hole after jet block removed. Place finger over hole at top of fuel meter and draw meter up slowly.

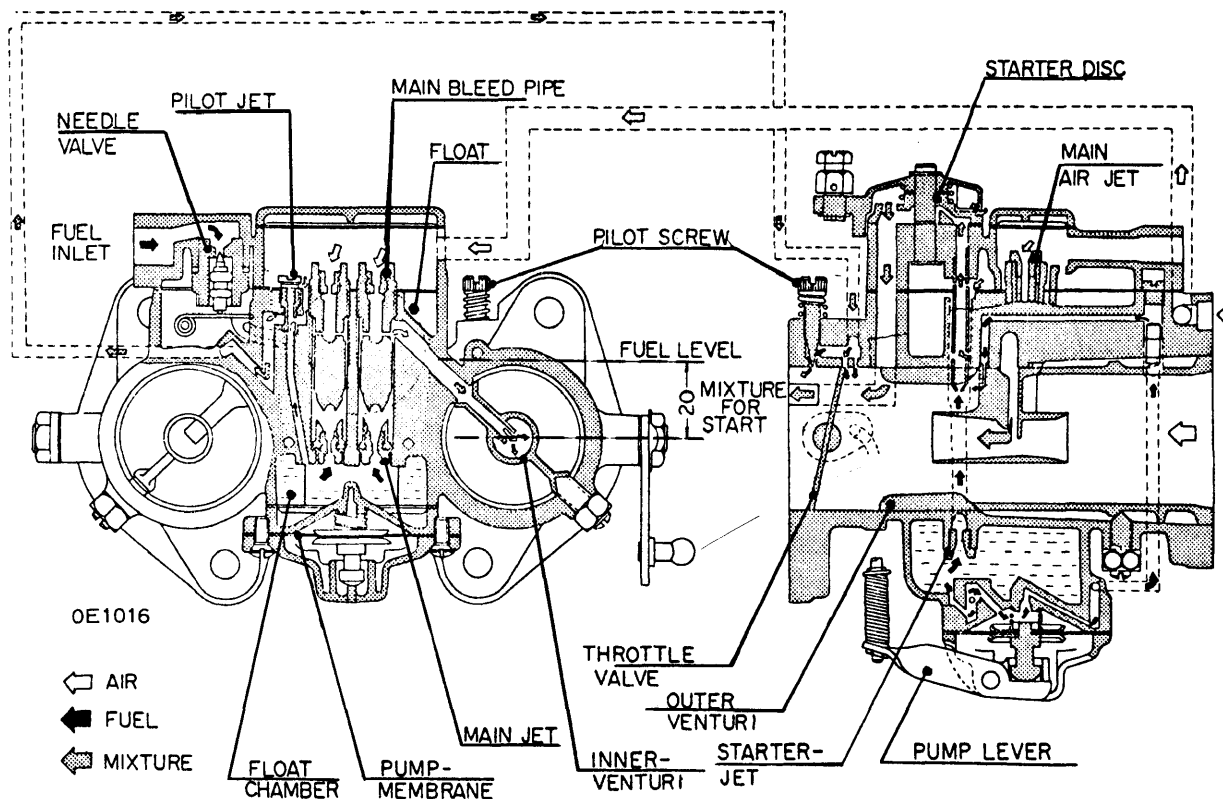

SOLEX PHH CARBURETOR (TYPICAL)

Solex Carburetors

SOLEX 44 PHH/6 2-BARREL (Cont.)

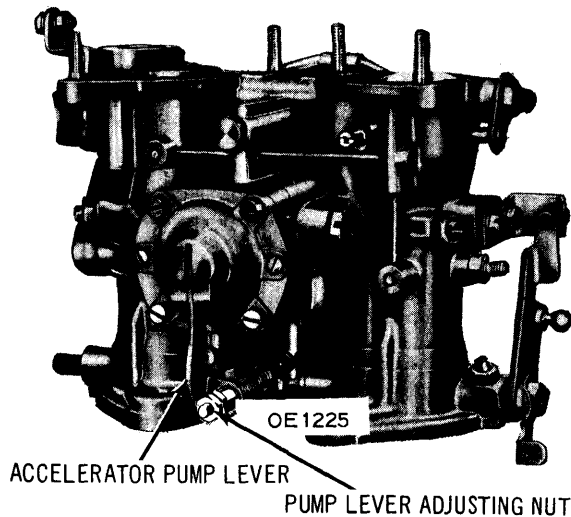

ACCELERATOR PUMP ADJUSTMENT
(ALFA ROMEO 2000)

2) Read fuel level on meter scale. Level (Dimension A in illustration) should be 18 ± 1 mm ($.7087 \pm .0394$ in.). Fuel level is 20 mm (.7879 in.) above center of main bore when fuel pressure is .25 kg/sq. cm. (3.55 lb./sq. in.).

3) Adjust level by replacing or removing packing of needle valve. By adding .5 mm (.0197 in.) thickness packing, fuel level will lower by 2 mm (.0788 in.). By removing .5 mm thickness packing, fuel level will raise by 2 mm. Standard packing is 1.0 mm (.0394 in.). Packings are available in .5 mm (.0197 in.) and 1.5 mm (.0591 in.) thicknesses.

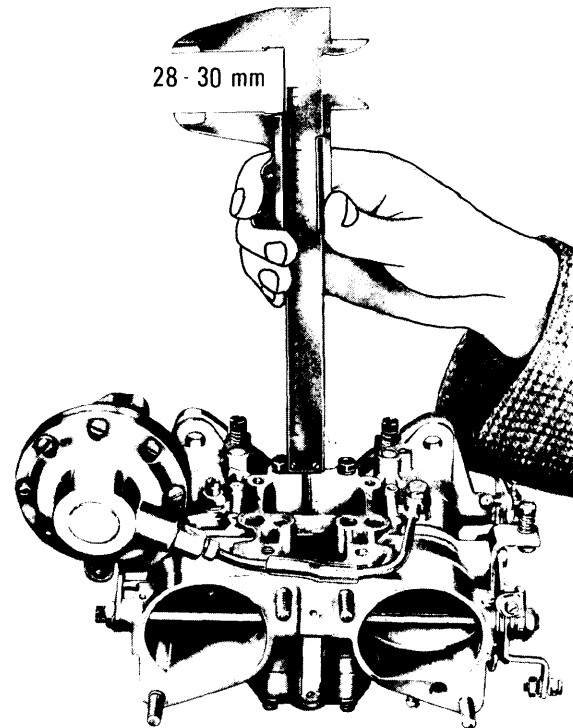

OE1018

44 PHH FLOAT LEVEL ADJUSTMENT
(ALFA ROMEO 2000)

OVERHAUL

Carburetor Removal

Remove air cleaners, disconnect fuel lines, remove throttle cable or links, and remove cold start cable. Remove carburetor from intake manifold. Clean fuel line filter with compressed air. To install, reverse removal procedure.

CAUTION - Cover openings of intake manifold and carburetor to prevent dirt and foreign particles from entering ports.

Float Chamber Removal

Loosen four screws and remove chamber cover. Be careful not to damage float chamber packing. Float can be removed as a unit. To install, reverse removal procedure.

CAUTION - Do not bend float arm as this may change fuel level and adversely affect carburetor performance.

Needle Valve Removal

1) Use a 14 mm socket wrench to remove valve. Diameter of needle valve in millimeters is engraved on valve.

2) The standard thickness of packing is 1 mm (.0394 in.) at which fuel level is 20 mm (.7874 in.) above center of main bore. To raise fuel level, make packing thinner, to lower fuel level, make packing thicker.

3) After removing needle valve, remove fuel joint and clean with compressed air. To install, reverse removal procedure.

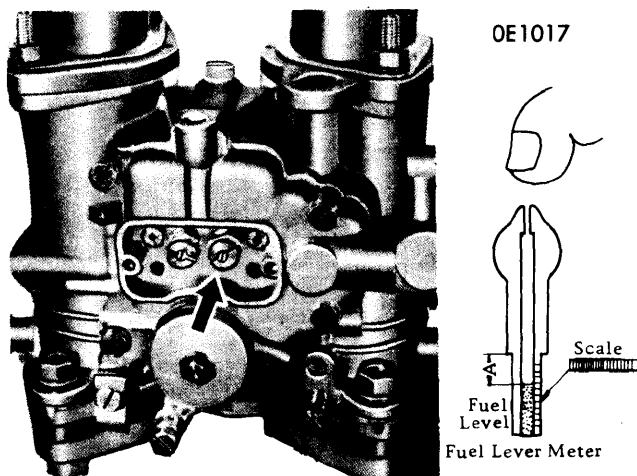

44PHH FLOAT LEVEL ADJUSTMENT
(DATSUN 2000)

Float Level (Alfa Romeo 2000)

Run engine for a short time to fill float chamber. Remove chamber cover and check that fuel level is 28-30 mm below cover mating surface. If fuel level is higher or lower, bend float arm.

SOLEX 44 PHH/6 2-BARREL (Cont.)

Jet Removal

Remove jet chamber cover, remove main air jet and pull jet block out. Remove main jet from jet block with screwdriver while holding head of jet block with a 10 mm open end wrench. Remove pilot jet. Clean jets in gasoline and blow dry with compressed air. To install, reverse removal procedure.

CAUTION – Do not use wires or pins to clean jets or calibrated orifices, as this may alter the metered flow of those parts.

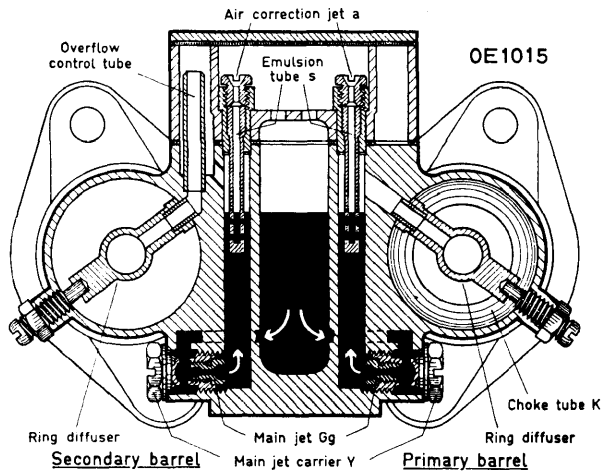

JET ASSEMBLY (44 PHH)

Accelerator Pump Removal

Remove cotter pin, washer and spring. Remove 6 screws. Lever, pump cover, diaphragm, return spring may now be removed. Check working condition of check ball and pump weight by swinging pump body and listening for sound of check ball. Remove float chamber cover for access to check ball and pump weight. Remove plug screw and remove ball and weight. To install, reverse removal procedure.

Cold Start Pump Removal

Remove snap ring, cover and disc. Check that surfaces of disc and carburetor body are not scratched. Starter jet is common to air jet. Adjust starter jet for proper starting and first idling.

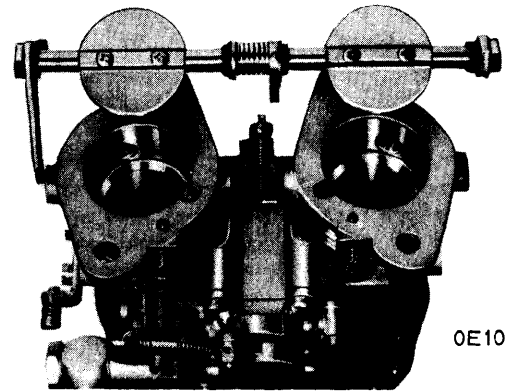

OE1019

44 PHH THROTTLE VALVE & SPINDLE ASSEMBLY

Throttle Valve & Shaft Removal

Remove shaft nut using one 12 mm wrench and one 14 mm wrench. Use care not to twist shaft. Remove caulking from throttle valve set screw using a file. Remove screw. Remove snap spring, pull snap pin out, then shaft can be pulled out. To install, reverse removal procedure. Use care not to lose dust seal. Caulk throttle valve set screws after tightening.

Inner & Outer Venturi Removal

Loosen 10 mm nut and remove air funnel. Loosen the three nuts, remove inner venturi, remove outer venturi. To install, insert outer venturi, making sure that engraved area of inner diameter is toward air cleaner side. Make sure that tip of lock screw fits in recess of venturi. Insert inner venturi, making sure that small pump nozzle hole is on intake side. Put packing in and tighten screws. Screws must be tight to prevent loosening from engine vibration.

① CARBURETOR ADJUSTMENT SPECIFICATIONS (Alfa Romeo 2000)

Idle RPM	600-700
Idle Jet No.	50
Accelerator Pump Jet No.	50
Primary Main Jet No.	135
Secondary Main Jet No.	155
Float Needle Valve Diameter	2 mm
Primary Air Jet No.	180
Secondary Air Jet No.	140
Accelerator Pump delivery	6-8 cc/20 Strokes

① – Datsun 2000 specifications not available. Idle RPM is 700.