

SOLEX 40 PII-4 2-BARREL

PORSCHE 4-CYL.
356 B/1600 S-90 (1960-63)

DESCRIPTION

Solex 40 PII-4 is a two barrel downdraft type. As a result of low mounting, and 2 accelerator pump nozzles per carburetor no chokes are used. Accelerator pump is of a diaphragm type. Each barrel has an independent idle mixture and power metering system.

ADJUSTMENT

Accelerator Pump Adjustment

With air cleaners removed, work throttle lever to be sure no air bubbles show in fuel stream. Hold tube graduated in cubic centimeters at tip of nozzle. Rapidly move throttle lever two times from stop to stop. Injection quantity from each nozzle on two pump strokes should be .45 cc in summer, and .65 cc in winter. Check each nozzle in this manner. To adjust, reset adjustment nut on pump rod. If adjustment should not be possible due to lack of threads, place a spacer between pump lever and adjustment nut to gain additional travel. Injection quantity as well as the moment of injection must be the same on both carburetors.

Nozzle Adjustment

Jet of squirting fuel must not strike primary or main venturi. Fuel must pass through slit between carburetor throat and the opening throttle valve (see illustration). If adjustment is necessary, bend carefully and do not alter nozzle tip height.

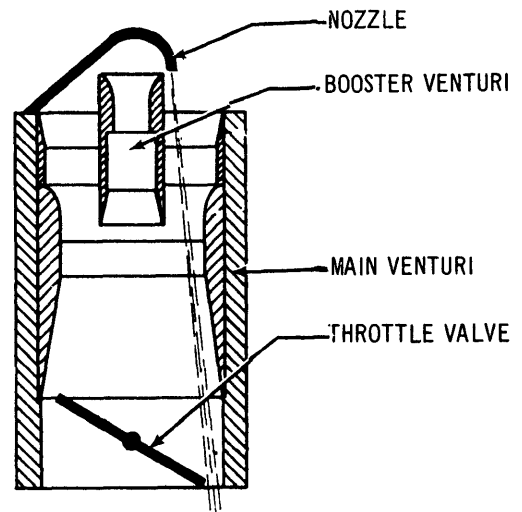

NOZZLE ADJUSTMENT

Float Level Adjustment

With car on level surface, remove main jet carrier. Install float level gauge (P-78) in place of carrier. With engine idling, float level should rise to a point between the two marks on gauge. Turn adjustment screw in to lower float level, and out to raise float level. If level gauge is not

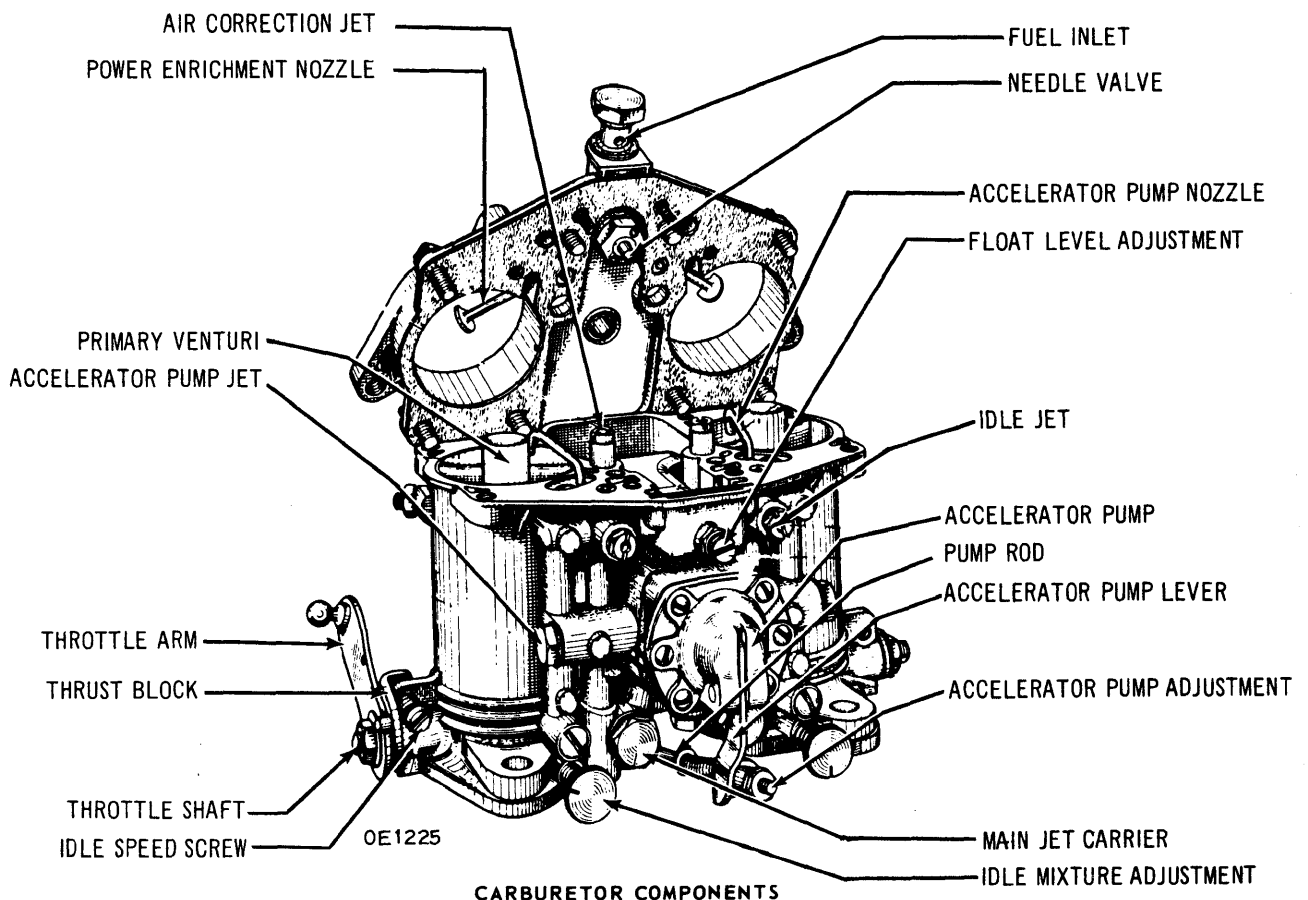

CARBURETOR COMPONENTS

Solex Carburetors

SOLEX 40 PII-4 2-BARREL (Cont.)

available, remove plug from float level inspection port. If float level is correct fuel can be seen, or will just begin to come out.

Idling Speed Adjustment

1) With engine at operating temperature, air cleaners removed, and throttle rods disconnected from throttle levers, uniformly turn idle speed screws in until the engine idles at 1000 RPM.

2) Following any convenient sequence turn idle mixture screws fully in on both carburetors, one at a time, being careful not to damage tips, then back out 1½ turns. From this initial adjustment position turn screws in or out until fastest idle is achieved.

3) Adjust idle speed screws on both carburetors until idle drops to 800-900 RPM. Place a suitable balance meter on carburetor. Turn adjustment screw on gauge so that plunger moves about halfway up tube and provides a reference point. No further adjustment should be made on gauge as it is now set for that particular engine.

4) Place gauge on second throat of same carburetor. Plunger should move up to same point on gauge. Should a different reading be obtained it will be necessary to resynchronize throttle valves. This is easily accomplished by slightly twisting throttle shaft.

5) Without changing gauge settings, place gauge on second carburetor and adjust throttle valve so that plunger in tube moves to same position as on first carburetor. If reading is not equal on both barrels, balance air flow by a slight, careful twisting of throttle shaft.

6) Should it be noted during adjustment procedure that idle RPM has changed, corrective adjustment must be made with idle speed screws. Recheck synchronization of carburetor.

7) When reconnecting throttle rods they must be adjusted so there is no tension on carburetor throttle lever.

OVERHAUL

Disassembly

1) Remove float chamber cover retaining screws and withdraw cover. Remove float pin, float, and intermediate swivel. Remove accelerator pump retaining screws and remove pump.

2) Remove main jet carriers with jets. Remove idle jets and idle air bleeds. Remove air correction jets and shake out emulsion tubes. Remove injection nozzle retaining screws and carefully withdraw nozzles making certain that nozzles are not bent.

3) Remove both pump jets and accelerating pump check valve. Remove enrichment jets. Remove idle mixture adjustment screws. Remove screws securing booster venturis, pull out venturis by twisting gently.

4) Remove screws securing main venturis, pull out main venturis by twisting gently and then carefully lifting out, making sure they do not bind. Remove burrs on main venturis caused by retaining screws.

Reassembly

Reassembly is in reverse order of disassembly but the following points should be observed:

Make certain accelerator pump diaphragm is in good condition. Check float for leaks. Use all new gaskets in reassembly. When installing main venturis make certain that writing is facing up so that it can be read from above. Do not overtighten venturi securing screws.

CARBURETOR SPECIFICATIONS

Main Jet	0115
Main Venturi	32
Air Correction Jet	180
Idle Metering Jet	57.5
Idle Air Bleed	1.8
Accelerating Pump	No. 72
Pump Jet	50
Accelerating Pump Nozzle	①
Float Needle Valve	175
Float Weight	7.4 Grams
Emulsion Tube	No. 25
Main Jet Carrier	6
By-pass Ports	1.7, 1.4, 1.0

① — High Type With 0.4 Restrictor.