

SOLEX PICT 1-BARREL

Volkswagen
 Type 1 (1962-72)
 Type 2 (1962-70)
 Karman Ghia (1962-72)

DESCRIPTION

Single barrel downdraft type carburetor equipped with an automatic butterfly type choke valve. The lower part of the carburetor houses the mixing and float chambers, the float and all jets. At the bottom of the mixing chamber, there is a throttle valve. The accelerator pump is of the diaphragm type and is located in a housing cast onto the float chamber.

OPERATION

AUTOMATIC CHOKE

Choke provides a rich mixture for cold engine and weakens the mixture gradually as the engine warms up. It increases idle speed as long as engine is not properly warm. At low temperature a bi-metal spring begins to uncoil and the movement is transmitted to the choke valve lever. This closes choke valve and engine receives a rich mixture. The movement of the choke valve shaft is transmitted to an operating lever which in turn moves the fast idle cam. When bi-metal coil is closed (cold position) the idle screw rests on the high step of the cam. During warm up and running conditions, fast idle cam turns and idle screw rests on progressively lower steps of the cam.

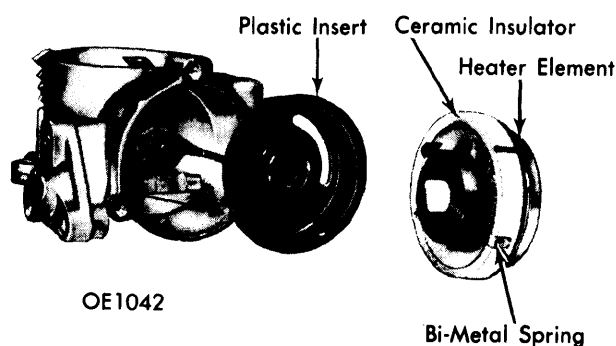

CHOKE UNIT

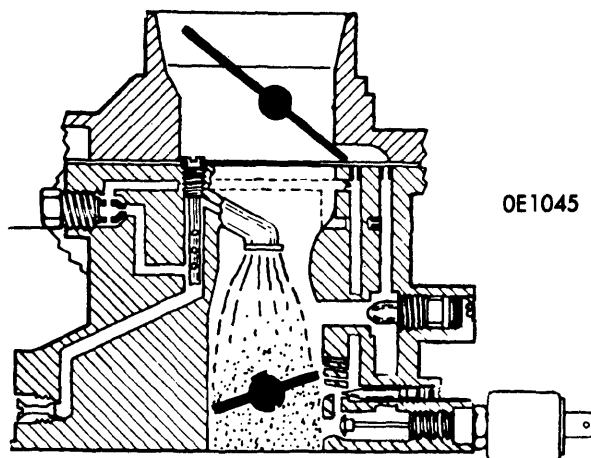

CHOKE OPERATION (1971-72)

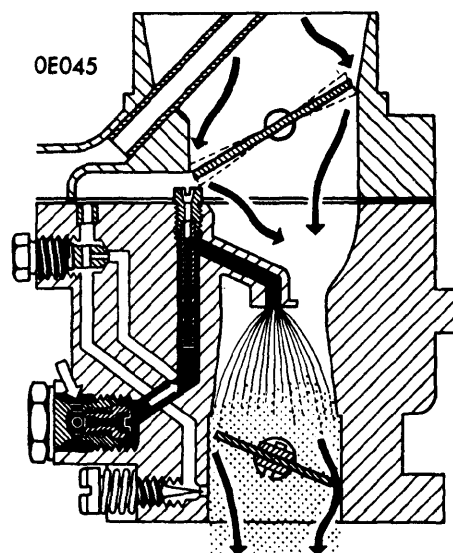

CHOKE OPERATION (1962-70)

IDLE OPERATION

Fuel from float chamber flows through main jet into a drilling which leads to idle jet. Air is drawn through idle jet air bleed above the jet. The mixture then passes through a drilled passage to the mixing screw and is discharged through an opening below the throttle valve. When throttle valve is opened slightly, the engine requires more fuel. The idle shut-off valve has been replaced by a by-pass air cut-off valve. This closes the by-pass port if the ignition switch is turned off, stopping the flow of air/fuel mixture.

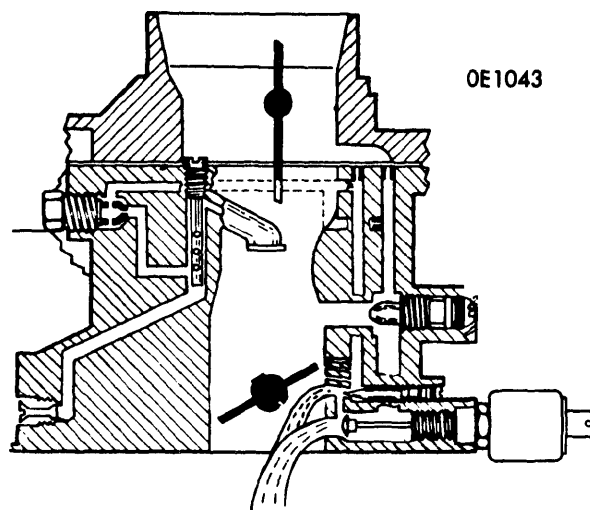

IDLING OPERATION (1971-72)

Solex Carburetors

SOLEX PICT 1-BARREL (Cont.)

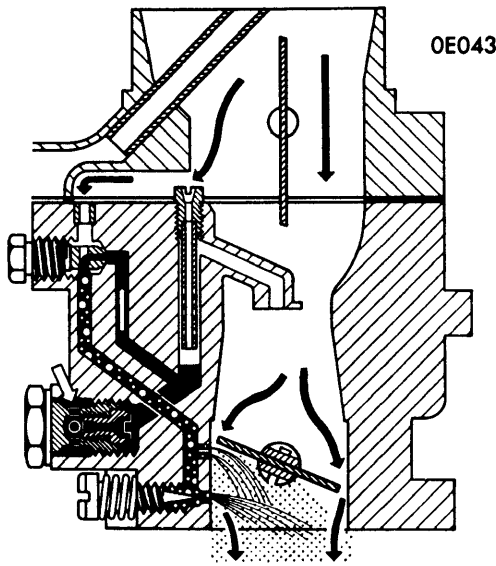

IDLING OPERATION (1962-70)

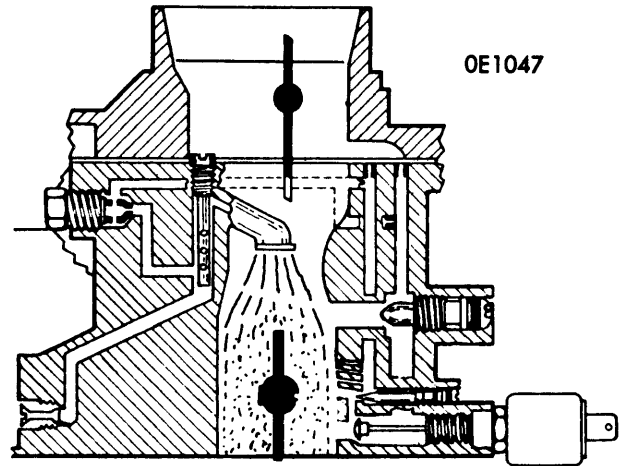

POWER FUEL FEED (1971-72)

NORMAL OPERATION

Vacuum in the intake passage draws fuel out of spray arm. This arm is connected to a vertical well which contains an air correction jet with emulsion tube pressed into it. Fuel flows to the well from float chamber via the main jet. As fuel level in emulsion tube drops, air is drawn in through correction jet. This air passes out of the holes in the emulsion tube and mixes with fuel from the main jet.

POWER FUEL SYSTEM

System provides a richer mixture at high speed full throttle operation. A calibrated fuel tube is pressed into upper part of carburetor and connects to float chamber via a drilling. The tube opens above the discharge arm in an area of reduced vacuum.

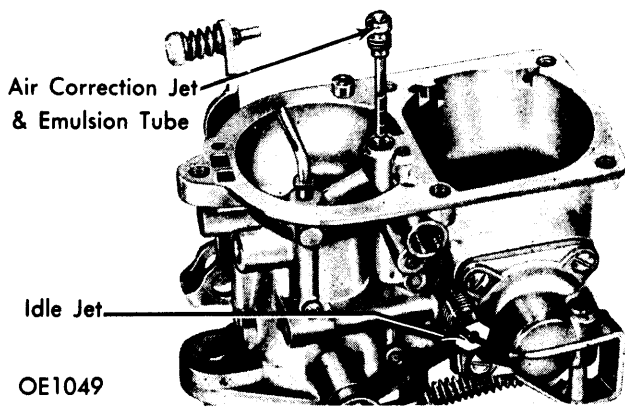

IDLE JET & AIR CORRECTION JET

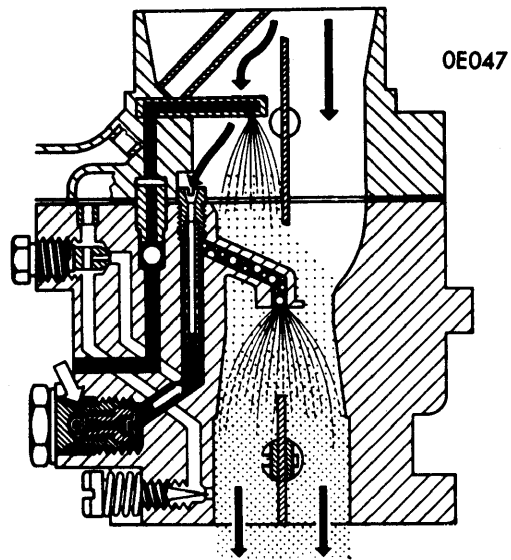

POWER FUEL FEED (1962-70)

ACCELERATOR PUMP

When throttle valve is opened, the movement is transmitted to a diaphragm through the linkage. The pressure stroke of the pump opens a ball check valve in the delivery passage and fuel is forced through a calibrated discharge tube into the mixing chamber. Injection begins when throttle is opened and ends at throttle opening of approximately 30° opening angle.

OVERHAUL

CARBURETOR REMOVAL

- 1) Remove pre-heater pipe, crankcase breather pipe, loosen clamp screw and remove air cleaner. Remove fuel hose, vacuum hose and automatic choke cable.
- 2) Remove accelerator cable from throttle valve lever and take off spring, spring plate, and cable pin. Remove the two retaining nuts and remove carburetor.

Solex Carburetors

6-131

SOLEX PICT 1-BARREL (Cont.)

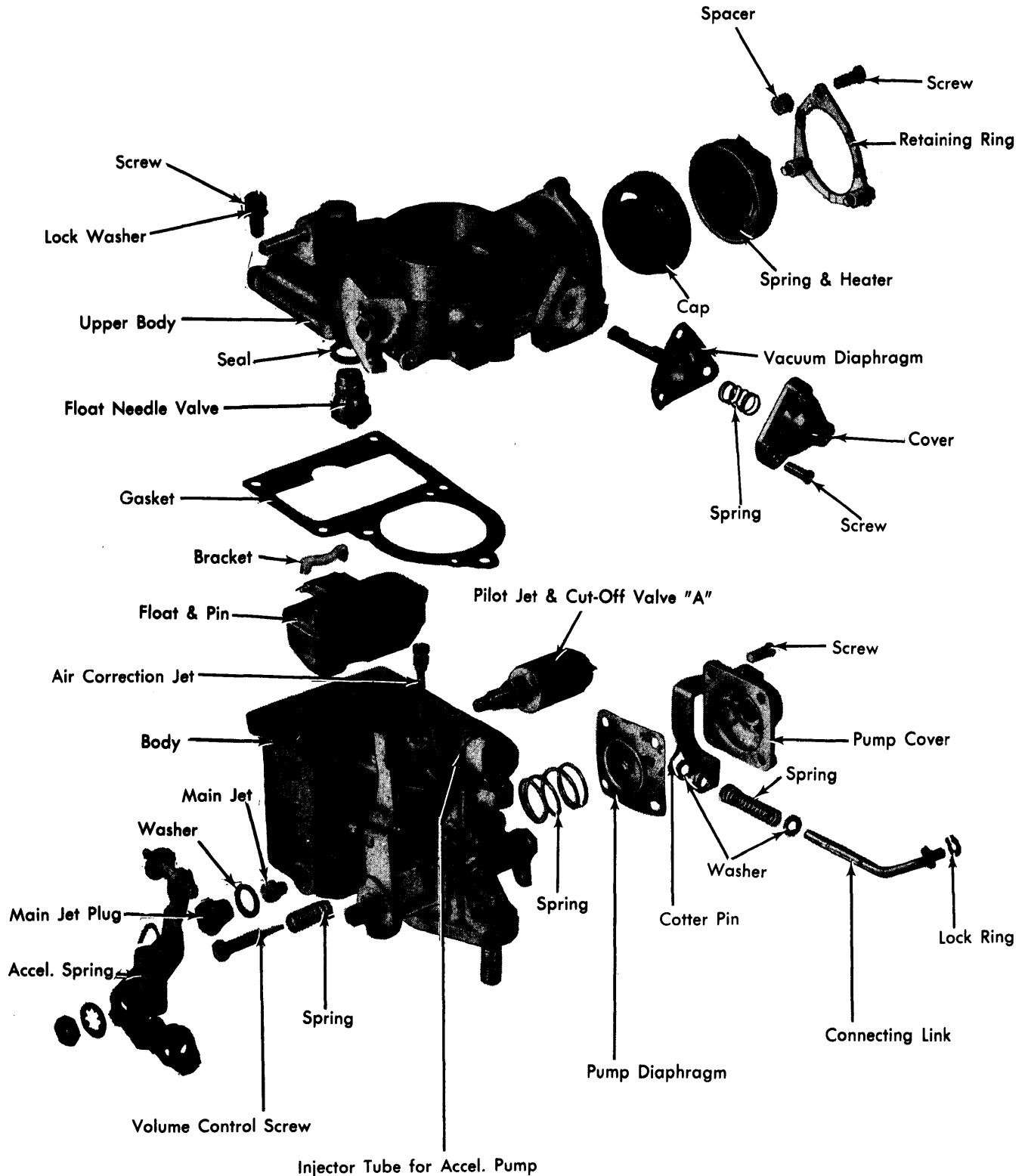

3VW011

SOLEX 30 PICT-2 CARBURETOR

Solex Carburetors

SOLEX PICT 1-BARREL (Cont.)

3) To install, reverse removal procedure, fitting new gasket on intake manifold. Make sure accelerator cable is attached so that there is 1 mm play between throttle valve lever and the stop on carburetor when accelerator pedal is fully depressed.

CARBURETOR DISASSEMBLY

- 1) Remove carburetor and unscrew the 5 top cover screws. Lift off the top cover and remove float. Unscrew float needle valve from top cover.
- 2) Remove 3 screws in automatic choke and take off retaining ring and spacers. Take off ceramic plate, bi-metal spring, heater element, and plastic cap.
- 3) Unscrew air correction jet with emulsion tube and idle jet. Unscrew main jet carrier with main jet and mixture screw.
- 4) Remove pump lever cotter pin from connector rod and remove 4 pump cover retaining screws. Take off cover, diaphragm and spring.

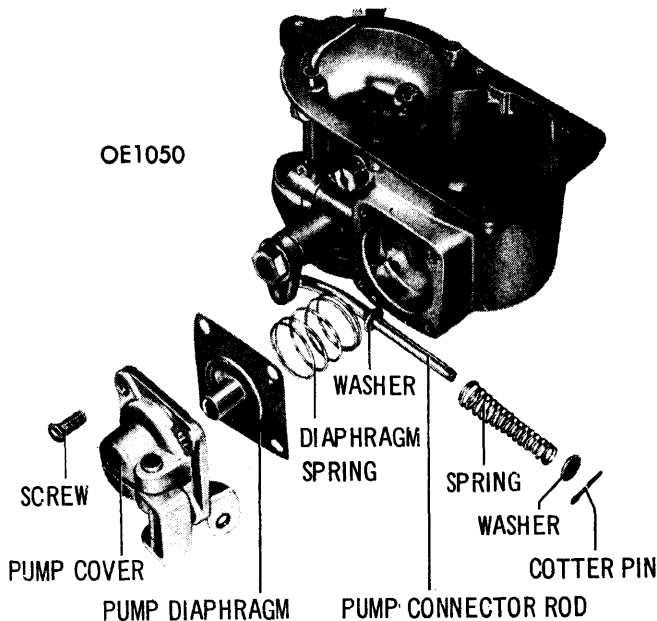

ACCELERATOR PUMP EXPLODED VIEW

ACCELERATOR PUMP DISCHARGE TUBE

Attach Tool No VW 646/1 clamp to discharge tube and tap end of tool with a hammer to remove. **CAUTION** — Do not turn tube when removing or installing.

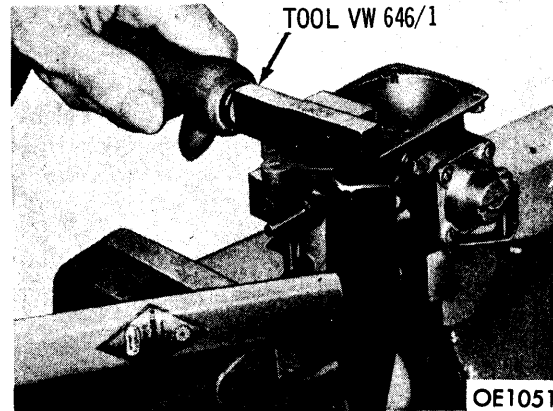

DISCHARGE TUBE REMOVAL

REASSEMBLY

To reassemble, reverse disassembly procedure. Check all parts for proper condition and operation before re-installing. Make sure that accelerator pump discharge tube spray direction is down past the throttle valve.



IDLE ADJUSTMENT

IDLE ADJUSTMENT

- 1) Bring engine to normal operating temperature before attempting any idle adjustments. Set idle adjusting stop screw to 700-800 RPM. Turn mixture screw in until engine speed begins to drop.
- 2) Turn screw out until engine runs smoothly. Then turn mixture screw out about 1/4 turn.
- 3) Check adjustment by opening and closing throttle suddenly. If engine continues to run, idle adjustment is correct. If engine dies, repeat idle adjustment procedures.

SOLEX PICT 1-BARREL (Cont.)

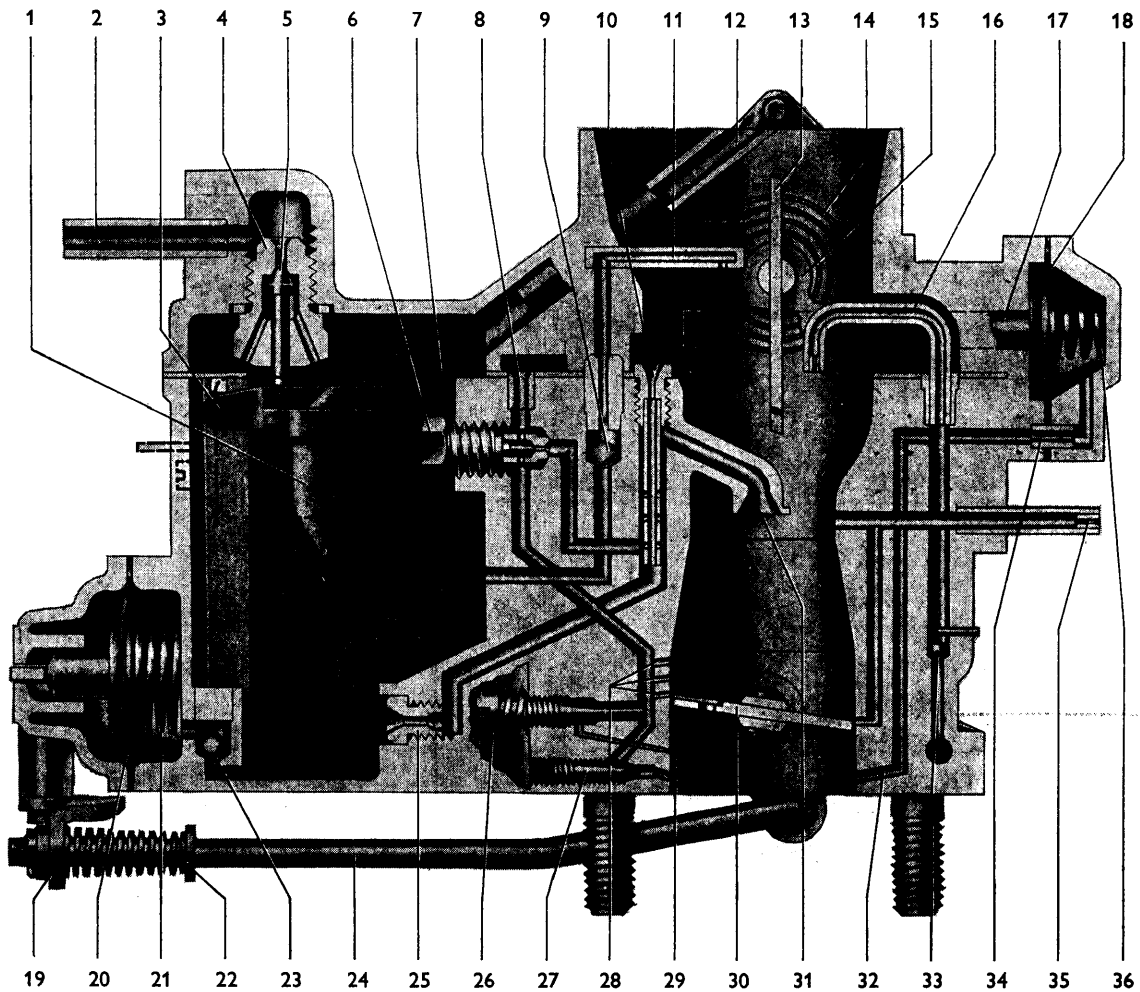

- | | | |
|--|---|---|
| 1 - Float | 15 - Operating Lever | 27 - Volume Control Screw
(Factory Preset) |
| 2 - Fuel Line | 16 - Accelerator Pump
Discharge Tube | 28 - By-Pass Ports |
| 3 - Float Lever | 17 - Diaphragm Rod | 29 - Idle Port |
| 4 - Float Needle Valve | 18 - Vacuum Diaphragm | 30 - Throttle Valve |
| 5 - Float Needle | 19 - Pump Lever | 31 - Discharge Arm |
| 6 - Pilot Jet | 20 - Pump Diaphragm | 32 - Vacuum Drilling |
| 7 - Gasket | 21 - Pump Spring | 33 - Ball Check Valve In
Accelerator Pump Drilling |
| 8 - Pilot Air Drilling | 22 - Spring | 34 - Jet In Vacuum Drilling |
| 9 - Ball In Power Fuel System | 23 - Ball Check Valve For
Accelerator Pump | 35 - Vacuum Connection |
| 10 - Air Correction Jet
W/Emulsion Tube | 24 - Pull Rod For Vacuum
Diaphragm | 36 - Spring For Vacuum Connection |
| 11 - Power Fuel Tube | 25 - Main Jet | |
| 12 - Float Chamber Vent Tube | 26 - Volume Control Screw | |
| 13 - Choke Valve | | |
| 14 - Bimetal Spring | | |

3VW12

SOLEX 30 PICT CARBURETOR (SECTIONAL VIEW)

Solex Carburetors

SOLEX PICT 1-BARREL (Cont.)

CARBURETOR ADJUSTMENT SPECIFICATIONS

A — Venturi Diameter (mm)
 B — Main Jet No.
 C — Idle Jet No.
 D — Air Correction Jet No.
 E — Idle Jet Air Bleed Diameter (mm) or No.

F — Pump Jet No.
 G — Power Fuel Jet Diameter (mm) or No.
 H — Float Needle Valve Diameter (mm)
 I — Float Weight (grams)
 J — Accel. Pump Volume per Stroke (cc)

Carburetor No.	A	B	C	D	E	F	G	H	I	J
28 PICT										
From Engine #5000.001	22.5	122.5	g 55	130y [ⓐ]	2.00	0.5	1.0	1.5	5.7	1.1 - 1.4 [ⓐ]
From Engine #0143 543	22.5	115	g 45	145y	1.55	0.5	0.7	1.5	5.7	1.1 - 1.4 [ⓐ]
From Engine #DO234015	22.5	122.5	g 55	150y	2.00	0.5	#75	1.5	5.7	1.1 - 1.4 [ⓐ]
28 PICT-1										
From Engine #5000 001	22.5	122.5	g 55	130y [ⓐ]	2.00	0.5	1.0	1.5	5.7	1.1 - 1.4 [ⓐ]
From Engine #0143 543	22.5	115	g 45	145y	1.55	0.5	0.7	1.5	5.7	1.1 - 1.4 [ⓐ]
From Engine #DO234015	22.5	122.5	g 55	135y	2.00	0.5	#75	1.5	5.7	1.1 - 1.4
28 PICT-2										
From Engine #5000 001	22.5	122.5	g 55	130y [ⓐ]	2.00	0.5	1.0	1.5	5.7	1.1 - 1.4 [ⓐ]
From Engine #0143 543	22.5	115	g 45	145y	1.55	0.5	0.7	1.5	5.7	1.1 - 1.4 [ⓐ]
From Engine #DO234015	22.5	122.5	g 55	135y	2.00	0.5	#75	1.5	5.7	1.1 - 1.4
30 PICT-1										
From Engine #F0000 001	24.0	125	g 55	125z [ⓐ]	1.50	50	ⓐ	1.5	5.7	1.3 - 1.6 [ⓐ]
From Engine #H0000 001	24.0	115	g 55	135z	1.50	50	#75	1.5	5.7	1.3 - 1.6 [ⓐ]
From Engine #B0000 001	24.0	120	g 60	135z	1.40	50	#50	1.5	5.7	1.3 - 1.6 [ⓐ]
30 PICT-2										
From Engine #F1462 682	24	x120	g 55	125z [ⓐ]	140	50	50	1.5	8.5	1.3 - 1.6 [ⓐ]
From Engine #HO879 927	24	x120	g 55	125z [ⓐ]	140	50	50	1.5	8.5	1.3 - 1.6 [ⓐ]
From Engine #HO204 001	24	x120	g 55	125z [ⓐ]	150	50	50	1.5	5.7	1.3 - 1.6 [ⓐ]
From Engine #HO874 200	24	x120	g 55	125z [ⓐ]	140	50	50	1.5	8.5	1.3 - 1.6 [ⓐ]
From Engine #H5000 001	24	x116	g 55	125z	140	50	60	1.5	8.5	1.3 - 1.6 [ⓐ]
From Engine #B5000 001	24	x116	g 55	125z	140	50	60	1.5	8.5	1.3 - 1.6 [ⓐ]
30 PICT-3										
From Engine #B6000 001 [ⓐ]	24	x122.5	65	125z	135	...	100	1.5	8.5	1.2 - 1.35
From Engine #B6000 002 [ⓐ]	24	x112.5	65	125z	135	...	100	1.5	8.5	1.2 - 1.35
From Engine #B5116437	24	x112.5	65	125z	135	...	100	1.5	8.5	1.2 - 1.35
From Engine #AE 000 001	26	x127.5	65	75z	135	...	100	1.5	8.5	1.45 ± 0.15
From Engine #AH 000 001	26	x127.5	65	75z	135	...	100	1.5	8.5	1.45 ± 0.15
From Engine #AK 000 001	26	x127.5	65	75z	135	...	100	1.5	8.5	1.45 ± 0.15

ⓐ — 1.2 - 1.3 cc before June 1963.

ⓑ — Transporter and Karmann Ghia use 145y.

ⓒ — Karmann Ghia use 170z.

ⓓ — Karmann Ghia only use #75.

ⓔ — Cotter pin in inner position.

ⓕ — Karmann Ghia used 135z.

ⓖ — 1.05 - 1.35 from Engine No. H1124670.

All use cotter pin in inner position.

ⓗ — Type 1 Manual Trans.

ⓘ — Type 1 Auto. Trans.