

Solex Carburetors

SOLEX 40 PDSI 1-BARREL

BMW 2002 (1973)

DESCRIPTION

This carburetor is a single barrel downdraft type. It is equipped with a butterfly valve type choke and a diaphragm type accelerator pump.

OPERATION

CHOKE

Manual choke operates by means of a cable. Automatic choke is operated by a bi-metal spring. When ambient temperatures are cold, accelerator pedal should be depressed briefly, so that tensioned bi-metal spring can close butterfly valve. Stop lever will rest on highest step of fast idle cam, which opens throttle valve. When car starts, a vacuum is created which draws fuel from float chamber through main jet into venturi. Choke valve is opened slightly against tension of bi-metal spring, by vacuum piston and piston rod.

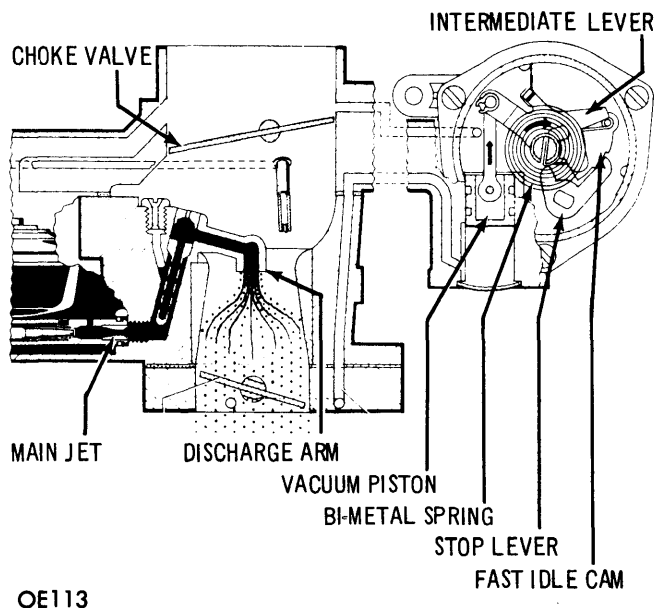

AUTOMATIC CHOKE SYSTEM

IDLING OPERATION

Fuel flows from float chamber through the main jet and a drilling to a pilot jet. Air enters through the pilot air bleed drilling (mixes with fuel) and forms an air/fuel mixture which passes to the idle mixture port by means of a drilling. The amount of mixture flowing through this port is regulated by a mixture control screw. By-pass ports, located near the throttle valve gap, help keep the engine running smoothly during transfer from idling to main jet operation.

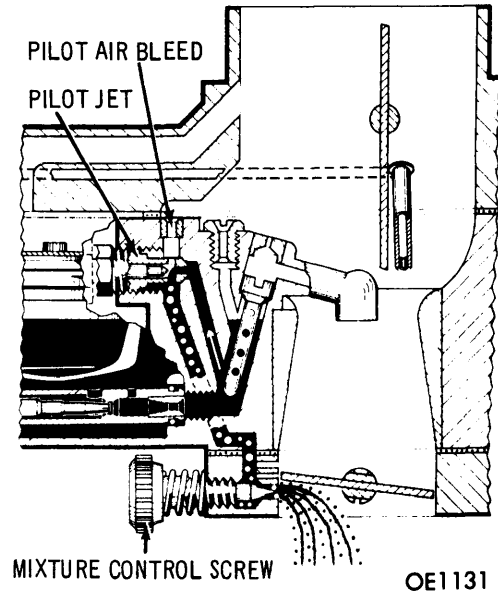

IDLE SYSTEM

NORMAL RUNNING

When throttle valve is open, vacuum from venturi, causes fuel to flow from float chamber into emulsion tube. Fuel in emulsion tube is converted into an air/fuel mixture and discharged into carburetor bore, through discharge arm. As engine speed increases air/fuel mixture increases.

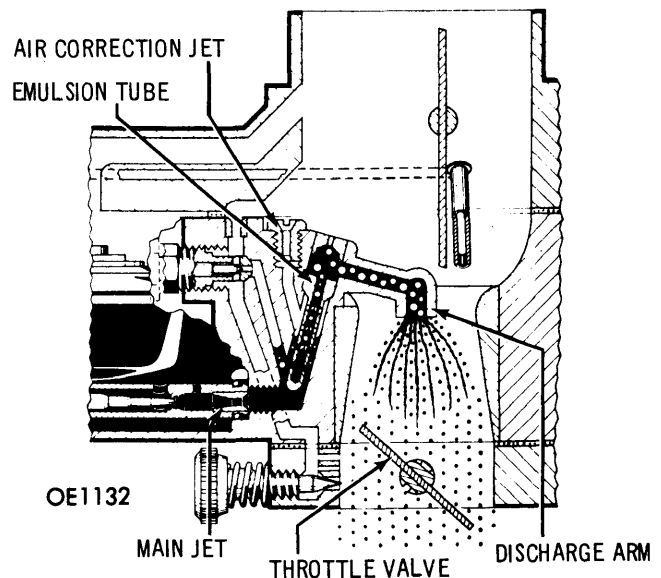

NORMAL OPERATION SYSTEM

ACCELERATOR PUMP OPERATION

When throttle valve is opened suddenly, air/fuel mixture becomes lean and must be enriched. For smooth operation during transition from low to high speed operation, a diaphragm pump is incorporated, to correct air/fuel mixture. This is accomplished by means of depressing a diaphragm, which compresses fuel, forcing it into carburetor bore through an injector tube.

SOLEX 40 PDSI 1-BARREL (Cont.)

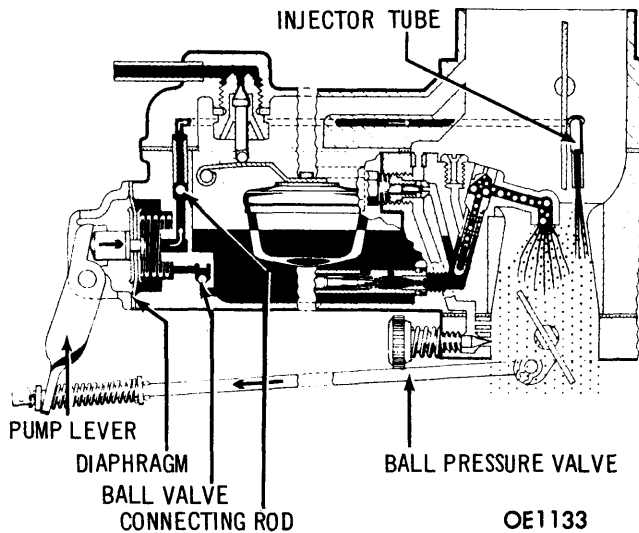

ACCELERATION SYSTEM

CHECKING & ADJUSTING

IDLE SPEED

NOTE — Adjust idle speed with engine at normal operating temperature and ignition timing and valve clearance properly adjusted.

Initially set idle speed to 800 RPM (± 100 RPM). Next, tighten or loosen idle mixture screw until engine runs erratically; this regulates the fuel. Adjust idle mixture screw until engine reaches maximum idle speed and runs smoothly. Adjust idle speed to 800 RPM (± 100 RPM). Reset mixture if necessary.

FAST IDLE ADJUSTMENT

Set fast idle speed to 2100 RPM (± 100 RPM), with engine warm. Actuate accelerator rod until the choke butterfly can be closed by hand. Close the butterfly to about .25" (6.5 mm). This brings the stop lever to the fast idle speed position. **DO NOT** actuate the accelerator rod again. Adjust to proper gap by turning nuts at the choke connector rod.

FUEL LEVEL

Allow engine to run for a short time. Stop engine and remove fuel hose. Remove carburetor cover and seal. Using suitable gauge, measure fuel level in float bowl. Measurement should be .7-.75" (17-19 mm). Adjustment is possible by means of a seal underneath float needle valve.

ACCELERATOR PUMP

1) Note direction of spray from discharge arm (see illustration). Carburetors with a single vacuum connection ("1") have a different discharge angle than those with two vacuum connections ("1" & "2"). To avoid jerks on acceleration from cruise, direction of spray must be set as shown on carburetor design "B". Secure loose discharge pipes with Loctite No. 90.

2) Remove carburetor and attach suitable test gauge. Fill carburetor and gauge glass with super grade fuel. Actuate butterfly 10 times, to full open position (make movements quickly and smoothly, with slight pause between each stroke).

3) From the gauge glass, read the amount of injected fuel. Divide this quantity by 10. The result should read 2 cc ($\pm .15$ cc) per stroke. If quantity injected is too small, screw in adjusting nut "1" (see illustration). If quantity is too large, loosen adjusting nut "1".

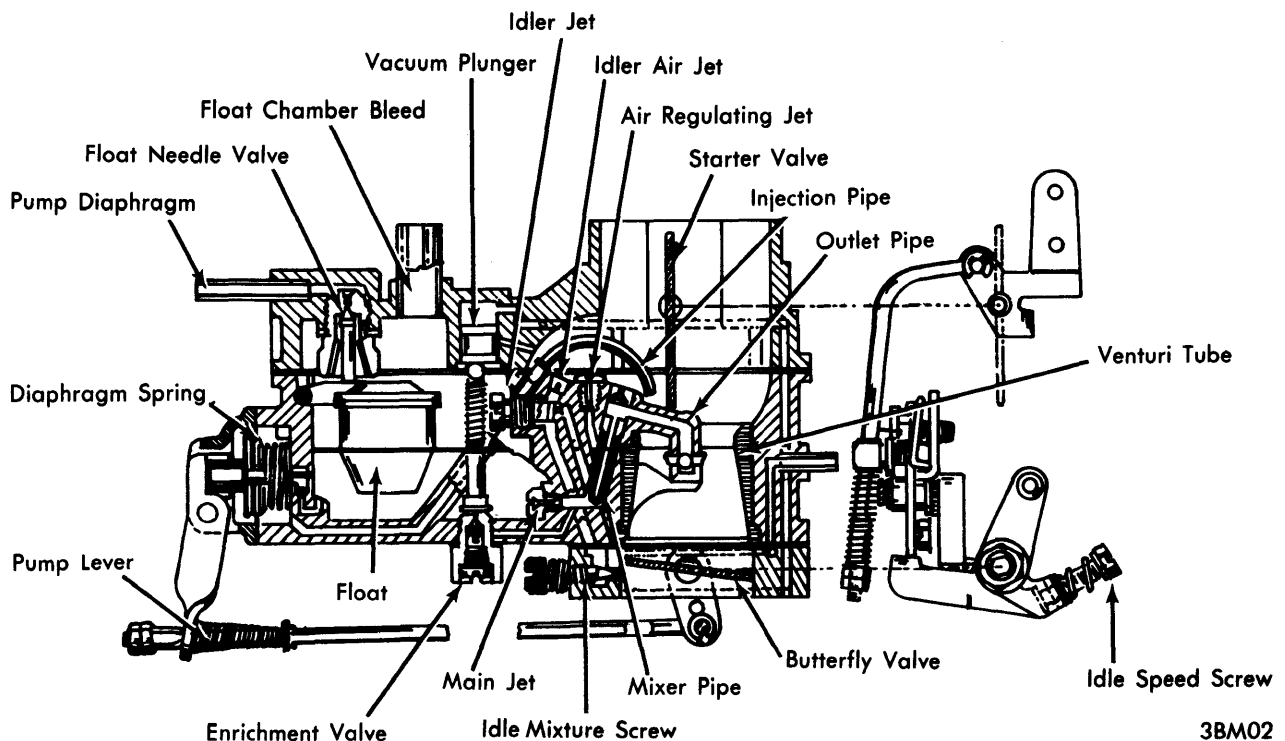

SOLEX 40 PDSI 1-BARREL CARBURETOR

Solex Carburetors

SOLEX 40 PDSI 1-BARREL (Cont.)

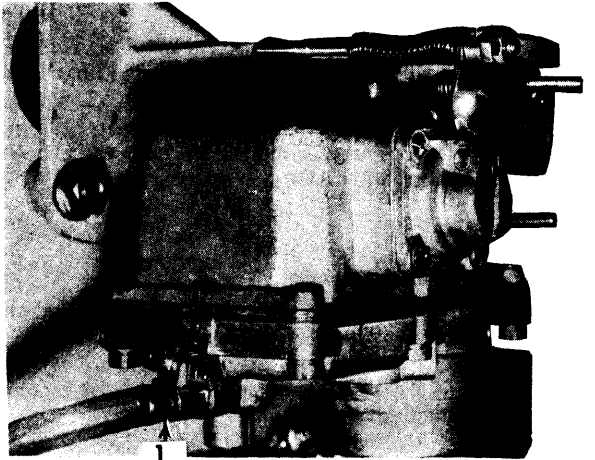

3BM01

ADJUSTING INJECTION QUANTITY

AUTOMATIC CHOKE

1) Ensure that choke butterfly shaft rotates easily. If necessary, lubricate with Molykote. The choke butterfly should remain closed if outside temperature is below 68°F. The notch on spring housing must coincide with peg on choke valve casing.

2) To adjust, remove spring housing with cover (leave water hoses connected). Press choke rod down to the stop. Check gap between edge of butterfly and carburetor throat, using a drill

or gauge rod. Adjust gap to .259" (6.6 mm) after loosening lock nut on underside of choke housing; then turn adjusting screw. Replace choke assembly.

OVERHAUL

DISASSEMBLY

Disconnect control rod between automatic choke and throttle valve. Remove float chamber cover, float needle valve, and float. Remove plug and main jet. Pull off accelerator pump jet (over acceleration pump). Unscrew idling jet and remove emulsion tube jet. Remove idle mixture screw. If so equipped, remove intermediate flange valve.

INSPECTION & CLEANING

Inspect all mating surfaces, direction of spray from injection tube, and all linkage. Clean parts in suitable solvent and blow parts and passageways dry with compressed air.

REASSEMBLY

Install spring, diaphragm and cover for accelerator pump. Insert accelerator pump jet. Screw in idling jet and emulsion tube jet. Screw in idling mixture screw until it bottoms out, then back out one turn. Screw in needle valve with its gasket and replace float bowl cover. Reconnect rod between automatic choke and throttle valve.

CARBURETOR ADJUSTMENT SPECIFICATIONS

Carb. No.	Idle Speed (Engine RPM)		Float Level Setting	Accel. Pump Setting	Choke Pulldown	Unloader Setting	Auto. Choke Setting	Dashpot Setting
	Hot	Fast						
SOLEX 40 PDSI	850-950	2100	.59-.67"	Neutral	9.8" Hg	.259" ①

① - Choke butterfly gap.