

# Hitachi Carburetors

## HITACHI S.U. TYPE 1-BARREL

Datsun 1500 Sports Car (1963-65)  
 Datsun 1600 Sports Car (1966-68)  
 Datsun 2000 Sports Car (1968-70)  
 Datsun 240Z (1970-72)

### DESCRIPTION

Hitachi S.U. type is a sidedraft carburetor. The venturi area is automatically changed according to engine air intake. Amount of fuel passing through main jet is governed by a tapered needle. Main components of carburetor consist of; A float chamber, suction chamber, suction piston, piston damper, metering needle and jet, and a throttle valve body.

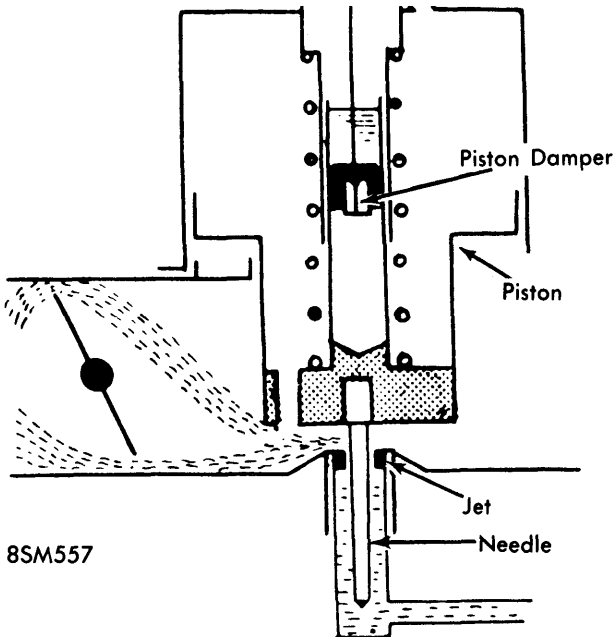

THROTTLE AT IDLE

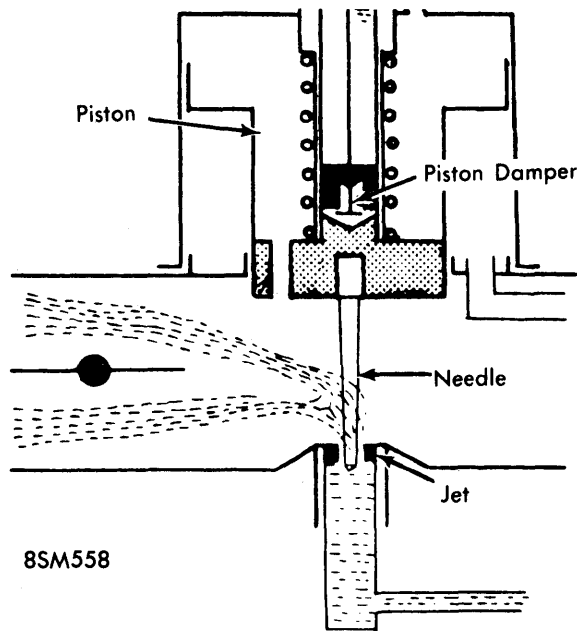

THROTTLE FULLY OPEN

### OPERATION

**Float Chamber** – Fuel passes through float needle valve and enters float chamber. Fuel level is governed by float and needle valve.

**Suction Piston** – Suction piston is located in suction chamber. Also fitted to piston is a damper to slow down piston movement. Fitted to bottom of piston is a metering needle, hence, when piston rises or drops, needle rises or drops in metering jet. As a result, piston movement regulates both air flow and fuel flow. When throttle valve is opened, this raises vacuum across venturi due to increased air flow, causing piston to raise and enlarge venturi area. The piston damper retards this movement, resulting in a richer mixture at this moment due to increased venturi vacuum. As a result, damper takes over the function of an accelerator pump in a conventional carburetor.

**Choke System** – When choke is pulled out, choke lever lowers main jet and opens throttle valve 6°. Lowering main jet creates a greater gap between needle and main jet, allowing a greater amount of fuel to enter venturi.

### MAINTENANCE

**Idle Speed & Mixture Adjustment** – Perform following adjustment with air cleaner removed, engine at normal operating temperature and with oil level in piston damper correct. Make certain that suction piston does not bind in suction chamber. Disconnect front and rear carburetors so they operate independently.

- 1) Connect tachometer and timing light, adjust idle speed to 600-700 RPM by turning front and rear throttle adjusting screws by equal amounts.
- 2) Using a suitable flow meter, adjust throttle screws so that air flow of each carburetor is balanced at 600-700 RPM. Make sure that ignition timing is correctly set to 5° BTDC (man. trans.) or TDC (auto. trans.).

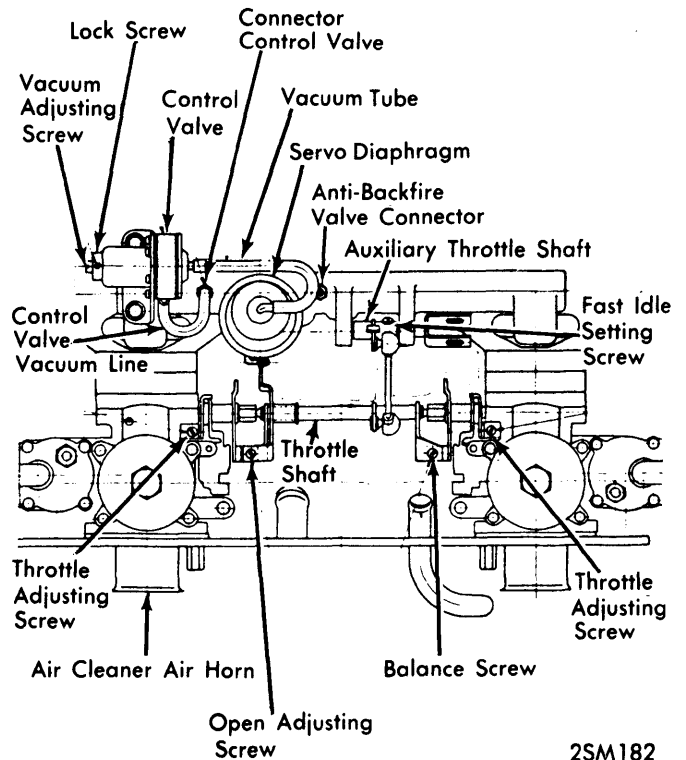

CARBURETOR & LINKAGE COMPONENTS

## HITACHI S.U. TYPE 1-BARREL (Cont.)

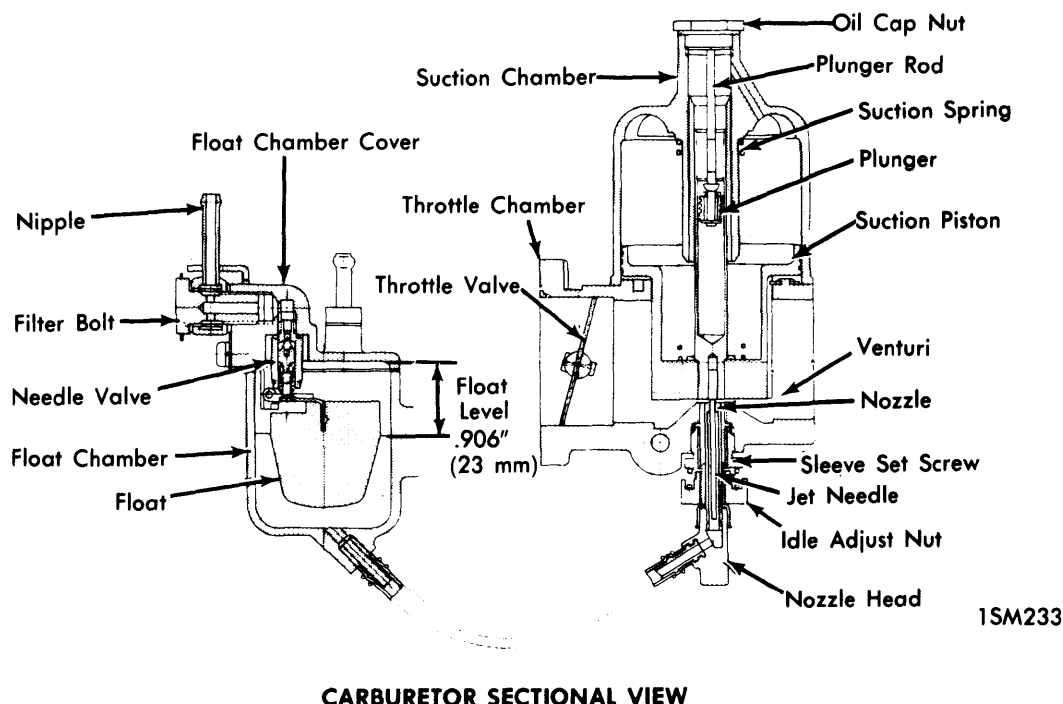

CARBURETOR SECTIONAL VIEW

3) If engine speed changes when adjusting timing to specifications, repeat adjustments in step 2).

4) Disconnect control valve vacuum line from control valve connector and connect servo diaphragm vacuum line to control valve connector. Engine idle speed should increase to 1200-1400 RPM.

5) Using flow meter, make sure that front and rear carburetor air volume is balanced. Race engine once to 3000 RPM and then adjust opener screw to 1700 RPM, then gradually turn screw to decrease speed to 1400 RPM.

6) Check CO level with air pump discharge hose disconnected. CO level should be 1.0-1.6% (man. trans.) or 0.6-1.2% (auto. trans.). If CO level is not as specified, turn front and rear idle mixture nuts clockwise, 1/8 turn at a time, until correct CO level is obtained.

7) Pull servo diaphragm vacuum line off control valve connector for just a moment and then reconnect to control valve. Engine speed should still be 1400 RPM.

8) Reconnect servo diaphragm vacuum line to control valve and connect control valve vacuum line to its original position. Recheck carburetor balance and make sure that idle speed is set to 750 RPM (man. trans.) or 600 RPM (auto. trans. in drive).

**NOTE** - Adjustment of idle mixture without use of CO meter is not recommended and should be avoided unless absolutely necessary.

**Mixture Adjustment Without CO Meter** - If CO Meter is not available, tighten mixture nuts of both carburetors completely up, and then loosen each nut three times. Tighten each nut simultaneously by 1/8 turn at a time. Continue

until engine speed is at highest RPM. This should be about 2½ turns out from fully up position. Check carburetor balance and make sure that idle speed is set to 750 RPM (man. trans.) or 600 RPM (auto. trans. in drive).

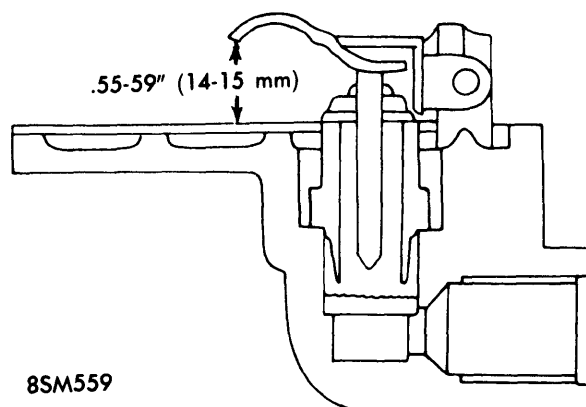

FLOAT SETTING

**Float Level Adjustment** - Remove and invert float chamber cover. Distance between float chamber cover and contact point of float lever should be .55-.59 in. (14-15 mm). Adjust by bending float lever.

**Piston Damper** - Check oil level in piston damper every 3000 miles, if necessary top it off. Oil level should not be below second groove in plunger rod. Use 10W-30 or 20W weight engine oil.

**Piston & Suction Chamber** - Disassemble and clean piston and suction chamber at least twice a year. **NOTE** - Always disassemble carburetors individually as parts should not be interchanged. To disassemble, proceed as follows:

# Hitachi Carburetors

## HITACHI S.U. TYPE 1-BARREL (Cont.)

1) Remove suction chamber securing screws, carefully lift off suction chamber. Remove spring, nylon washer and piston. **CAUTION** — Care should be taken not to bend needle or scratch inside of suction chamber or outside of piston.

2) Do not remove jet needle unless absolutely necessary. Should it become necessary to remove needle, loosen jet screw. Using pliers, grasp needle within .079 in. from shoulder and remove by pulling and turning slowly.

3) Incorrect setting of needle in piston will result in malfunctioning. Set needle in piston so that shoulder is flush with bottom of suction piston.

4) Wash suction chamber and piston with clean gasoline and dry with compressed air. Apply a few drops of light oil to suction piston rod. Do not oil inside of suction chamber or outside of piston. To reassemble, reverse above procedure.

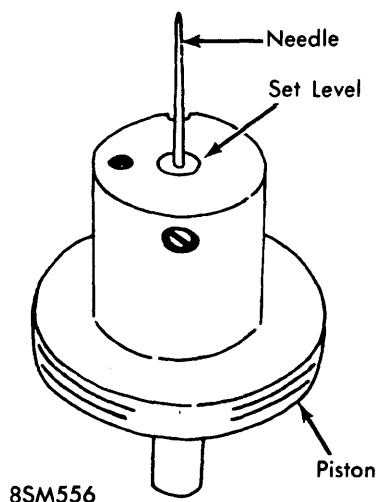

POSITIONING NEEDLE

**Cold Starting Device Adjustment** — Adjustment is correct, when clearance between throttle valve and throttle chamber is .0232-.0271 in. (.59-.69 mm), when choke lever is pulled all the way out. Adjust by bending connecting rod. Throttle opening is increased by increasing length of connecting rod.

### TROUBLE SHOOTING

**Carburetor flooding** — A) Float leaking or defective, repair or replace. B) Dirty needle valve seat, clean. C) Needle valve loose, tighten. D) Needle valve seat defective, replace. E) Excessive fuel pump pressure, adjust. F) Fuel pump drawing in air, repair.

**Excessive Fuel Consumption** — A) Carburetor flooding, see above. B) Faulty suction piston operation, repair or replace. C) Defective jet return, adjust. D) Worn jet needle, replace. E) Worn jet, replace. F) Improper idle adjustment, adjust. G) Jet needle not properly installed, adjust. H) Improper cold starting device adjustment, adjust.

**Lack of Power** — A) Throttle valves do not open fully, adjust. B) Faulty suction piston operation, repair or replace. C) Faulty

jet return, adjust. D) Clogged jet or fuel line, clean. E) Jet needle not properly installed, adjust. F) Clogged needle valve, clean. G) Defective fuel pump, adjust, repair or replace.

**Poor Idle** — A) Faulty suction piston operation, repair or replace. B) Faulty jet return, adjust. C) Worn jet needle, replace. D) Improper idling adjusting nut adjustment, adjust. E) Worn throttle valve shaft, replace. F) Air leakage due to defective gasket between manifold and carburetor, replace gasket. G) Improper cold starting device adjustment, adjust. H) Loose throttle lever interlock link, adjust or repair.

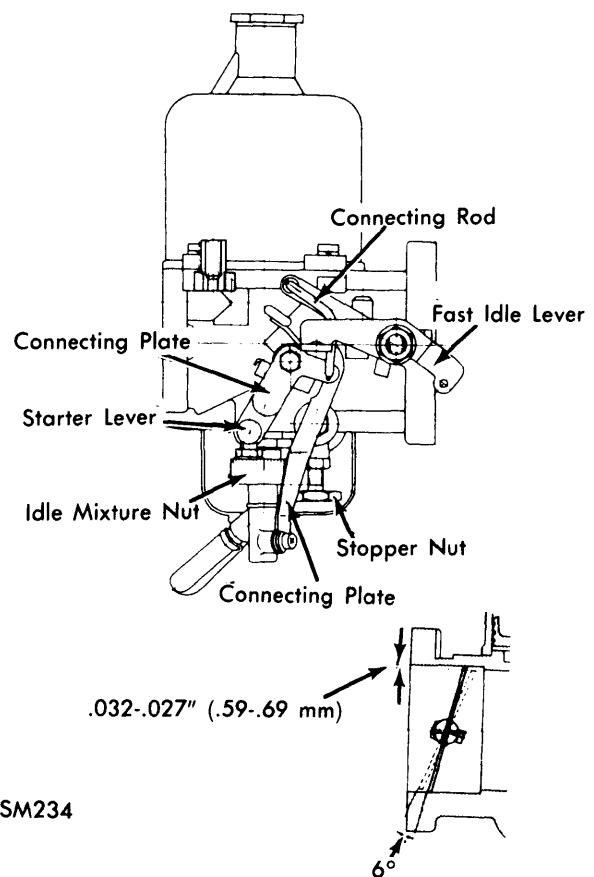

COLD START DEVICE ADJUSTMENT

**Poor Engine Operation** — A) Defective suction piston, repair or replace. B) Insufficient damper oil or improper oil used, replenish or replace. C) Improper idle adjustment, adjust. D) Jet needle not properly installed, adjust.

**Engine Does Not Start** — A) Carburetor flooding, see above. B) No fuel feed to engine, check fuel pump, fuel line and needle valve. C) Improper idle adjustment, adjust. D) Defective suction piston, repair or replace.

**Faulty Suction Piston Operating** — A) Sticking due to dirt or other foreign matter, clean. B) Sticking due to deformation of suction chamber or piston, repair or replace. C) Jet not properly centered, correct. D) Bent jet needle, replace. E) Bent plunger rod, correct.