

Hitachi Carburetors

HITACHI DCH 340 2-BARREL

Datsun 510 (1973)
 Datsun 610 (1973)
 Datsun 620 Pickup (1973)

DESCRIPTION

Carburetor is a 2-barrel downdraft type and is equipped with a piston type accelerator pump and an electrically actuated choke system. Carburetor consists of a low speed (primary) barrel and a high speed (secondary) barrel integrated into a single unit. The secondary throttle is actuated by a vacuum diaphragm unit. Linkage between primary and secondary throttles prevents secondary throttle from being opened by vacuum diaphragm whenever primary throttle opening is less than 50°. Carburetor is also equipped with an anti-dieseling solenoid and a boost controlled deceleration device, BCDD. The anti-dieseling solenoid cuts off fuel supply when ignition is shut off. The boost controlled deceleration device reduces HC emissions during deceleration by lowering manifold vacuum and causing complete combustion of fuel.

OPERATION

POWER SYSTEM

During low speed operation, fuel delivery is made by primary side. A booster power valve is operated by intake manifold vacuum. During light load operation this vacuum is high enough to keep power valve closed against spring pressure. During heavy load operation and acceleration, intake manifold vacuum drops and allows spring action to open valve and supply fuel to primary throttle bore.

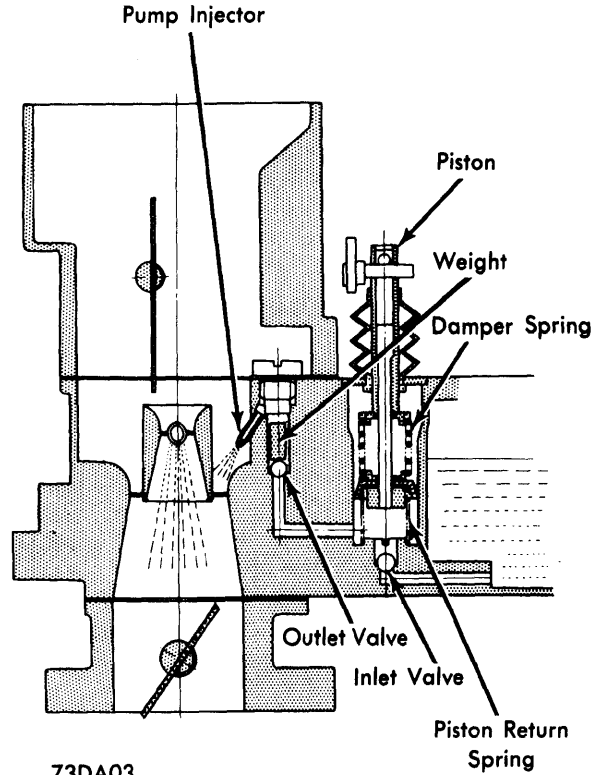

ACCELERATOR PUMP SYSTEM

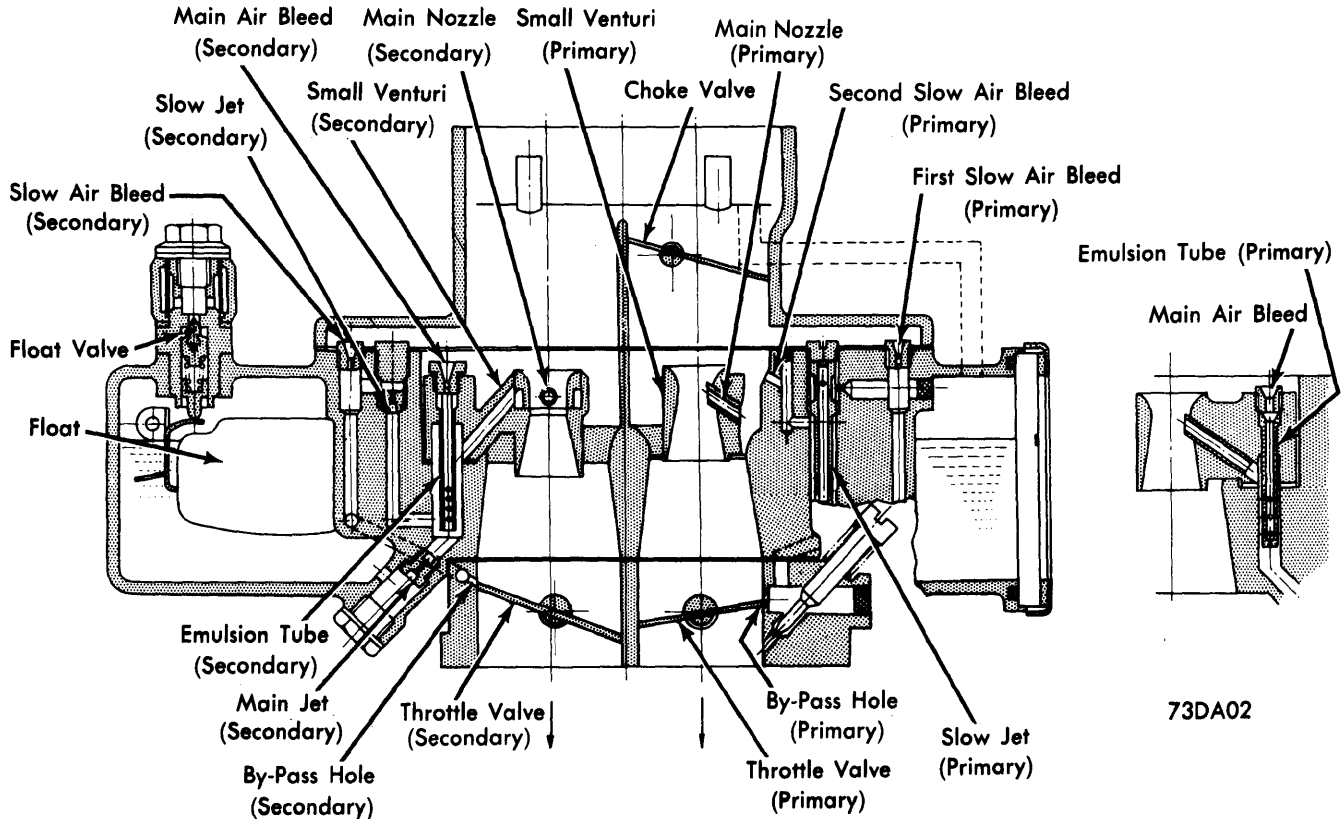

HITACHI DCH340 SECTIONAL VIEW

HITACHI DCH 340 2-BARREL (Cont.)

BOOST CONTROLLED DECELERATION DEVICE

The boost controlled deceleration device acts to reduce the amount of hydrocarbon emissions during deceleration. High manifold vacuum during deceleration prevents complete combustion resulting in high hydrocarbon emissions. When manifold vacuum exceeds a predetermined amount, a valve is opened in a separate mixture passage in carburetor allowing an additional richer mixture into manifold. This causes complete combustion of fuel lowering hydrocarbon emissions. System consists of a dual diaphragm vacuum control valve and an electrical vacuum control solenoid valve actuated by a signal from transmission.

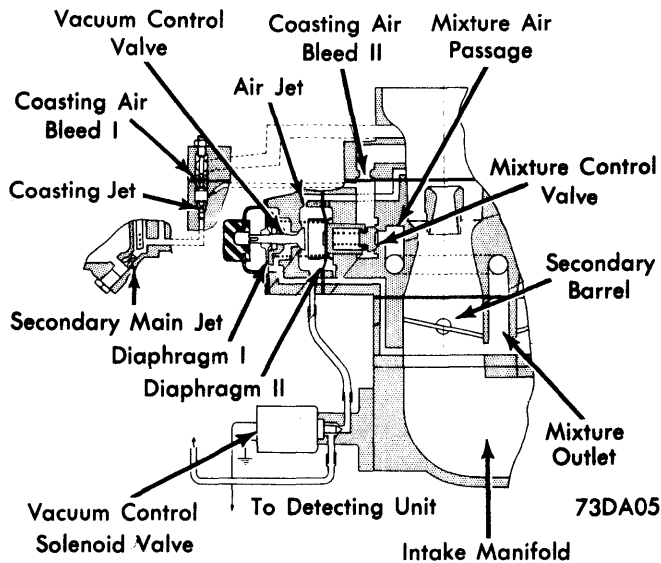

BOOST CONTROLLED DECELERATION DEVICE

ANTI-DIESELING SOLENOID

The anti-diesling solenoid is installed in the slow circuit of carburetor. When the ignition is off the solenoid is actuated, closing valve in slow circuit and cutting off fuel.

ELECTRIC AUTOMATIC CHOKE

As engine is started, an electric heater warms a bimetal spring in choke housing. Choke and throttle valves are controlled by bimetal spring in accordance with the temperature of engine.

DASHPOT

This device is installed on vehicles with automatic transmission only. The dashpot prevents engine from stalling if vehicle is stopped quickly. The dashpot is connected to primary throttle valve through a link mechanism. When vehicle is stopped suddenly, dashpot prevents throttle from closing completely.

ADJUSTMENT

IDLE-RPM & MIXTURE RATIO

NOTE — This procedure must be accomplished with a CO meter. Make sure meter is correctly calibrated and thoroughly warmed up before using meter.

1) With engine at normal operating temperature, manual transmission in neutral and automatic transmission in "N", adjust throttle adjusting screw so that engine is idling at 800 RPM.

2) Check timing and if necessary adjust timing to 5° BTDC. On manual transmission vehicles, adjust idle adjusting screw until CO meter reads $1.5 \pm 0.5\%$. Check idle RPM and if necessary repeat procedure so that engine is idling at 800 RPM and CO meter still reads $1.5 \pm 0.5\%$.

3) On automatic transmission vehicles, apply parking brake, block both front and rear wheels and place transmission in "D". Adjust carburetor so that CO meter reads $1.5 \pm 0.5\%$ at 650 RPM.

4) If idle limiter cap must be removed to properly reach correct CO level, cap must be installed in correct position. With proper level obtained, install cap so it can still allow idle screw $\frac{1}{8}$ turn in the CO rich direction (see illustration).

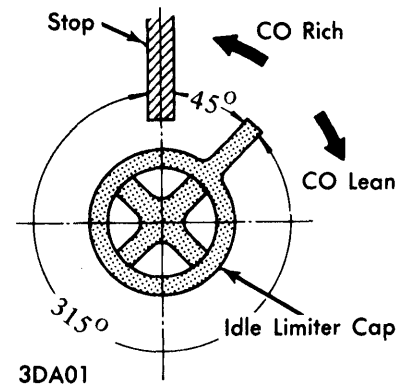

IDLE LIMITER CAP INSTALLATION POSITION

FUEL LEVEL ADJUSTMENT

If fuel level is even with level gauge line, fuel level is properly set. If fuel level is outside the line, adjust by bending float seat. The needle valve requires an effective stroke of .06". Adjust float stopper until needle valve obtains proper stroke.

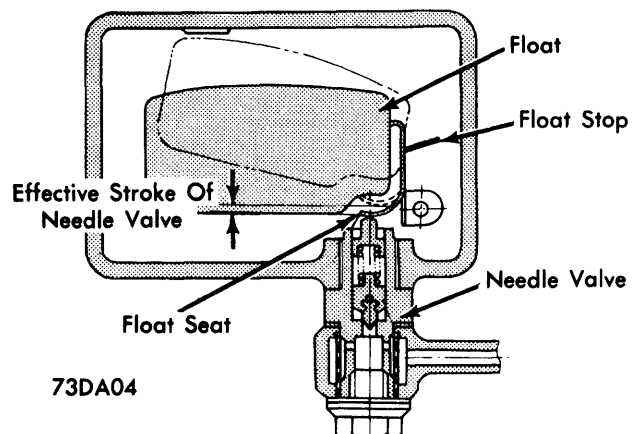

FLOAT LEVEL ADJUSTMENT

HITACHI DCH 340 2-BARREL (Cont.)

FAST IDLE ADJUSTMENT

When the choke valve is fully closed, the throttle valve automatically opens to the correct angle for starting engine. Adjust fast idle adjusting screw to obtain correct fast idle RPM specifications.

Fast Idle RPM

Application	Idle RPM
W/Auto. Trans.	2400 ± 100
W/Man. Trans.	2000 ± 100

VACUUM BREAK ADJUSTMENT

Vacuum diaphragm provides for proper air/fuel mixture for starting while choke is fully closed. To check or adjust, stretch a rubber band over choke piston lever and stationary part of carburetor. Grip vacuum brake rod with a pair of pliers. Adjust gap between choke valve and carburetor to .067" by bending rod.

CHOKE UNLOADER ADJUSTMENT

When engine is accelerated before warmed sufficiently, the unloader ensures that choke will open a certain amount to provide correct fuel/air mixture. To adjust unloader, proceed as follows:

- 1) Close choke valve completely and stretch a rubber band over choke piston and stationary part of carburetor to ensure that choke valve will stay closed.
- 2) Open throttle valve completely. Now bend unloader tongue until clearance between choke valve and carburetor body is .173".

BIMETAL COVER ADJUSTMENT

- 1) Before adjusting bimetal cover, bimetal resistance should be checked. With bimetal installed on car and at a temperature of 70°F, resistance should be 9.8 to 10.2 ohms.
- 2) Set cover so index mark is in center of marks on housing. If an overchoked condition exists, loosen screws and turn cover one mark clockwise.

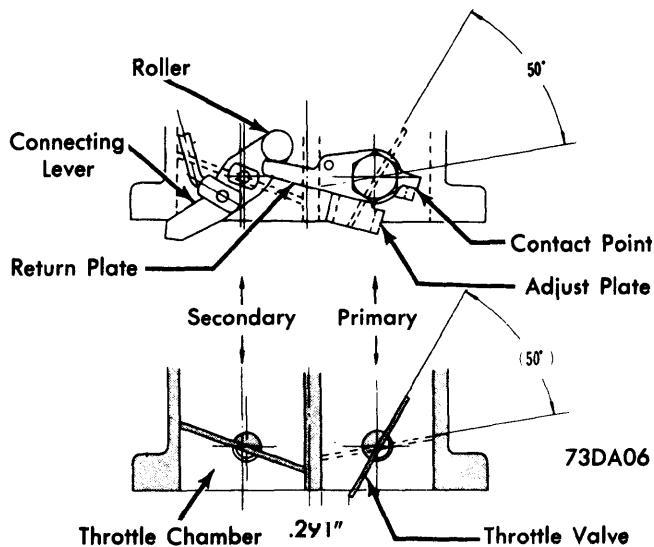

PRIMARY & SECONDARY THROTTLE LINKAGE

PRIMARY & SECONDARY THROTTLE VALVE OPENING

1) When primary throttle valve is opened to an angle of 50°, adjusting plate on primary throttle valve comes in contact with return plate. As primary throttle valve is opened further, locking plate is detached from secondary throttle valve and valve starts opening.

2) To ensure that primary and secondary throttle linkage is operating correctly, measure distance between primary throttle valve and throttle chamber as secondary throttle valve is just starting to open. Distance should be .291". Bend connecting link until correct distance is obtained.

DASHPOT ADJUSTMENT

1) For dashpot to correctly operate, the proper distance between throttle lever and dashpot stem must be obtained. Contact can be adjusted by dashpot set screw. If dashpot continues to function improperly, dashpot must be rotated to proper position.

2) To properly adjust dashpot by turning complete unit, idle speed and mixture must be properly set and engine must be at normal operating temperature. Actuate throttle by hand and read engine RPM when dashpot stem just contacts throttle lever.

3) Adjust position of dashpot by rotating either way until engine is idling at 1600 to 1800 RPM. Tighten dashpot lock nut. Engine should reduce from approximately 2000 RPM to 1000 RPM in three seconds.

OVERHAUL

DISASSEMBLY

NOTE — Do not remove either primary or secondary throttle plates.

Carburetor Assembly — 1) With carburetor removed from intake manifold, remove throttle return spring from primary side. Remove accelerator pump lever and rod.

2) Remove cam connecting rod. Remove three screws from choke cover and remove cover. Remove four screws and remove choke housing and throttle return spring from secondary side.

3) Remove four screws and separate float chamber from throttle chamber. Remove diaphragm assembly, with gasket. Remove fast idle cam, cam spring and counter lever.

4) Remove fuel inlet line nipple retaining screw, nipple and filter screen. Remove needle valve and stopper plate. Remove cylinder plate, pump cover, piston, piston return spring and inlet valve.

5) Remove injector spring and outlet valve. Remove small venturies, main air bleed and emulsion tubes from both primary and secondary sides. Remove slow jet, slow air bleed and primary and secondary main jets.

6) Remove level gauge cover, float chamber, level gauge, rubber seal, float shaft and float. Remove power valve. Remove return plate, sleeve, fast idle lever, spring hanger and throttle lever.

Anti-Diesling Solenoid — Anti-Diesling solenoid is secured in carburetor with a special sealer applied at factory. Using a suitable tool (ST19150000), remove solenoid from carburetor assembly. If tool is not available, carefully remove solenoid with a pair of pliers.

HITACHI DCH 340 2-BARREL (Cont.)

CLEANING & INSPECTION

1) Clean all carburetor components in a suitable cleaning solution. Blow off all components and air passages with compressed air.

NOTE — Do not attempt to clean any jets or air passages with drills or wire as damage to calibrated components might occur.

2) Inspect all components for wear or damage and replace as necessary. Check accelerator pump for wear or damage. Pour fuel into float chamber and check operation of accelerator pump.

ASSEMBLY

To assembly carburetor, reverse disassembly procedure. Care must be taken not to bend or distort any linkage components. Replace any gaskets as necessary.

Anti-Dieseling Solenoid — Before installing solenoid, thoroughly clean threads. Install solenoid in carburetor two or three turns. Coat all exposed threads with Loctite or equivalent

sealer. Tighten solenoid to 35 to 55 ft. lbs. with a suitable tool (ST19150000). After installing solenoid, carburetor should set for approximately twelve hours. With carburetor installed, carefully inspect sealing of solenoid for possible leaks.

CARBURETOR SPECIFICATIONS

Application	Specification
Main Jet	
Primary	#97.5
Secondary	#170
Main Air Bleed	
Primary	#65
Secondary	#60
Slow Jet	
Primary	#48
Secondary	#90
Slow Air Bleed	
Primary	#145
Secondary	#100
Power Jet	#53