

## MOTORCRAFT 4300 4-BARREL

Pantera (1973)

### CARBURETOR IDENTIFICATION

Carburetor model designation and suffix stamped on tag attached to carburetor by one air horn screw. First letter on second line of tag indicates design changes which may affect parts replacement. Ford carburetors may have Ford or Motorcraft stamped on identification tag.

### DESCRIPTION

Carburetor consists of three main parts; air horn, main body, and throttle body. Fuel bowl is vented by an internal balance vent. On some models, a hot idle compensator is used. Main (primary) fuel system has booster type venturis cast into air horn and main venturis are cast into main body. Secondary throttle plates are mechanically operated from primary linkage. Secondary air valves are located below secondary venturis. Secondary fuel supply is controlled by metering rods which are attached to air valve plates. A single fuel bowl supplies both primary and secondary fuel systems. Accelerator pump is piston type. Automatic choke is bi-metal thermostatic spring with electric assist.

### ADJUSTMENT

#### ACCELERATOR PUMP STROKE

The accelerator pump stroke has been set to help maintain the exhaust emission level of the engine within specified limits and normally the accelerator pump stroke should not be changed

from the specified setting. However, three holes are provided in pump link or operating arm and bracket, and pump may be adjusted if necessary.

**Pump Stem Height** — Before adjusting accelerator pump stroke, measure height of pump piston stem (as shown in illustration). Bend pump control rod to adjust to  $.380" \pm .020"$ .

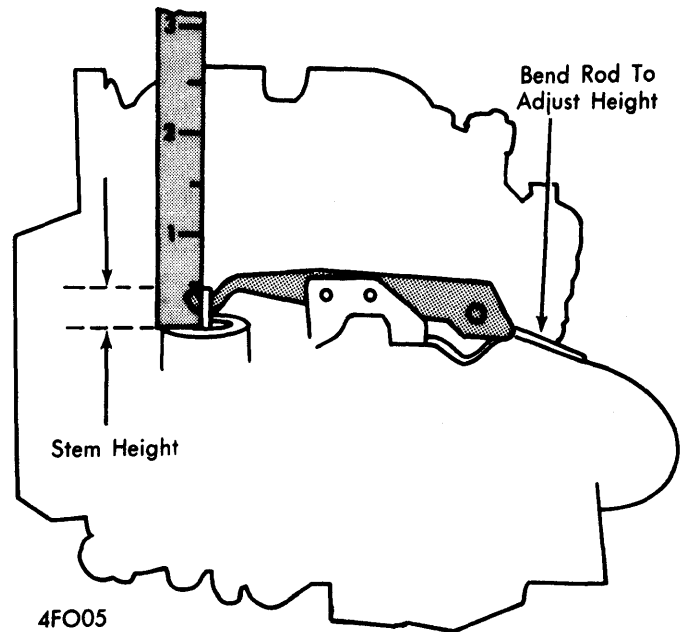

ACCELERATOR PUMP HEIGHT

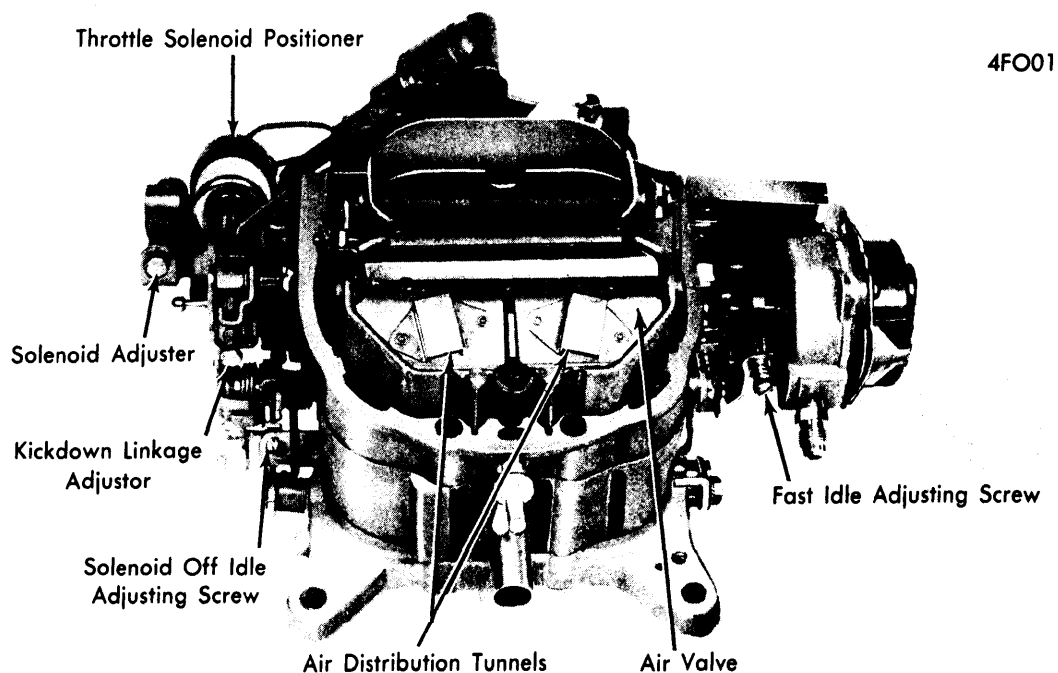

### MOTORCRAFT MODEL 4300-D

## MOTORCRAFT 4300 4-BARREL (Cont.)

**Pump Adjustment** — Disconnect pump rod from pump link before removing pump pivot pin. Line up holes in pump link and pivot hole in main body casting before attempting to reinstall pivot pin in correct hole. Make certain that split end of pivot pin is spread, so it will be retained in place.

### CHOKE VALVE PULLDOWN

**Preparation For Adjustment** — Remove thermostatic cover retainer, cover and thermostatic spring. Bend a .036" wire gauge at 90° angle, approximately 1/8" from end. Block throttle half open, so fast idle screw contacts fast idle cam. Insert bent end of gauge between piston slot and upper end of right hand slot in choke housing. Maintain slight pressure on choke lever, to hold piston in place. Use gauge or drill of correct size (see specifications) to check clearance between lower edge of choke valve and air horn wall. If necessary to adjust, proceed as follows:

**Adjustment** — 1) Loosen hex head screw (left hand thread) on choke valve shaft and pry link away from tapered choke shaft.

2) With a drill gauge .010" under the specified clearance, between lower edge of choke plate and air horn wall, hold choke valve against gauge with slight pressure on choke lever.

3) With choke piston firmly against .036" wire gauge and choke valve against drill gauge, tighten hex head screw on choke valve shaft. **NOTE** — Adjustment is made with choke

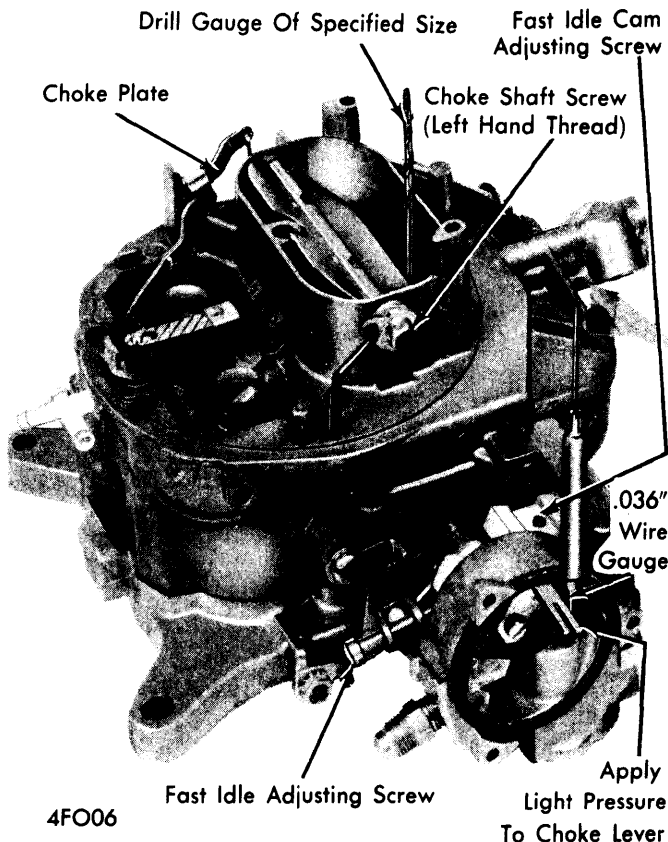

### CHOKE PLATE PULL-DOWN & FAST IDLE CAM ADJUSTMENT

valve drill gauge .010" under specified clearance to allow for tolerances in linkage.

4) Recheck choke valve pull-down using choke valve drill gauge of size specified in adjustment specifications (.010" larger than checking gauge).

### FAST IDLE CAM CLEARANCE

Install choke cover and thermostatic coil loosely (make certain coil end engages choke lever slot). Rotate cover to 90° rich position, then place fast idle speed screw on kickdown (center) step of the fast idle cam, against shoulder of the high step of cam, and hold it in this position. Using a drill or gauge of correct size (see specifications), check clearance between lower edge of choke valve and air horn wall. If fast idle cam clearance not correct, adjust by turning fast idle cam adjusting screw in or out as necessary. **NOTE** — This is not the fast idle speed adjusting screw, but the cam adjusting screw.

### FLOAT LEVEL

**NOTE** — It is recommended that a Float Gauge tool be made up for this purpose. Dimensions of tool are shown in illustration.

**Float Level (Primary Fuel Valve)** — Adjust nuts on float gauge tool for correct float level setting. With air horn and float assembly removed and inverted, install float gauge over floats with locating bolts installed in outboard holes of air horn. Both floats should just touch underside of float gauge bar. Align floats by slightly twisting float arms, adjust float height by bending primary needle tab (inner tab on float arm) up or down as required. **NOTE** — Raise floats so that tab clears primary needle.

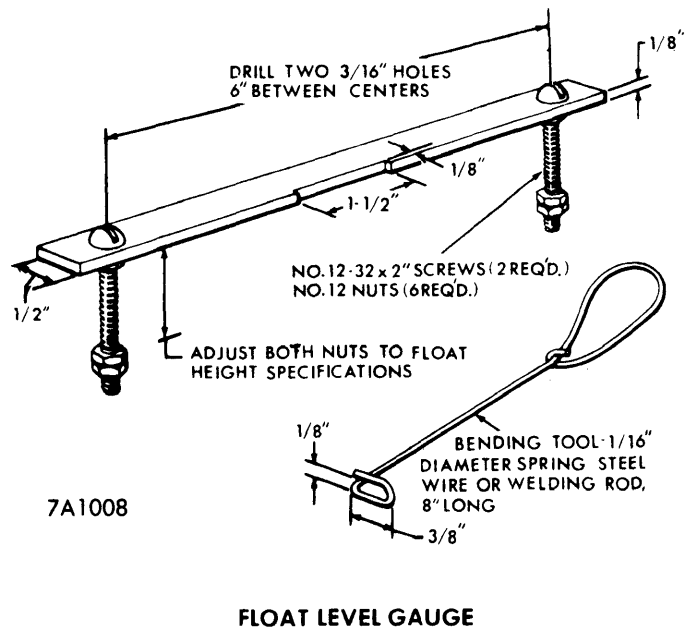

**Auxiliary Fuel Valve** — After adjusting primary fuel valve, check clearance between auxiliary fuel valve pin and tab on rear of float arm. If clearance not correct, adjust by bending this tab up or down as required.

## MOTORCRAFT 4300 4-BARREL (Cont.)

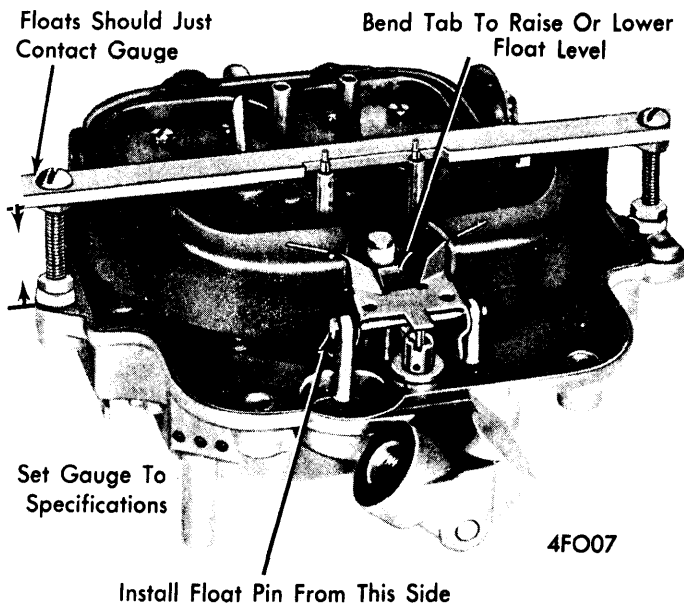

**FLOAT LEVEL ADJUSTMENT**

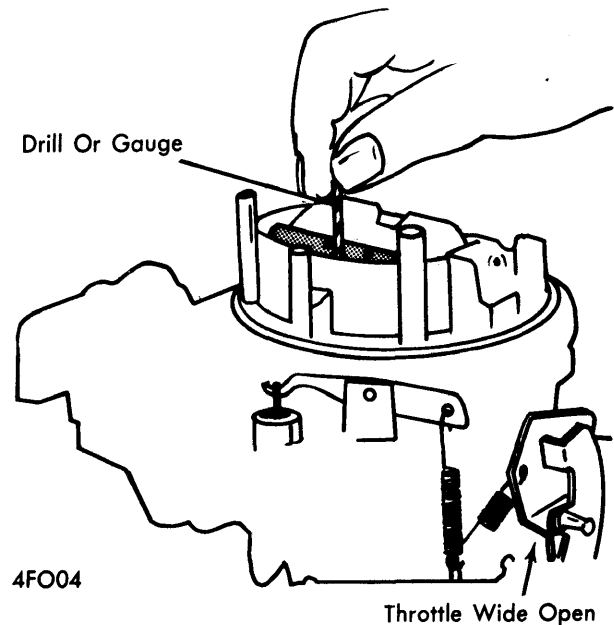

**CHOKE UNLOADER ADJUSTMENT**

### AUTOMATIC CHOKE

Loosen choke cover retainer screws, rotate cover to align index mark on cover flange with correct graduation of scale on housing. Tighten retainer screws after adjustment completed.

### DASHPOT SETTING (IF EQUIPPED)

With throttle valves closed at curb idle position, depress dashpot plunger fully and check clearance between dashpot plunger stem and throttle lever. If clearance not in accordance with specifications in following table, adjust by loosening locknut and turning dashpot in or out of mounting bracket as required.

### FAST IDLE SPEED

Rotate fast idle cam so that fast idle screw contacts kick-down (middle) step of fast idle cam. With engine at normal operating temperature, adjust fast idle screw by turning screw in or out for correct fast idle speed.

**NOTE** — On vehicles equipped with spark delay device, set fast idle with ambient temperature above 55°F with a vacuum line connected directly from carburetor spark port to advance side of distributor and vacuum line to EGR valve disconnected and plugged.

### HOT IDLE COMPENSATOR

**NOTE** — On those cars equipped with hot idle compensator, make sure bi-metal strip is cool and that compensator plug is seated before attempting to make carburetor idle adjustments.

### CHOKE UNLOADER

Hold throttle valves in wide open position, rotate choke valve toward closed position until pawl on fast idle lever contacts fast idle cam. Use gauge or drill of specified size to check clearance between lower edge of choke valve and air horn wall. If this clearance not correct, adjust by bending pawl on fast idle speed lever forward or backward as required.

### IDLE SPEED (THROTTLE STOP) SOLENOID

**NOTE** — In order to comply with emission standards, specifications shown on engine compartment emission control tune-up decal must be used in all instances. Decal information should be considered the most valid information available. If performing only adjustment procedures, do not remove idle mixture limiter caps.

**Preparations For Adjustment** — Block wheels and apply parking brake. Start and warm engine to normal operating temperature. Set timing and idle. Turn mixture screws to full rich stops (counterclockwise). Remove air cleaner, disconnect and plug evaporator canister-to-air cleaner hose.

**Adjustment** — With solenoid energized (if equipped), turn solenoid adjusting screw to obtain specified idle RPM. Place automatic transmission in "N" and disconnect solenoid wire. Adjust carburetor idle speed screw to obtain 500-550 RPM. Reconnect solenoid wire and allow plunger to extend. Stop engine and replace air cleaner and connect all vacuum hoses. Restart engine and readjust solenoid (if equipped) and mixture screws to obtain smoothest possible idle at specified idle RPM.

### IDLE SPEED & MIXTURE (EXHAUST GAS ANALYZER PROCEDURE)

**NOTE** — Do not allow engine to idle more than two minutes at one time. If adjustments take longer, raise engine speed to 2000 RPM to stabilize engine temperature, then continue with adjustments.

Preparations for adjustment must be completed. See *Idle Speed (Throttle Stop) Solenoid*. Connect exhaust gas analyzer and place automatic transmission in "D" or manual transmission in Neutral. If idle CO level is not within specifications, recheck meter calibration, then recheck idle CO level.

## MOTORCRAFT 4300 4-BARREL (Cont.)

2) If CO level is still not within specifications, remove air cleaner and idle mixture limiter caps. Adjust mixture screws to obtain specified CO level and immediately readjust idle speed to specifications. Install air cleaner and recheck CO level.

3) Repeat adjustment procedure, if necessary, to obtain correct CO level at specified idle RPM. Install new (blue) limiter caps.

### OVERHAUL

**NOTE** — Carburetor consists of three main castings: air horn, main body, and throttle body, which are separated and then disassembled separately as follows:

#### DISASSEMBLY

**Air Horn** — 1) Disconnect choke control rod from automatic choke lever and accelerating pump rod from throttle lever. Remove all air horn-to-main body retaining screws and carefully lift air horn off main body.

2) Remove float pivot pin and lift out float assembly, use correct size screwdriver (or jet removal tool) to remove main and auxiliary fuel inlet seat assemblies and gaskets.

3) Disconnect secondary air valve lever rods from dampener piston assembly and air valve, remove dampener piston and rod assembly.

4) If necessary to remove secondary air valves or shaft, scribe index mark on air valve housing and body casting, remove valve retaining screws and valves, then slide shaft out of air horn.

5) If necessary to remove choke valve or shaft, remove staking marks on choke valve retaining screws or file off flared portion of screws, remove retaining screws and valve, then slide shaft out of air horn.

6) Take out attaching screws and remove hot idle compensator valve assembly. Do not remove power valve vacuum valve assembly unless it is to be replaced. Remove staked areas and remove valve assembly carefully to avoid damage to air horn casting.

**Main Body** — 1) Invert main body assembly and catch accelerating pump discharge needle which will fall out.

2) Use  $\frac{3}{8}$ " deep socket to remove power valve and jet tool to remove main metering jets from within fuel bowl.

3) Remove check ball retainer from bottom of accelerating pump cylinder with long nosed pliers, then invert main body and catch pump inlet ball check which will drop out.

4) Remove throttle body-to-main retaining screws from bottom of throttle body and separate the two castings.

**Throttle Body** — 1) **CAUTION** — Do not remove idle mixture limiter caps, screws, and springs. Remove automatic choke housing cover screws, retainer, cover, gasket and thermostatic spring assembly. Remove choke piston lever retaining screw, then remove piston assembly.

2) Remove secondary throttle-to-primary throttle lever connecting link. If necessary to remove primary or secondary throttle valves or shafts, remove staking marks on throttle valve attaching screws, remove screws and valves.

3) After valves removed, remove nut from secondary throttle shaft, slide shaft and return spring out of throttle body.

4) After valves removed, remove nut from primary throttle shaft and remove fast idle lever and adjusting screw, then slide primary throttle shaft and lever assembly out of throttle body. Remove throttle lever assembly retainer, slide lever and springs off shaft.

5) If necessary to remove fast idle cam or bushings, press bushing out of choke housing and bushing column. **CAUTION** — Housing and column must be properly supported during bushing removal and installation to prevent bending or breaking of the column.

#### CLEANING & INSPECTION

Clean all castings and metal parts in cleaning solution (plastic fast idle cam and air valve spring cover can be cleaned in the solution but floats and gaskets should not be immersed in the solution). Rinse parts in hot water, soak in gasoline, and dry with air. Blow out all passages, jets, and tubes with air. Inspect all parts for wear, distortion or damage. Make certain power valve piston and rod move freely. **CAUTION** — Do not remove calibrating shims from power valve piston rod for cleaning and use care not to distort rod.

#### REASSEMBLY

Use all new gaskets. Reassemble carburetor by reversing disassembly procedure with particular attention to the following points:

**Primary Throttle Valve Installation** — Install return spring (coiled clockwise) on primary throttle shaft and insert shaft in throttle body. Position throttle valves on shaft with ground flat edge of valves facing upwards and toward idle mixture needles, install valve screws just snug. Rotate shaft to closed position, tap valves lightly to properly seat them in throttle bore (when viewed against a light, little or no light should be visible around valves), then tighten valve screws securely.

**Fast Idle Cam & Bushing Installation** — Start bushing through choke housing, position fast idle cam between housing and bushing column and slide bushing through fast idle cam, then support bushing column and press bushing into position in column. Clean bushing with  $\frac{1}{4}$ " reamer before installing choke shaft and lever.

**Choke Valve Installation** — Insert choke shaft in air horn with lever end on automatic choke side, install choke valve and tighten attaching screws just snug, then close valve and tap lightly to position it in air horn, tighten attaching screws and stake screws to prevent loosening. Install a new seal on choke control rod, press seal into air horn and attach control rod to choke shaft lever. **CAUTION** — Seal must grip ledge in air horn at all four points to prevent unfiltered air entering carburetor.

**Air Valve Installation** — Slide air valve shaft in air horn with slotted end of shaft in air valve spring chamber. Position plain air valve in air horn opening adjacent to spring chamber and tighten attaching screws just snug, install air valve in other air horn opening with control rod eye facing upward, install attaching screws just snug. Close air valves and tap valves lightly to position them in air horn, then tighten attaching screws and stake the screws to prevent loosening.

# Ford Carburetors

## MOTORCRAFT 4300 4-BARREL (Cont.)

