

AISAN 2-BARREL (TOYOTA 3RB & 3RC ENGINES)

Toyota Corona & Crown (4-Cyl.)

DESCRIPTION

The carburetor on the Crown and Corona is a two barrel downdraft type with an automatic choke. Heat for operation is supplied from the exhaust manifold. Carburetor is also equipped with a thermostatic valve to eliminate various heat problems resulting from expanding fuel, such as stalling, poor idling, and hard starting. Valve starts to open at 104°F and allows fresh air to flow directly into intake manifold.

ADJUSTMENT

NOTE - Carburetor adjust kit 09240-44010 for Crown and 09240-44010 and 09240-60030 for Corona, or equivalent is required to perform the following adjustments.

Float Level Adjustment

Turn carburetor cover top side down. Clearance between top of float and cover gasket surface should be .366" (9.3 mm). Adjust level by bending middle float tab.

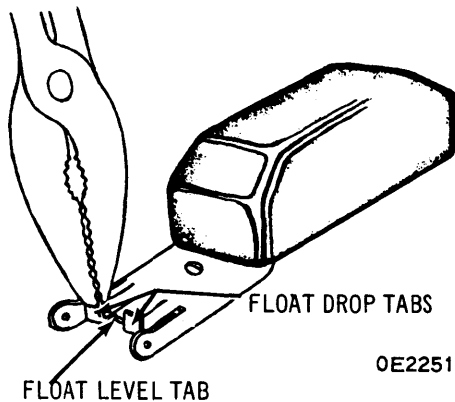

FLOAT TAB ADJUSTMENT

Float Drop Adjustment

Turn carburetor cover top side up. Clearance between top of float and gasket surface should be .867" (22 mm). Adjust level by bending two outside float tabs.

Fast Idle Adjustment

Close choke valve fully. Clearance between lower edge of throttle valve and throttle bore should be .040" (1 mm). Adjust fast idle screw to obtain proper clearance.

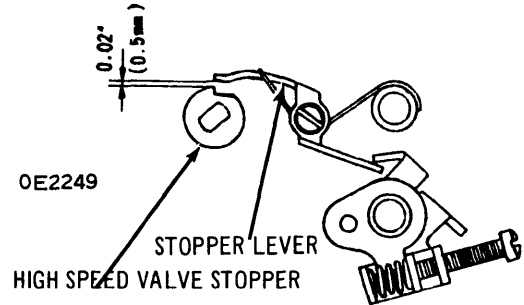

STOPPER LEVER ADJUSTMENT

Secondary Air Valve Stop Lever Adjustment

Check clearance between high speed valve stopper and stopper lever (see illustration). When secondary throttle valve just starts to open clearance should be .020" (.5 mm). To adjust clearance bend lip of stopper lever.

Secondary Throttle Valve Adjustment

Turn flange top side down. Adjust initial opening angle of secondary throttle valve by bending throttle shaft link so that secondary valve starts to open when primary throttle valve is opened to 60°.

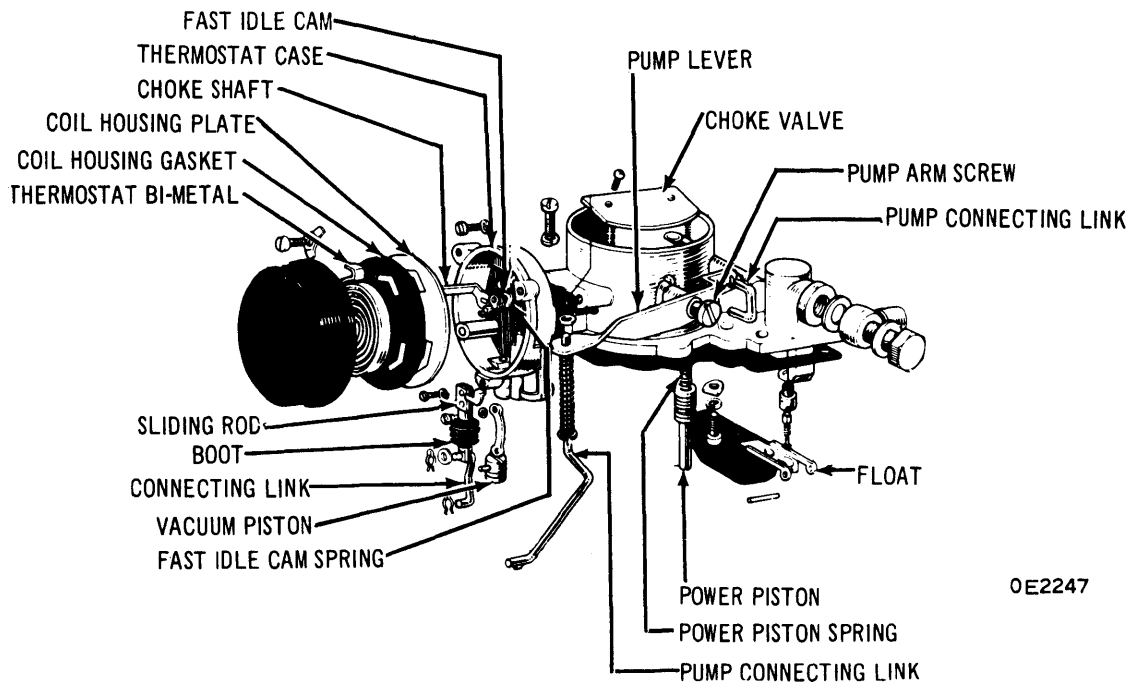

CARBURETOR COMPONENTS

Aisan Carburetors

AISAN 2-BARREL (TOYOTA 3RB & 3RC ENGINES) (Cont.)

Secondary Throttle Valve Initial Opening Angle

Turn flange top side down. Hold primary throttle valve at 30° before full opened position using angle gauge. Check

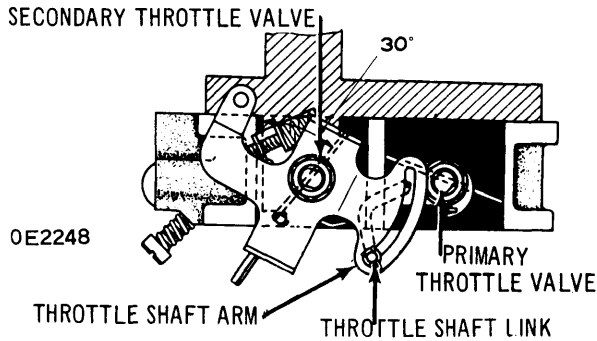

OE2248

ADJUSTING INITIAL OPENING ANGLE

throttle shaft link, it must touch extreme end of groove in throttle shaft arm. Adjust if necessary by bending link (see illustration).

Automatic Choke Adjustment

To adjust air/fuel mixture turn coil housing counterclockwise to richen mixture, and clockwise to lean mixture.

Idle Mixture Adjustment (Bench)

Proper off car pre-adjustment of idle mixture is three turns out from a fully closed position.

Idle Speed & Mixture

Alternately turn idle speed and mixture screws to obtain highest vacuum reading (18-21"). Idle speed should be 550 RPM (Auto Trans in "D").

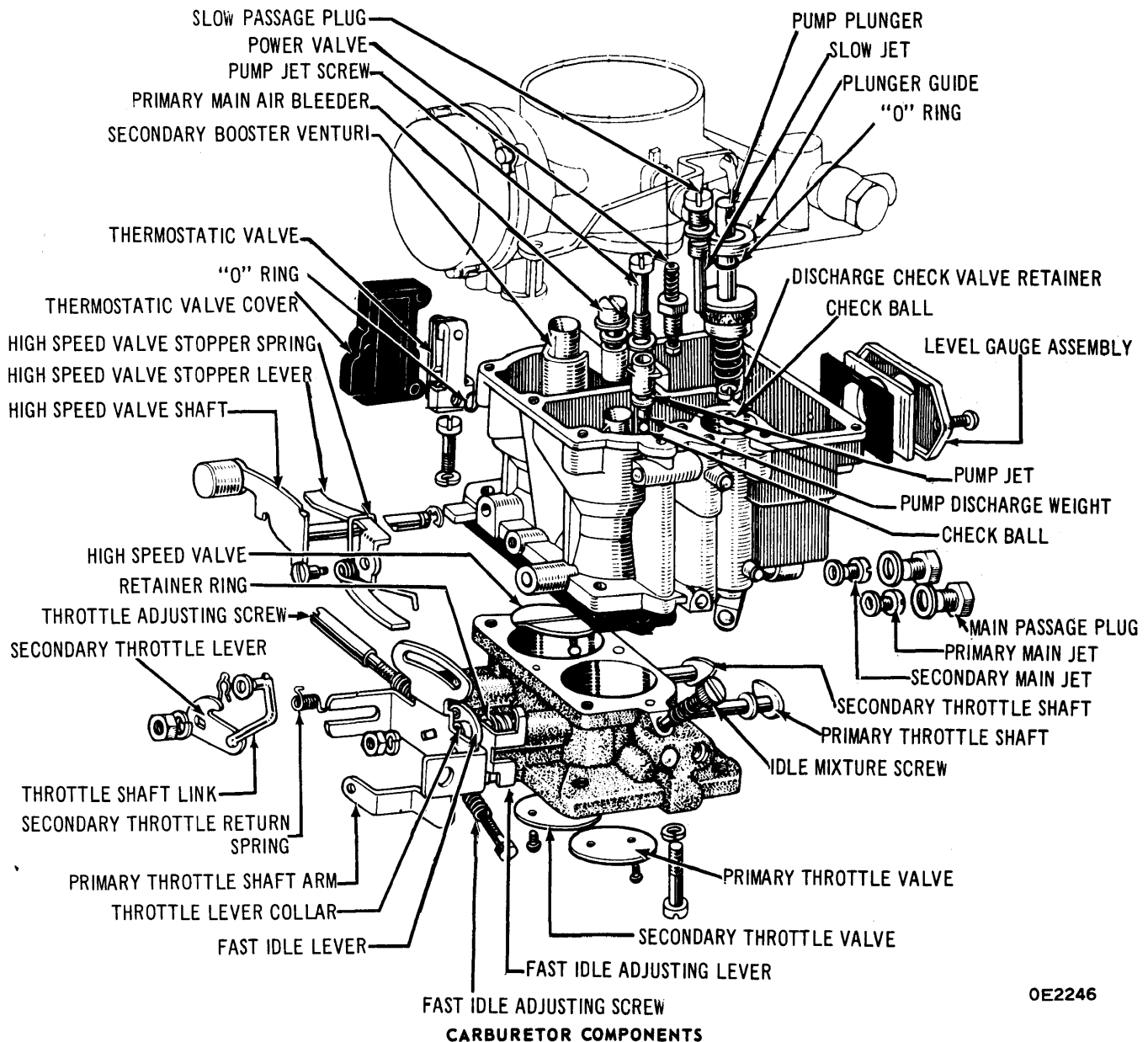

OE2246

FAST IDLE ADJUSTING SCREW

CARBURETOR COMPONENTS

AISAN 2-BARREL (TOYOTA 3RB & 3RC ENGINES) (Cont.)

Unloader Adjustment

Hold throttle valve at fully opened position. Install 50° angle gauge on choke valve. Adjust opening angle of choke valve so that it will open at 20° from the closed position which is 50°, partial open angle will be 70°. Adjust by bending fast idle cam follower (see illustration) or choke shaft lip.

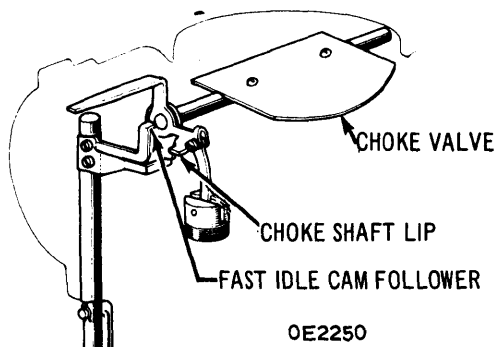

UNLOADER ADJUSTMENT

OVERHAUL

Disassembly

- 1) Remove choke connecting link and accelerator pump connecting link. Remove accelerator pump lever along with short connecting link. Remove six securing screws and lift carburetor cover off, being careful to avoid damaging float assembly. *NOTE - Short screw is located above thermostatic valve assembly and must be installed in same hole.*
- 2) To disassemble main body, pull out pump plunger and damping spring. Remove accelerator pump jet screw and pump jet. Invert carburetor and remove pump discharge weight and steel check ball. Remove primary and secondary main air bleeders. Remove primary and secondary booster venturis. Remove slow passage plug and slow jet.
- 3) Remove power valve. Remove thermostatic valve cover, and remove valve and "O" ring. Do not attempt to disassemble valve. Remove three flange retaining screws and

separate main body from cast flange. Remove primary and secondary main passage plugs and remove primary and secondary main jets.

4) Remove discharge check valve retainer and check ball. Remove stopper lever securing screw and high speed stopper lever and spring. Remove level gauge clamp, glass, and gasket.

5) Remove high speed valve. (It may be necessary to drill out staked portion of shaft screws with a .12" drill.) Remove retaining ring and slide shaft from housing.

6) To disassemble flange, remove idle adjusting screw and idle speed screw. Remove throttle shaft retaining ring and throttle lever retaining nut, and then remove primary throttle shaft arm, fast idle adjusting lever and throttle lever collar.

7) Remove fast idle adjusting bolt and disassemble fast idle lever and spring. Remove retainer ring, primary throttle valve and slide shaft from housing. Remove secondary throttle lever retaining nut, valve, and slide shaft from flange. Secondary throttle valve is thicker, and retaining screws are longer than primaries.

8) To disassemble carburetor cover, remove float pin and float. Remove needle valve assembly and seat. Remove power piston stopper, power piston, and spring. Remove filter trap and strainer.

9) To disassemble automatic choke, remove three retaining screws, remove coil housing, gasket, and housing plate. Be careful not to deform the bi-metal spring. Remove fast idle cam follower and sliding rod. Remove vacuum piston connecting screw, remove two choke valve retaining screws, remove valve, and slide shaft from housing.

10) Remove fast idle cam with spring from choke shaft. Remove vacuum piston with piston connector. Remove thermostatic case retaining screws, remove case and gasket from carburetor cover. Embossed mark on interior of coil housing indicates installing direction not position.

Reassembly

Reassembly is in reverse order of disassembly. Be sure to make all adjustments called for in adjustment section, and reassemble with all new gaskets. When installing throttle shafts be sure end play does not exceed .008" (.2 mm). Shims for correction come in .007", .012", .024", .039".