

## AISAN 2-BARREL - TOYOTA 4M ENGINES

Toyota Corona Mk II (1973)  
Toyota Crown (1972-73)

### DESCRIPTION

Carburetor is a two barrel design with primary and secondary venturis. Primary system is equipped with low speed circuit, high speed circuit, power circuit, acceleration circuit and automatic choke.

Secondary system consist of low and high speed circuits. Secondary throttle valve is operated by a vacuum diaphragm with vacuum ports in primary and secondary venturis. Low speed circuit supplies an air/fuel mixture when kick-up arm opens secondary throttle valve 2-4° from fully closed position.

**Thermostatic Valve (If Equipped)** - Prevents engine stalling, rough idle or hard starting caused by high engine temperatures. As the valve opens, it allows outside air to flow directly into the intake manifold, leaning out the rich air-fuel mixture. Valve starts to open when engine compartment temperature reaches 140°F (60°C) and fully opens at 167°F (75°C).

**Throttle Positioner** - Opens throttle valve slightly more than at idling when vehicle is being decelerated to maintain proper fuel combustion during deceleration.

### ADJUSTMENT

*NOTE* - It is recommended that a Toyota carburetor adjustment kit No. SST 09240-00010 be obtained to aid in following adjustments.

#### IDLE SPEED & MIXTURE

**1972** - Adjustment is made with air cleaner installed and engine at normal operating temperature. Connect a vacuum gauge and tachometer and proceed as follows: Adjust idle speed screw to obtain specified idle RPM. Adjust idle mixture screw to obtain highest and smoothest vacuum reading. Alternately adjust between idle speed screw and idle mixture screw until highest vacuum at specified idle RPM is obtained.

**1973** - With engine at normal operating temperature, air cleaner installed and vacuum gauge and tachometer connected, adjust throttle adjusting screw and mixture adjusting screw to obtain maximum vacuum at 700 RPM (Man. Trans. in N) or 650 RPM (Auto. Trans. in D). Race engine momentarily and check that idle returns to specified RPM. Now, using CO tester, check that CO value is between 1% and 3%. If CO value is too high, tighten mixture adjusting screw to obtain specified value. If specified CO cannot be achieved at specified idle speed  $\pm 50$  RPM, repeat idle adjustment and if necessary, check all other engine adjustments (valve clearance, ignition timing, etc.).

#### THROTTLE POSITIONER

*NOTE* - Throttle positioner diaphragm, spring and vacuum hose must be in good condition for proper operation. Check links and levers for freedom of movement.

Warm engine and adjust idle RPM to specification. Pull out thermo-sensor connector and disconnect vacuum hose from positioner diaphragm. Positioner linkage should now be set to hold throttle valve open. Set positioner adjusting screw to obtain 1300 RPM (Man. Trans.) and 1200 RPM (Auto. Trans.). Reconnect vacuum hose and thermo-sensor connector.

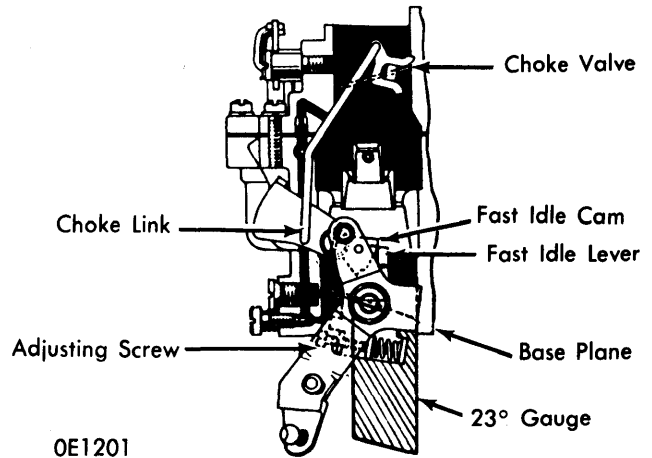

#### PRIMARY THROTTLE VALVE FAST IDLE ADJUSTMENT

##### FAST IDLE (BENCH)

- 1) With choke valve fully closed, fast idle lever must be at top of fast idle cam. Adjust by bending choke connecting link existing bend.
- 2) With choke valve closed, adjust fast idle speed adjusting screw so primary throttle valve is approximately 23° from base plane.

##### UNLOADER

Hold primary throttle valve wide open, choke valve should be opened approximately 35° from base plane. Adjust by bending fast idle lever.

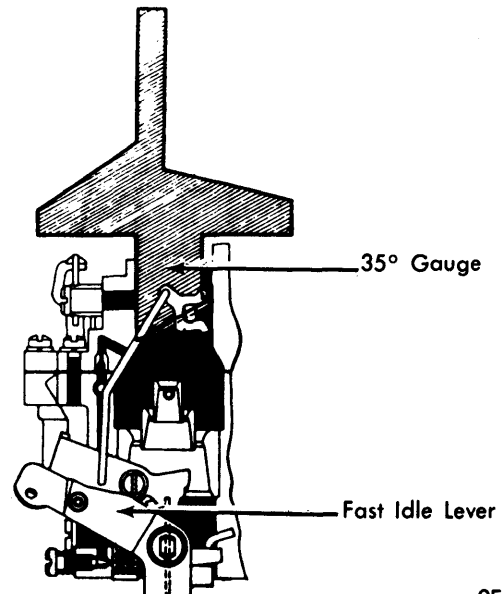

#### CHOKE UNLOADER ADJUSTMENT

##### AUTOMATIC CHOKE

Verify that choke valve will close from wide open when coil housing is turned clockwise. Choke plate should close at 77°F (25°C). One graduation on choke cover will vary choke sensing temperature 9°F (5°C). Basic setting for choke is with cover indexed to center mark on housing.

# Aisan Carburetors

## AISAN 2-BARREL - TOYOTA 4M ENGINES (Cont.)

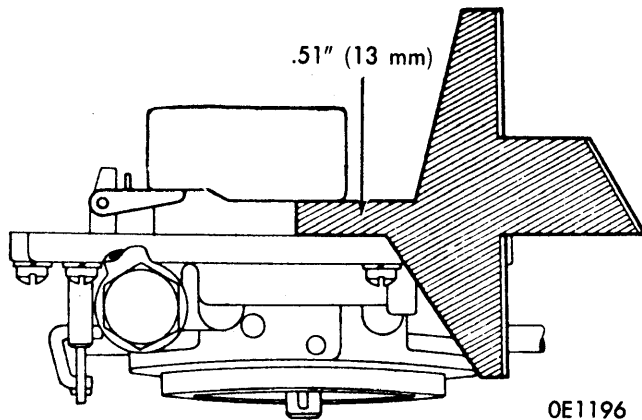

**FLOAT LEVEL (RAISED)**

**FLOAT LEVEL**

**Raised Position** - Invert air horn allowing float tang to rest on needle valve. Distance between end of float and air horn body should be .51" (13 mm).

**FLOAT DROP**

Turn carburetor cover top side down, raise float by hand. Clearance between needle valve push pin and float tab should be .035-.040" (.9-1.1 mm).

**FUEL LEVEL (ENGINE OPERATING)**

If fuel level is within level lines on carburetor sight glass with engine operating; fuel level is satisfactory.

**SECONDARY THROTTLE VALVE PRIMARY TOUCH**

Open primary throttle valve 55° measured from base plane, secondary throttle valve should start to open. At this point, primary kick arm and primary kick-up lever should contact. To adjust, bend kick-up lever (see illustration).

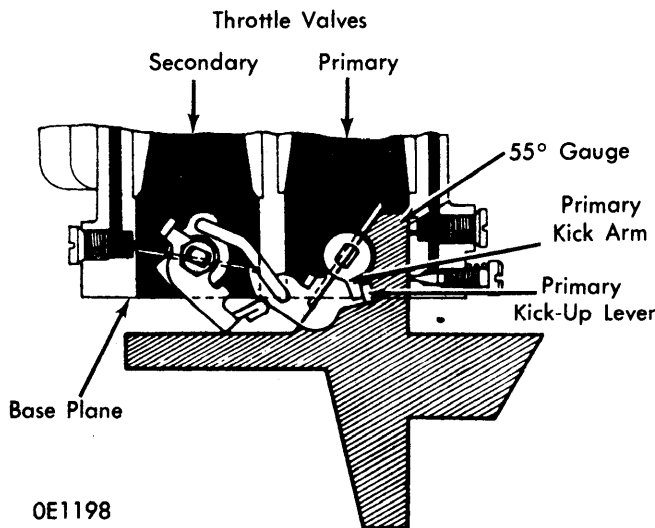

OE1198

**SECONDARY THROTTLE VALVE PRIMARY TOUCH**

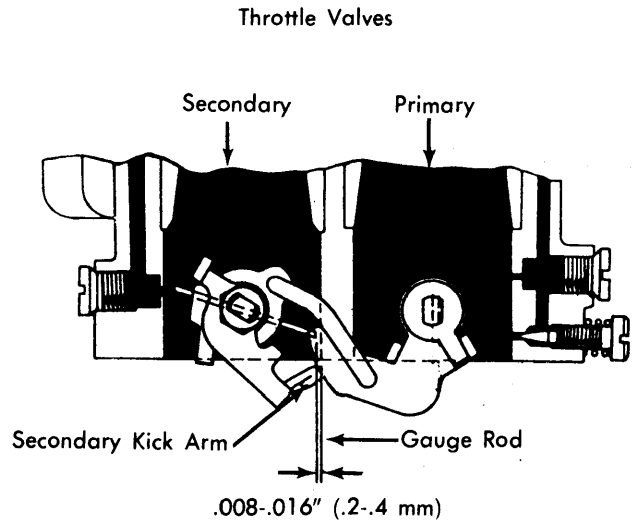

OE1199

**SECONDARY THROTTLE VALVE KICK-UP**

**SECONDARY THROTTLE VALVE KICK-UP**

Open primary throttle valve more than 62° measured from base plane, secondary throttle valve-to-body clearance should be .008-.016" (.2-.4 mm). To adjust, bend secondary kick arm (see illustration).

**FULL SECONDARY THROTTLE OPENING**

With primary throttle valve wide open, secondary throttle valve should be open 77° from base plane. To adjust, bend tang on secondary throttle shaft (see illustration).

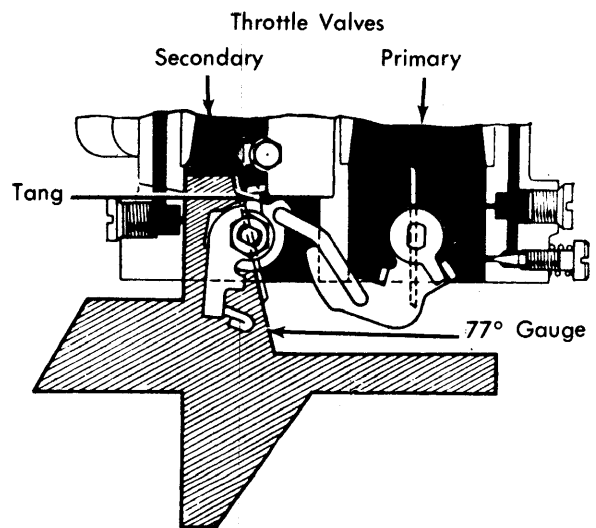

OE1200

**FULL SECONDARY THROTTLE OPENING**

**ACCELERATOR PUMP STROKE**

Measure pump stroke from closed to wide open throttle positions. Plunger stroke should be 7/32" (5.5 mm). Adjust by bending pump connecting link.

# Aisan Carburetors

## AISAN 2-BARREL - TOYOTA 4M ENGINES (Cont.)

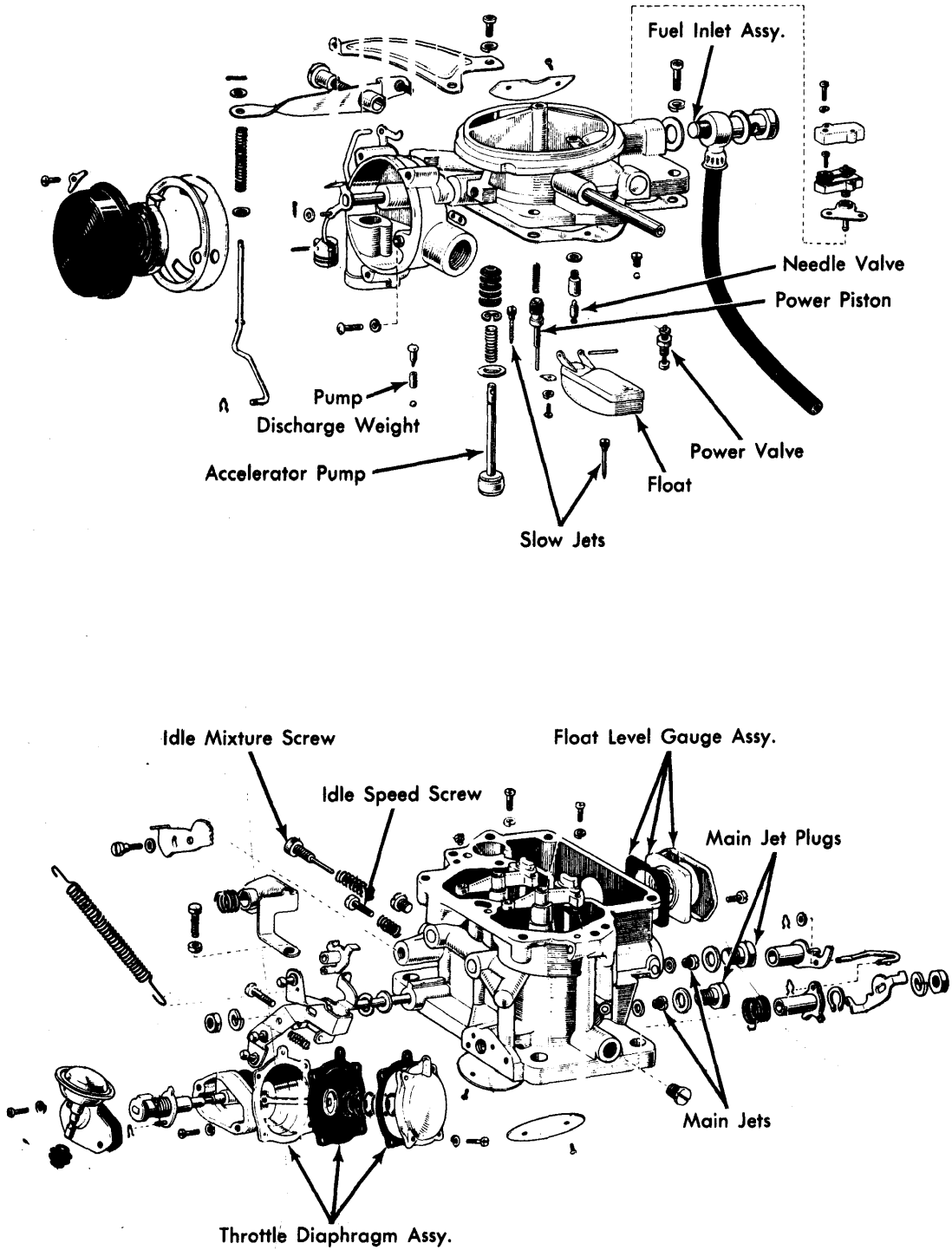

**AISAN 2-BARREL (4M ENGINE)**

# Aisan Carburetors

## AISAN 2-BARREL – TOYOTA 4M ENGINES (Cont.)

### CARBURETOR SPECIFICATIONS

|                               |                        |
|-------------------------------|------------------------|
| Toyota Carb. Part             |                        |
| No. W/A.I.R. ....             | 21100-45040 (MS)       |
| Idle RPM                      |                        |
| Auto. Trans. (In Drive) ..... | 650                    |
| Man. Trans. ....              | 750                    |
| Throttle Positioner RPM       |                        |
| Auto. Trans. ....             | 1200                   |
| Man. Trans. ....              | 1300                   |
| Initial Idle Mixture          |                        |
| Screw Turns Out .....         | 1 2/3                  |
| Accelerator Pump Stroke ..... | 7/32" (5.5 mm)         |
| Automatic Choke .....         | Index                  |
| Unloader .....                | ⊙                      |
| Float Level .....             | .51" (13 mm)           |
| Float Drop .....              | .035-.040" (.9-1.1 mm) |
| Secondary Kick-Up .....       | .008-.016" (.2-.4 mm)  |

⊙ – With W.O.T., choke angle should be 35°.

### OVERHAUL

#### DISASSEMBLY

**Air Horn – 1)** Remove accelerator pump lever with link, cam screw and cam. Remove choke unloader linkage, thermostatic valve with bracket, air horn screws and air horn.

**2)** Remove float pin, float, valve and seat. Remove power piston and spring, choke housing and assembly.

**Carburetor Body – 1)** Remove power valve, plug and choke ball. Remove slow jet, stopper, weight and ball.

**2)** Remove venturis, secondary throttle diaphragm cap, spring and gasket. Unhook positioner spring and remove diaphragm housing cover with dashpot (if equipped). Remove throttle positioner rod, snap ring and diaphragm.

#### CLEANING & INSPECTION

**Cleaning –** Soak all parts (except non-metallic parts) in a suitable carburetor cleaner. Wash parts with water and use compressed air to blow out jets and passage ways.

**Inspection – 1)** Inspect air horn and body for cracks or wear. Check fuel strainer for rust and inspect needle valve and seat assembly for wear.

**2)** Check power piston and valve for wear. Make sure power piston moves freely in bore and inspect pump plunger for wear.

**3)** Check choke coil for deformation, springs for rust or distortion and steel balls for rust and pitting. Inspect diaphragms for leaks or deterioration.

#### REASSEMBLY

To assemble, reverse disassembly procedure.