

AISAN 2-BARREL (TOYOTA KC & 3KC ENGINES)

Toyota Corona (1967-70)

DESCRIPTION

Two barrel downdraft type carburetor, similarly constructed as two single barrel carburetors, but built into one unit. Both primary and secondary systems are provided with double venturi. Each system consists of an air horn, main nozzle, and throttle valve, with one set forming the primary side and the other the secondary side. Primary system is comprised of low speed, high speed, power, acceleration, and choke systems, and is able to supply air-fuel mixture for normal operation. With primary throttle valve fully open, secondary system also operates to supply air-fuel mixture, along with the primary system. The throttle valves of both primary and secondary sides are operated by linkage and are inter-locked, thus making it possible for both throttle valves to be fully open at the same time.

Auxiliary Slow System - On deceleration, manifold vacuum pressure passes thru a sensing line and displaces a diaphragm, opening a valve, and allowing maximum air-fuel mixture into intake manifold.

ADJUSTMENT

Idle Speed & Mixture

With engine at normal operating temperature, remove intake manifold suction hole plug, install an adaptor and connect vacuum gauge and hose. Connect tachometer and run engine at idle speed. Turn throttle valve adjusting screw until engine runs smoothest (without stalling) at the lowest possible RPM. Now turn idle adjusting screw to obtain the highest and most steady vacuum at 670 RPM. Finally set engine to 650 RPM idle speed.

NOTE - Vacuum at idle should be more than 17" Hg. (430 mm).

Fast Idle Speed (Bench)

With choke valve fully closed, measure primary throttle valve opening angle (using gauge #22011, or equivalent). If angle not within specification of 26°, adjust by bending fast idle lever, see illustration.

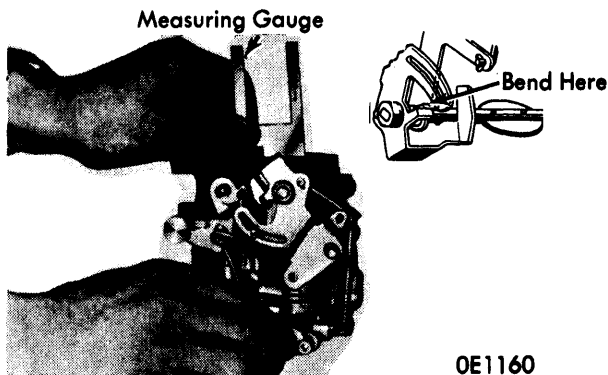

OE1160
FAST IDLE SPEED ADJUSTMENT

Accelerating Pump

Upper hole in accelerator pump connecting link is setting for normal weather operation, lower hole is for extremely cold weather operation.

Primary & Secondary Throttle Valves

With primary throttle valve fully opened, secondary throttle valve should also be fully opened. If necessary, adjust

valve openings by bending throttle shaft link. **NOTE** - Secondary throttle valve should begin to open when primary throttle valve is 60° opened.

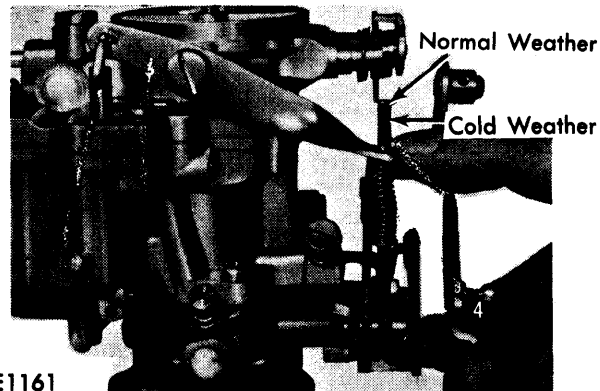

OE1161

PUMP HOLE LOCATION

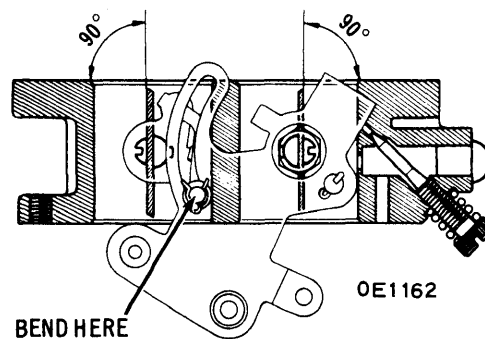

THROTTLE VALVE OPENING

Secondary Throttle Valve Stop Lever

Measure distance between high speed shaft arm and stop lever just as secondary throttle valve begins to open; clearance should be .02" (.5 mm), see illustration.

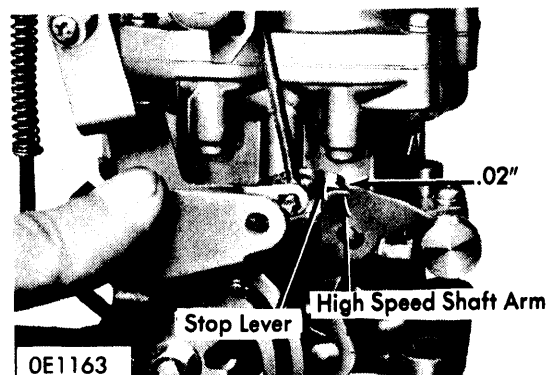

OE1163

MEASURING STOP LEVER

AISAN 2-BARREL (TOYOTA KC & 3KC ENGINES) (Cont.)

Float

Float Level (Raised) – With air horn inverted and using a suitable measuring gauge (09240-22010 or equivalent), check distance between end of float and air horn surface; this clearance should be .26" (6.5 mm). To obtain correct clearance, bend center tab as shown in illustration.

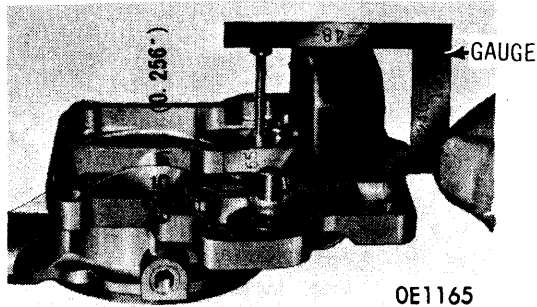

MEASURING FLOAT LEVEL (RAISED)

Float Drop (Lowered) – Measure distance from bottom of air horn surface to lowest point of float using a suitable measuring gauge (09240-22010 or equivalent). Distance should be 1.89" (48 mm) for KC engine, and 1.97" (50 mm) for 3 KC engine. To adjust, bend tabs located on either side of center tab (shown in illustration).

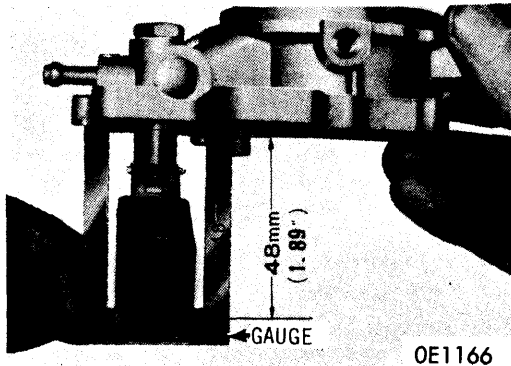

MEASURING FLOAT DROP (LOWERED)

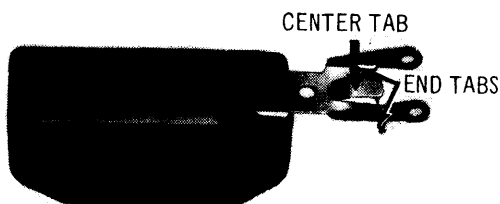

OE1168

FLOAT TAB LOCATION

OVERHAUL

Disassembly

- 1) Disconnect fast idle connector and pump lever connecting link. Remove pump lever retaining screw, pump lever, and disconnect pump connecting link. Remove screws retaining air horn to main body and separate air horn and gasket from main body by lifting air horn straight up.
- 2) Remove pump plunger and dampening spring. Invert carburetor and remove pump discharge weight and check ball, using extreme caution not to lose check ball. Remove flange retaining screws, separate flange from main body.
- 3) Remove float lever pin, float, needle valve with push pin and spring, then remove seat with gasket. Remove power piston stopper retaining screw, and remove power piston and spring. Loosen and remove main passage plug, take out strainer.
- 4) Remove small primary venturi retaining screws, then remove venturi with gasket. Also remove small secondary venturi. From bottom of pump cylinder, remove check ball retainer, invert carburetor and remove check ball. Carefully unscrew and remove slow jet, being careful not to damage threads. Remove primary and secondary main jets along with gaskets.
- 5) Remove drain plug with gasket, then remove power valve, using a suitable tool. Remove power jet from power valve. Remove idle adjusting screw along with spring.

Cleaning & Inspection

- 1) Wash all parts in clean gasoline and blow all fuel passages dry with compressed air. Clean exterior parts with gasoline and a soft wire brush, remove carbon deposits from around throttle valve. Never use wire for cleaning jets.
- 2) Inspect air horn for cracks, nicks, or burrs at gasket surfaces. Check power piston operation by breathing in and out from the hole at center of air horn, check for air leak and smooth piston movement. Inspect float for damage, then inspect "O" ring. Check float needle valve for proper seating by inverting air horn and assembling needle valve and float. Suck in on main fuel passage; if any leakage, valve seating is not satisfactory.
- 3) Inspect strainer for damage or rust. Check choke valve for operation, smooth movement and see that excessive shaft play does not exist; replace as necessary. Inspect main body for cracks, nicks, or burrs at gasket surfaces. Check power valve for smooth operation and proper seating by blowing against valve. Inspect jets for damaged threads or passages. Check for pump plunger wear, then check spring for rust or weakness.
- 4) Check high speed valve for smooth movement; be sure shaft play is minimal. If necessary, replace high speed shaft. Inspect flange for cracks, nicks, or burrs at gasket surfaces. Check idle adjusting screw for damaged threads and good seating surface, also check idle spring for weakness. Check operation of primary and secondary throttle valves, also check for excessive shaft play. Primary throttle shaft play (in direction of shaft) can be adjusted using shims, see "Reassembly".

Reassembly

Reassembly of the carburetor is the reverse of disassembly procedure, except for the following:

AISAN 2-BARREL (TOYOTA KC & 3KC ENGINES) (Cont.)

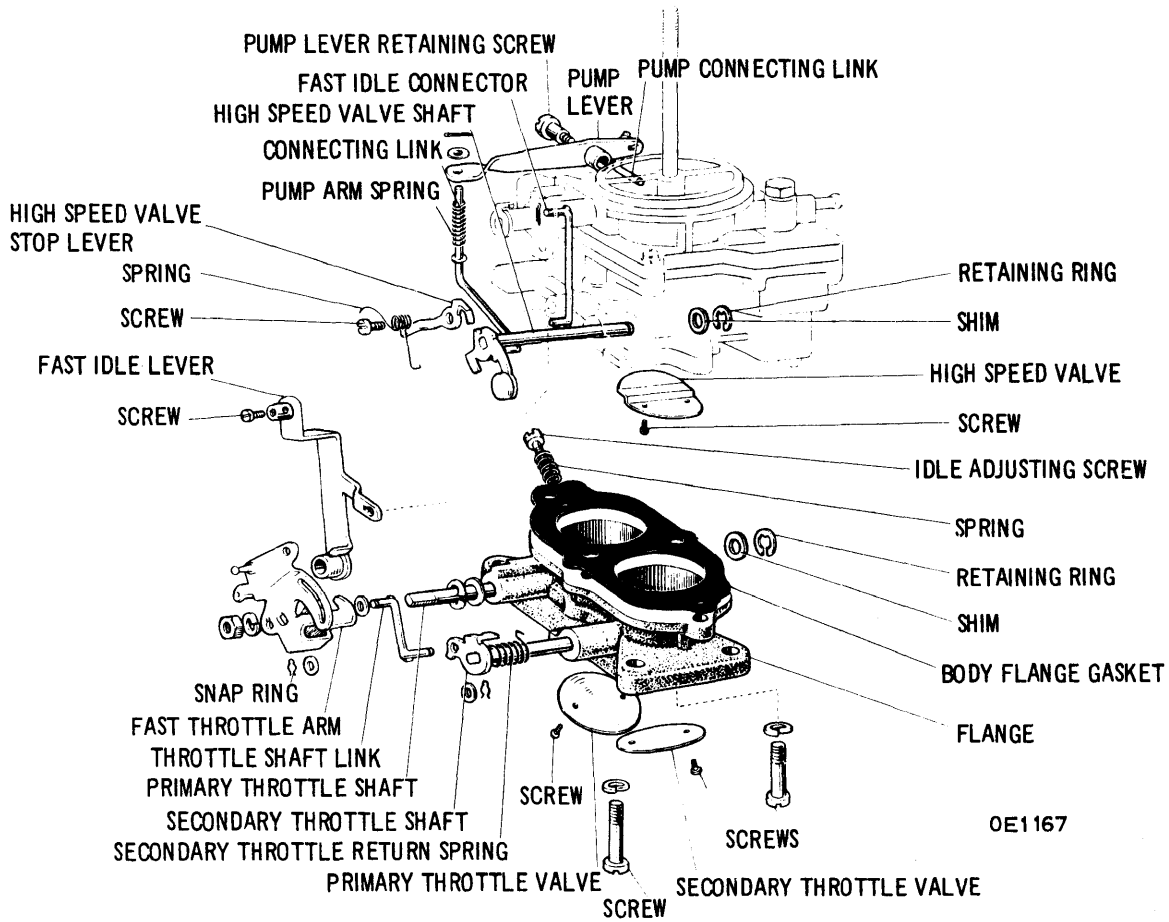

VALVE BODY & LINKAGE

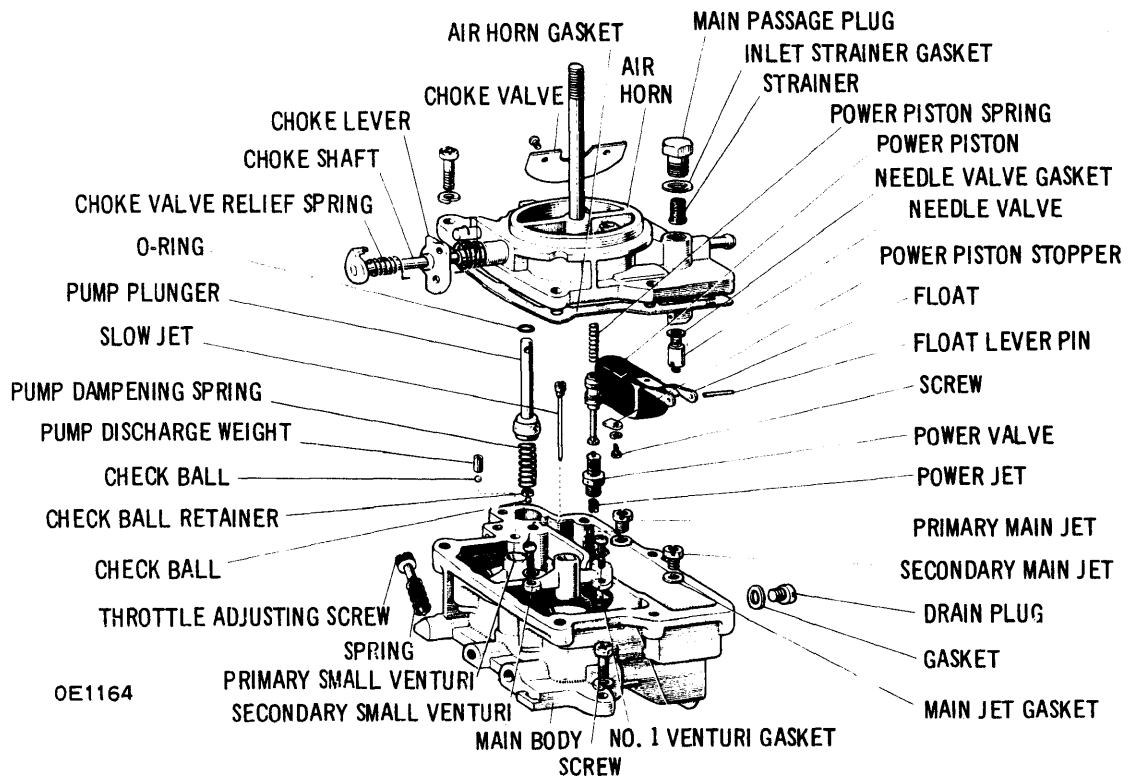

AIR HORN & MAIN BODY (KC & 3 KC)

Aisan Carburetors

AISAN 2- BARREL (TOYOTA KC & 3KC ENGINES) (Cont.)

Choke Valve Replacement - Remove choke valve retaining screws by removing staking, then remove choke valve from shaft; remove shaft along with return spring and relief spring. Reassemble in reverse order using multi-purpose grease.

High Speed Shaft Replacement - Remove staked screws, then remove high speed valve from shaft. Remove retaining ring and pull out high speed shaft. Reassemble in reverse order, noting that it may be necessary to use shims (available in 1 mm and 2 mm, .0039" and .0079" thicknesses) to remove excessive shaft play. Shims may be installed on either or both sides of shaft.

Throttle Valve Replacement - If necessary to replace, disconnect throttle shaft link, remove throttle lever retaining nut, and remove primary throttle shaft arm and fast idle lever. Remove staking, then remove retaining screws and primary throttle valve, remove primary throttle shaft.

Remove retaining ring and pull out primary throttle shaft. Remove secondary throttle shaft and valve in the same manner as primary valve and shaft. To reassemble, follow the disassembly procedures and note that the thin valve plate must be installed to the primary side, while the thick valve plate goes to the secondary side. Also, it may be necessary to install shims on one or both sides of primary throttle shaft, to eliminate excessive shaft play; shims are available in 1 mm, 2 mm, 3 mm (.0039", .0079" & .0118") thicknesses.

Idle Mixture Screw - Lightly seat mixture screw and back out the specified number of turns as a preliminary adjustment.

Engine	Turns Out
KC	2 1/3
3KC	2