

Aisan Carburetors

AISAN 2-BARREL - TOYOTA F ENGINE

Toyota Land Cruiser (1970-73)

DESCRIPTION

Carburetor is of 2-barrel, downdraft design and is equipped with a vacuum operated choke opener to improve operation immediately after starting. A secondary slow port improves fuel mixing at start of secondary valve opening under load at low speed. A throttle positioner prevents throttle from closing completely during periods of deceleration. An anti-diesel switch is also used.

ADJUSTMENT

FLOAT LEVEL ADJUSTMENT

NOTE - A suitable float adjustment kit (09240-60050 or 09240-00010) is available to correctly adjust float level.

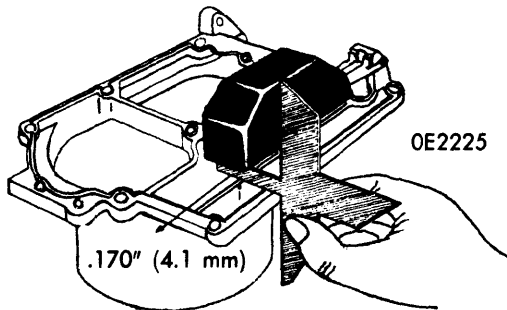

FLOAT LEVEL ADJUSTMENT

Turn carburetor cover and choke housing upside down and measure clearance between top of float and cover surface. If clearance is not as specified, bend middle float tab until correct clearance is obtained.

Float Level Adjustment

Application	Clearance
1970-72310" (8 mm)
1973.....	.161" (4.1 mm)

FLOAT DROP ADJUSTMENT

With carburetor cover top side down raise the float, clearance between needle valve push pin and float tab should be .040" (1 mm) (see illustration). Adjust level by bending the two outside float tabs.

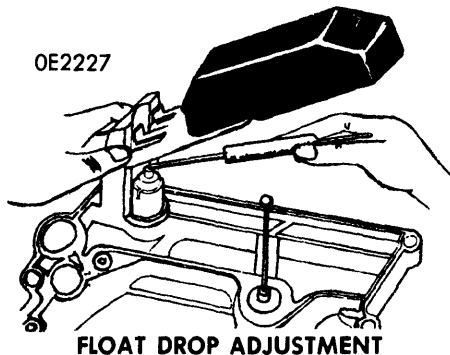

FLOAT DROP ADJUSTMENT

PRIMARY & SECONDARY VALVE ADJUSTMENT

Check opening angles of primary and secondary throttle valves. When primary throttle valve is fully opened the secondary throttle valve should also be fully opened. Adjust, if necessary, by bending throttle shaft link.

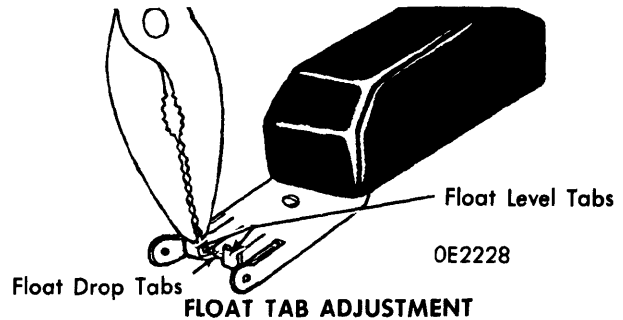

FLOAT TAB ADJUSTMENT

SECONDARY AIR VALVE ADJUSTMENT

A high speed valve is located just above the main throttle butterfly in the secondary throttle bore. A clearance of .040" (1 mm) is required between butterfly and throttle bore (see illustration). To adjust loosen screws and slide valve for proper clearance.

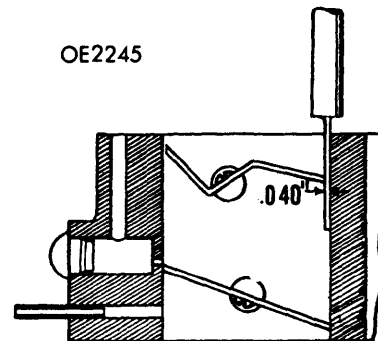

SECONDARY AIR VALVE ADJUSTMENT

ACCELERATOR PUMP ADJUSTMENT

Accelerator pump stroke should be .31" (8 mm). Adjust by bending accelerator pump connecting link. Measurement is taken at boot end of accelerator lever.

THROTTLE POSITIONER ADJUSTMENT

Perform this adjustment with carburetor completely assembled. Pull rubber hose off diaphragm housing to expose it to atmospheric pressure. Turn adjusting screw in until it makes contact with throttle arm and a clearance of .026"-.034" is obtained between lower edge of throttle valve and throttle bore (see illustration). Now adjust gap between throttle arm and screw to .078"-.118" (2-3 mm).

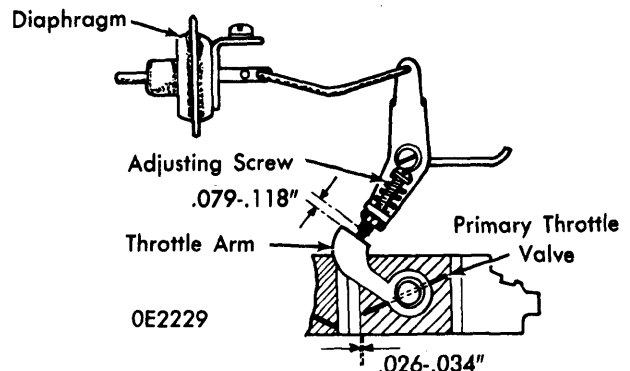

THROTTLE POSITIONER ADJUSTMENT

AISAN 2-BARREL - TOYOTA F ENGINE (Cont.)

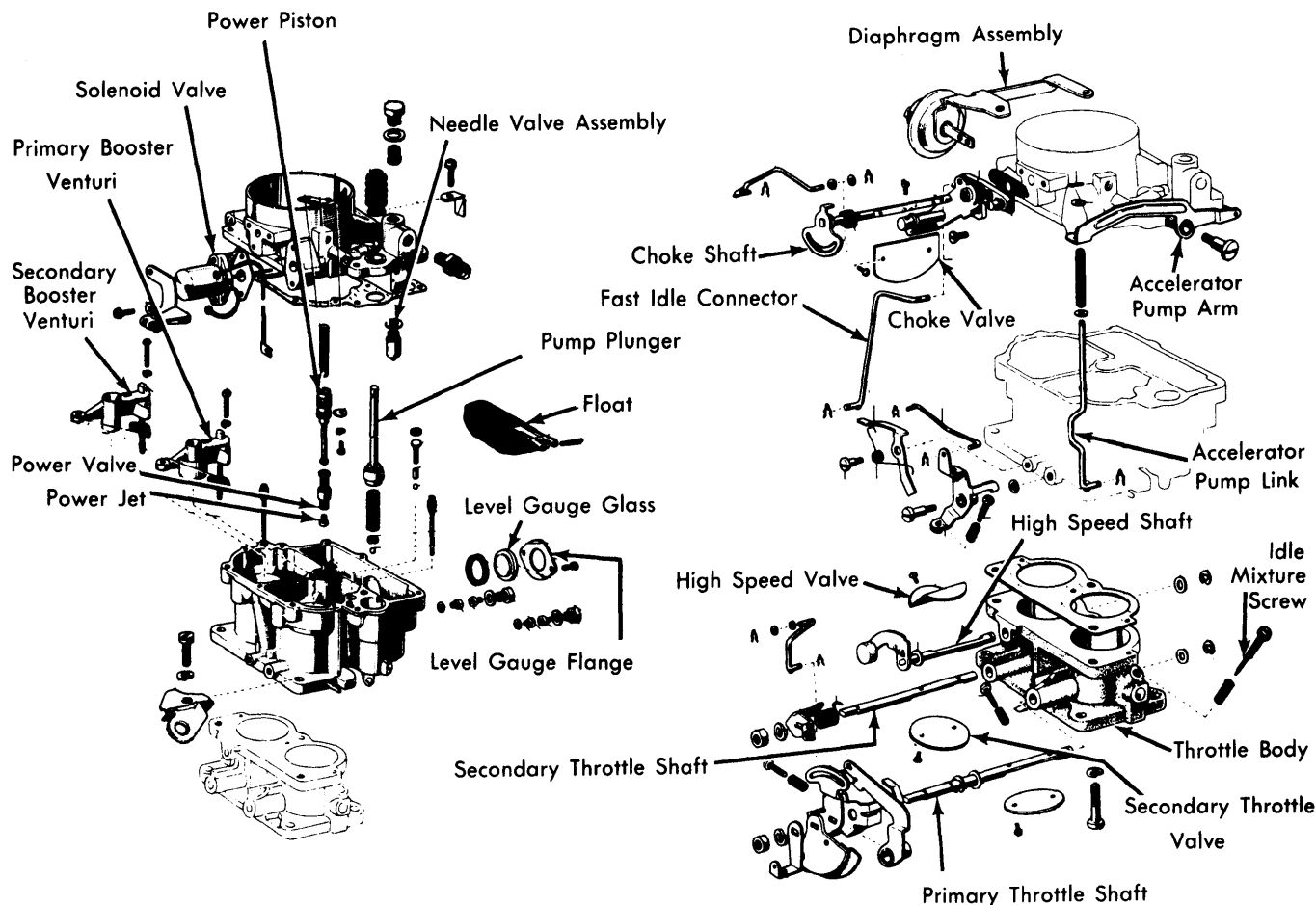

OE2223

CARBURETOR EXPLODED VIEW

CHOKE PULLING ANGLE ADJUSTMENT

Close choke valve fully, and push link rod fully back. Apply .4" vacuum to diaphragm. Adjust, if necessary, by bending link so that valve matches 38° end of gauge. After completing adjustment release link rod and remove vacuum hose. Check to see choke closes fully when lever is pulled.

DAMPER VALVE STOP LEVER ADJUSTMENT

When secondary throttle valve just starts to open adjust the "A" portion so that the clearance between stop lever and arm is .016"-.027" (.4-.7 mm). Adjust by changing angle at point "A" (see illustration).

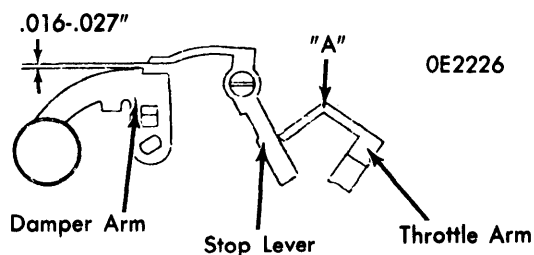

OE2226

DAMPER VALVE STOP LEVER ADJUSTMENT

IDLE SPEED & MIXTURE ADJUSTMENT

With engine at normal operating temperature, air cleaner in place and vacuum gauge and tachometer attached, turn throttle valve adjusting screw in or out until engine operates smoothly without stalling at lowest possible RPM. Turn idle adjusting screw to obtain highest steady vacuum at 600 RPM. Turn throttle valve adjusting screw and idle adjusting screw alternately to obtain highest vacuum reading and smooth operation at 600 RPM. Vacuum should exceed 18" Hg. If CO meter is available, CO reading should be 2-3%.

OVERHAUL

DISASSEMBLY

1) Remove snap ring on bottom of accelerator pump connecting link, remove pump arm screw and pump arm with connecting link. Remove choke wire clamp and magnetic valve. Remove snap ring on choke connecting link, and remove choke connecting link, and likewise remove throttle positioner link and vertical fast idle link.

2) Remove carburetor cover screws and cover. Remove diaphragm and carefully lift off cover taking care not to damage float. Remove accelerator pump plunger spring. Steel ball will remain in place unless retainer is removed.

Aisan Carburetors

AISAN 2-BARREL — TOYOTA F ENGINE (Cont.)

3) Remove pump discharge weight assembly (gasket, stopper, weight, and ball). Remove four Phillips screws securing primary and secondary booster venturis; remove venturis and gaskets. Loosen and remove both slow jets; remove power valve assembly. To remove primary main jet, remove main passage plug. In this passage there will be two jets, one a primary main jet, in use. The other is a spare, not in use, for high altitude (6,600 ft. and up). Remove secondary main jet in same manner.

4) Remove glass level gauge assembly. Remove retaining screws for cast flange and remove flange from carburetor body. Remove throttle positioner lever. Remove high speed valve stop lever and spring.

5) To disassemble flange, remove idle adjusting screw, and remove primary and secondary throttle valves, along with high speed valve. Remove retaining rings on throttle shaft ends and slide throttle shafts from flange. To reinstall, slide the thicker throttle valve onto the secondary

side, the thinner one on primary side. Install from underneath. Throttle shaft end play should not exceed .004" (4 mm). Shims for adjustment come in thicknesses of .004", .008", .012", and .024".

6) To disassemble cover assembly, remove float lever pin and float. Remove needle valve assembly. Remove accelerator pump stopper, accelerator pump, and spring. Remove pump plunger and boot. Remove filter trap and filter. Check choke valve for smooth operation and replace any defective parts.

7) Clean all parts thoroughly, blow out all passages with compressed air.

REASSEMBLY

Be sure to make all adjustments called for in adjustment section and use all new gaskets. Reassembly is in reverse order of disassembly.