

Exhaust Emission Systems

PEUGEOT 404 COPPOLAIR SYSTEM

Peugeot 404 (1968-70)

DESCRIPTION

Peugeot 404 Coppolair exhaust emission control system consists of:

- 1) A Solex 34 PBICA carburetor with econostat. Carburetor is equipped with a device on throttle control which will position throttle in two positions, slow idle (750 RPM) or fast idle (1350 RPM).
- 2) A vacuum diaphragm unit connected to accelerator by an adjustable rod.
- 3) A three-way electro vacuum control valve, which controls diaphragm unit with, either intake manifold vacuum or normal atmospheric pressure.
- 4) Relay and governor which controls electro vacuum control valve. Valve operates up to 21 MPH when increasing speed. When decelerating, valve becomes operational at 17 MPH.

OPERATION

COPPOLAIR EXHAUST EMISSION CONTROL

Starting Vehicle – 1) When starting engine, contact points in governor are closed, completing circuit by grounding solenoid, located in relay.

2) Contact points in relay are closed, allowing current to pass to electro vacuum control valve. Piston activated by electromagnet, closes circuit which draws vacuum from intake manifold. Diaphragm control unit is then controlled by atmospheric pressure.

Vehicle Moving – 1) When vehicle speed reaches 21 MPH, points in governor open breaking circuit to relay. With relay contacts open, vacuum control valve is no longer fed current. Piston is forced back by spring, closing orifice, which was open to atmospheric pressure. Diaphragm control unit is now operated by vacuum from intake manifold, by a connecting pipe, pulls rod (which operates lever on carburetor), until rod adjustment nut rests against vacuum support plate.

2) When accelerator pedal is released, throttle closes, reverting system to operation (No. 1, starting vehicle) described above. Under these conditions, when throttle is slightly open, manifold vacuum is reduced eliminating a too rich mixture.

3) When slowing down and speed reaches 17 MPH, points in governor close again, activating circuit through relay. Vacuum acts upon electro vacuum control valve, causing piston to close circuit. This in turn, allows atmospheric pressure to control vacuum diaphragm unit, returning system to normal idle.

MAINTENANCE

Before adjusting idle or fast idle, ignition timing must be adjusted to 11° BTDC. Engine must be at normal operating temperature, and regulator supply lead disconnected, eliminating engine speed variations due to charging rate of alternator, which can interfere with tachometer readings.

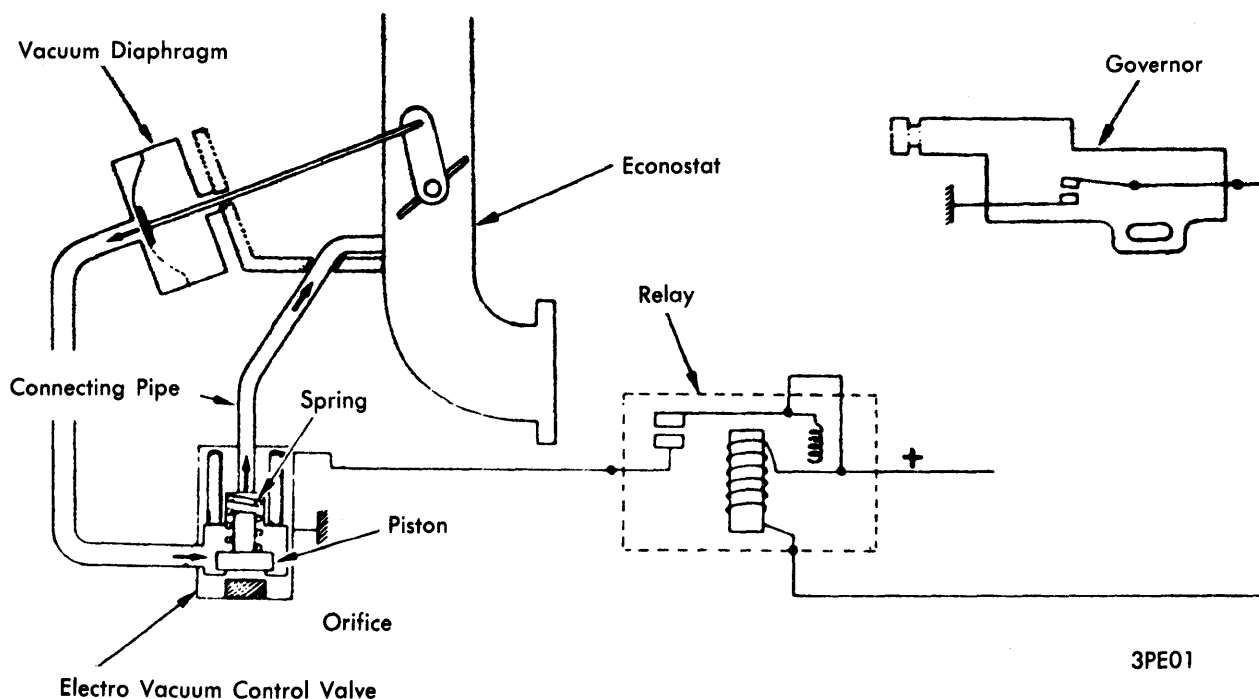

PEUGEOT 404 COPPOLAIR SYSTEM

PEUGEOT 404 COPPOLAIR SYSTEM (Cont.)

Idle Adjustment – Connect tachometer, adjust idle to obtain 790 RPM. Turn, mixture adjusting screw until highest RPM is obtained. Using idle adjusting screw, return idle to 790 RPM. Repeat above operations until idling of 790 RPM corresponds exactly to maximum idling which can be obtained through mixture control variations. Finally, screw in mixture control screw until an idle of 750 RPM is obtained.

Fast Idle Adjustment – Disconnect power lead to either relay or electro-vacuum valve. Loosen lock nut on diaphragm control rod, adjust diaphragm control adjusting nut, located on control rod, until a speed of 1350 RPM is obtained. Tighten lock nut. Reconnect power lead, idling should return to 750 RPM. Reconnect regulator supply lead.

NOTE – All the above adjustments should be carried out at 3,000, 9,000 and 18,000 miles and every 18,000 miles thereafter.

Replacing Electro Vacuum Valve – Remove connecting pipes and power lead. Loosen lower nut, remove valve by sliding it towards front to remove it from support lug. Slide new electro vacuum valve into support lug. Tighten locking nut, reconnect pipes and power lead.

Replacing Governor – Disconnect speedometer drive cable and ground lead. Remove governor holding bolt from reinforcing lug, loosen lock nut and remove securing screw. Remove governor. Install drive pinion of new governor into gear box. Replace governor holding bolt, tighten securing screw slightly

and tighten lock nut. Reconnect speedometer drive cable and ground lead.

Replacing Vacuum Diaphragm Unit – Disconnect vacuum pipe, remove vacuum diaphragm unit securing screws. Unscrew vacuum diaphragm unit from control rod. Tighten new vacuum diaphragm unit on control rod, secure it to its support. Connect vacuum pipe. Adjust both idle and fast idle.

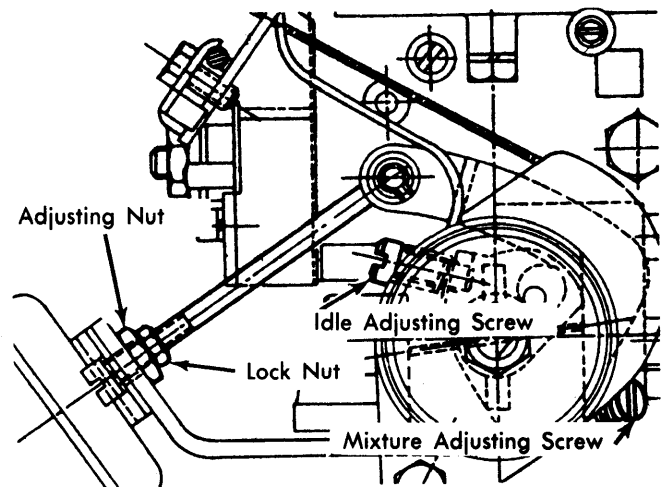

3PE03

IDLING ADJUSTMENTS

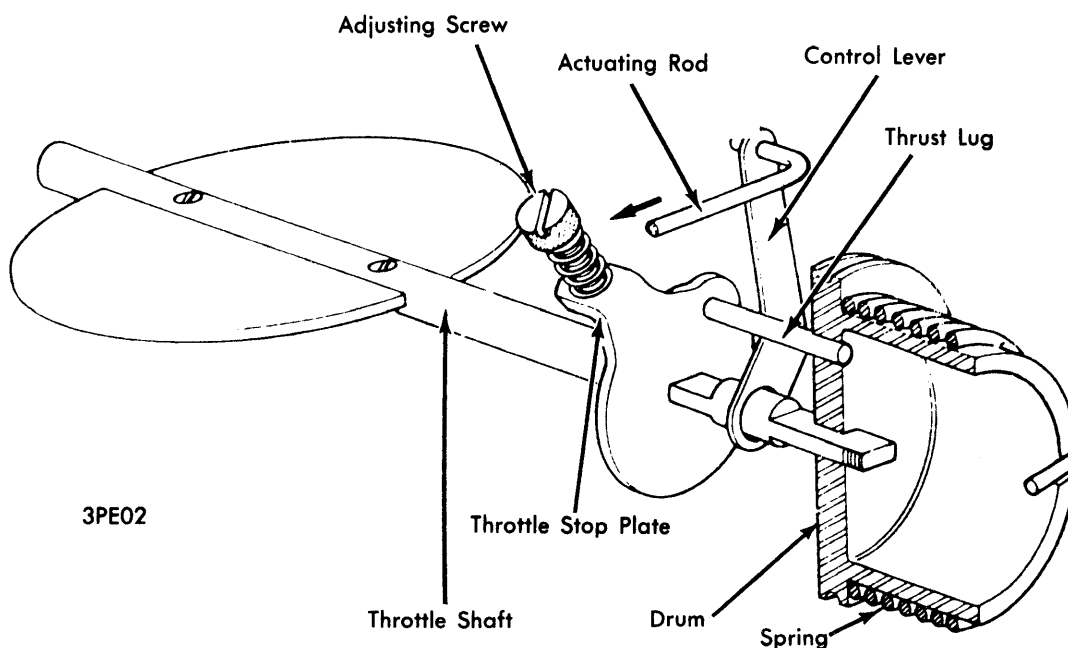

3PE02

FAST IDLE CONTROL