

MAZDA AIR PUMP

1200 (1971)
 616 (1971-72)
 1800 (1971)
 R-100 (1971)
 RX-2 (1971-73)
 RX-3 (1972-73)
 618 (1973)

DESCRIPTION

Vane type pump driven by the vehicle engine compresses air and injects it through the air manifolds, hoses, and injection tubes into the exhaust port area.

OPERATION

Air is drawn into pump from air cleaner. Air pump forces air through a check valve to air injection manifold and then into exhaust ports. Air now unites with exhaust gases in exhaust system and ignites them, thus reducing unburned hydrocarbons to a minimum.

OVERHAUL

If pump is excessively noisy, disassemble and repair as outlined.

DISASSEMBLY

NOTE — Mazda recommends the use of Air Pump Service Tool Kit (49 6500 005).

1) To replace relief valve, remove valve with suitable puller. When installing, position new relief valve on pump housing and hold relief valve replacer on the relief valve. Tap with hammer until valve is seated.

2) Mount pump in suitable holding fixture. **CAUTION** — Do not mount pump housing in vise. With pulley side down, drive out dowels toward pulley. Remove housing cover attaching bolts, and cover by tapping lightly with plastic hammer.

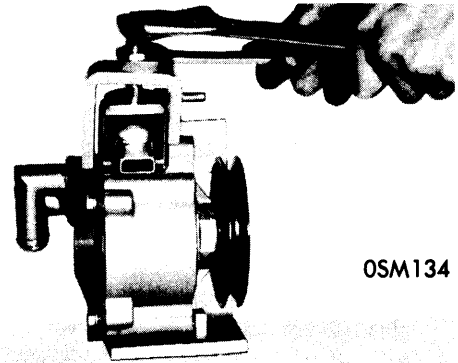

OSM134

RELIEF VALVE REMOVAL

3) Using a suitable tool to hold pulley, remove rotor ring screws. Remove rear rotor ring and bearing assembly, remove rear carbon seal. Remove vane assembly. Remove carbon shoes and springs.

4) To replace bearing in rotor ring, position rotor ring on press with bearing part number facing upward. Using suitable tool press out bearing.

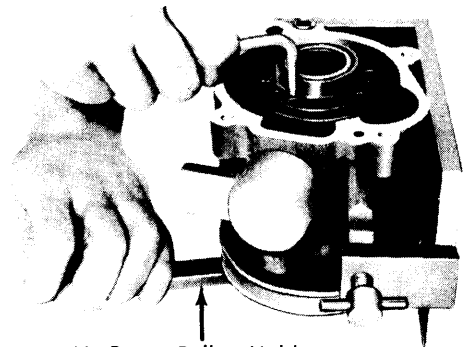

Air Pump Pulley Holder

OSM135

REAR ROTOR RING REMOVAL

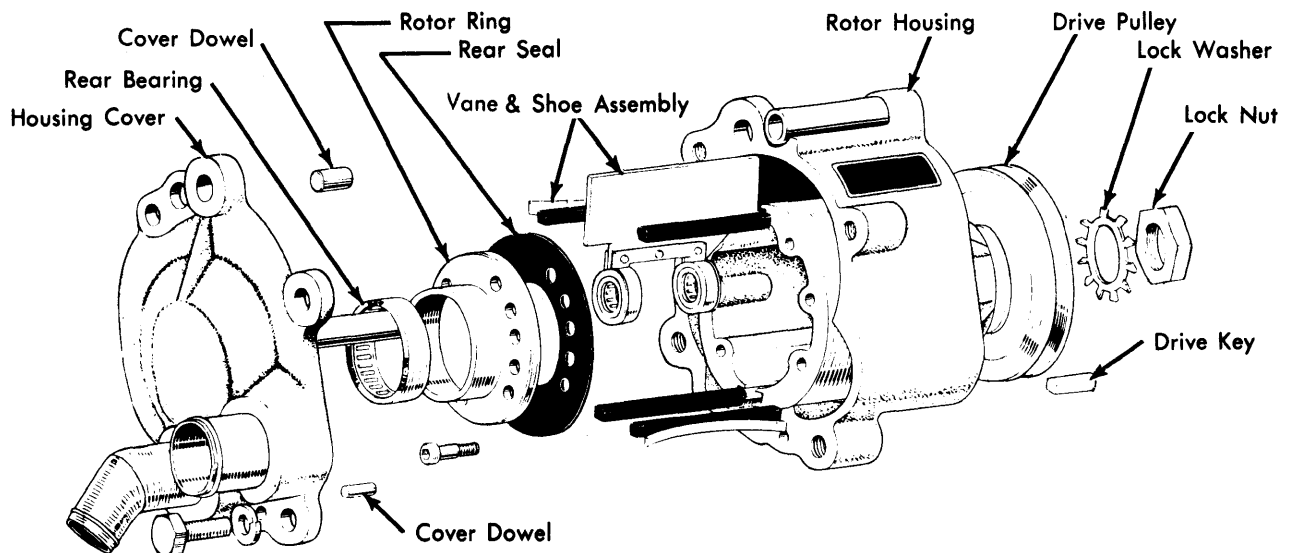

2SM057

AIR INJECTION PUMP (EXPLODED VIEW)

Exhaust Emission Systems

MAZDA AIR PUMP (Cont.)

5) To replace pulley, straighten lock washer tab. Remove lock nut. Using suitable puller remove pulley. **NOTE** — Lock nut is left hand thread.

NOTE — Further disassembly of rotor from pump housing is not recommended. If any component of rotor housing requires replacement, entire housing must be replaced.

CLEANING & INSPECTION

NOTE — Do not immerse housing, rotor and housing cover in solvent as bearings are permanently lubricated.

1) Remove carbon dust and grease from housing, rotor and housing cover. Clean pivot shaft, rear bearing and vane assembly with a suitable solvent.

2) Inspect internal surface of housing for wear or damage by vanes and rotor. If excessively worn, replace. Inspect vane bearing for defect. If defective, replace vane assembly and housing cover assembly.

3) Inspect rear bearing for defect. If defective, replace rear bearing and housing cover assembly. Inspect vane for deformation, wear and damage. Minimum length of vane is 2.35".

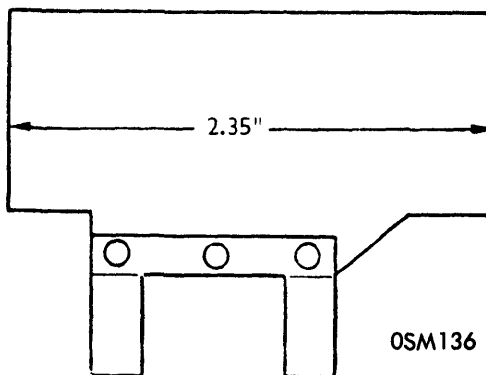

VANE INSPECTION

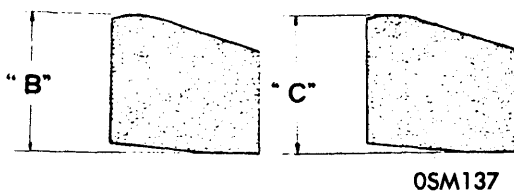

CARBON SHOE INSPECTION

4) Inspect carbon shoes for cracks, wear or damage. Referring to illustration, minimum dimension "B" of shoe installed with spring should be .16" and minimum dimension "C" of shoe installed without spring should be .19".

5) Minimum thickness of rear seal is .016". Inspect shoe spring. Height, at center when placed on flat surface, should be more than .12". Inspect housing cover for cracks or discoloration of pivot shaft. Inspect front bearing for wear.

REASSEMBLY

1) Press rear bearing in with marked side up. Lubricate vane bearings and rear bearing with air pump grease or equivalent. Install pulley, lock washer and lock nut, secure lock nut.

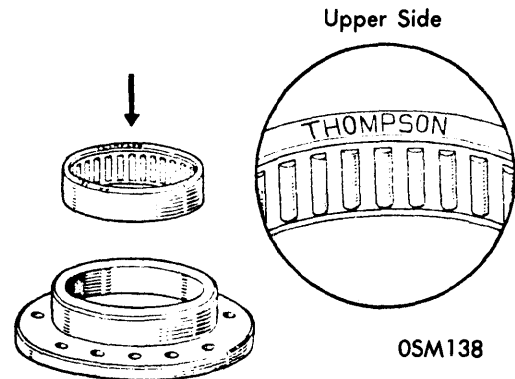

REAR BEARING INSTALLATION

2) Using a suitable tool to hold pulley, insert vanes into housing (blades 180° apart). Position one vane between intake and exhaust chambers as an aid to installing housing cover.

3) Install carbon shoes. Higher one, which is colored white on one end, should be installed in shallowest shoe slot with its colored end toward housing cover side. Install shoe springs into deepest shoe slot with curved surface positioned toward carbon shoe.

4) Position rear seal and rotor ring in place, tighten screws diagonally to 2.7-4.0 ft. lbs. Install housing cover assembly. Loosely tighten attaching bolts. Install dowels toward pulley, then torque attaching bolts diagonally to 7.2-10.3 ft. lbs. **NOTE** — If new vanes were installed, chirping or squeaking may result during initial operation.

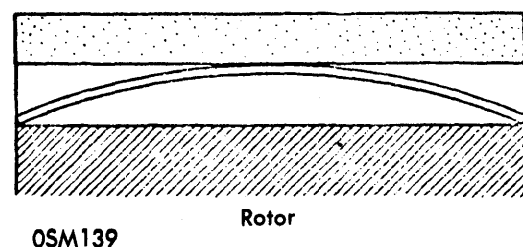
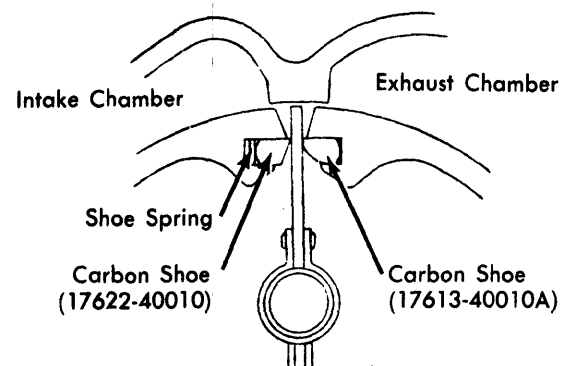

CARBON SHOE INSTALLATION