

JAGUAR V12 ENGINE MODIFICATION

Jaguar V12 (1973)
Jaguar XJ12 (1973)

NOTE — 1973 Jaguar models use Air Injection also.

DESCRIPTION & OPERATION

Solenoid Valve & Pressure Switch — Distributors are equipped with a vacuum retard unit. On cars with manual transmission, vacuum is picked up from throttle edge tapping on left-hand rear carburetor. On cars with automatic transmission, vacuum is sensed in two locations and is equipped with a solenoid valve and pressure switch to select source. The two sources are a throttle edge tapping on left-hand rear carburetor and rear of left-hand front intake manifold. Valve is operated by pressure switch in response to transmission governor pressure. At speeds below 35 MPH, vacuum retard unit is subject to full manifold vacuum and above this speed to a portion of full vacuum.

Thermostatic Vacuum Switch — A thermostatic vacuum switch provides overheating protection. This is necessary due to the high degree of vacuum retard used. This switch cuts off vacuum retard, vacuum supply if engine coolant temperature rises above a specific level. This switch also inhibits operation of throttle by-pass valves as these would normally open due to change in manifold vacuum resulting from advanced spark timing.

Thermostatic Air Cleaners — As carburetors are designed to operate most efficiently at an air intake temperature 105°F, a thermostatic air cleaner is used to maintain this temperature. For additional information, see appropriate story in EMISSION Section.

Exhaust Gas Recirculation — Exhaust gas recirculation (EGR) is used to control NOx emissions. For additional information, see appropriate story in EMISSION Section.

TESTING

Solenoid Valve — With ignition switch OFF, remove vacuum pipes from valve and connect suitable length of hose to thermostatic switch port. Blow into hose, air should emit from throttle edge tapping port. Switch ON ignition, and again blow through hose. Air should be emitted from adjacent port. If valve fails to operate as described, either valve or electrical feed is defective.

Pressure Switch — Remove green lead from connector on transmission kickdown switch. Switch ON ignition and touch lead to connector, solenoid valve should be heard to operate. Reconnect lead to switch and turn OFF ignition. Partially disconnect green-orange lead from solenoid valve and connect test lamp between this lead and ground. Turn ignition ON, test lamp should NOT light and solenoid should be heard to operate. Drive car up to 40 MPH, test lamp should come ON between 35 to 40 MPH. If not, pressure switch is faulty and must be replaced.

Thermostatic Vacuum Switch — Remove switch and connect suitable lengths of tubing to fittings "C" and "D". Blow down tube "D", air should be emitted from tube "C", if not replace switch. Immerse switch bulb in oil bath and heat oil to 220°F. Blow down tube "D", air should be emitted from fittings "F1" and "MT", if not, or if air is emitted from "C", replace switch. Be sure to clean oil from switch before reinstalling.

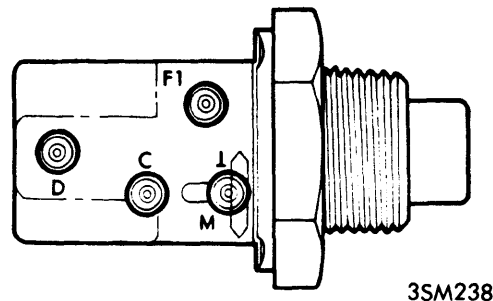

3SM238
THERMOSTATIC VACUUM SWITCH

ADJUSTMENTS

Ignition Timing — Remove distributor cap and rotate engine until "No. 1" timing mark on rotor is in line with central mark on pick-up module housing. Release locknut and set vernier control in center. Slowly rotate engine until timing mark on crankshaft damper is in alignment with correct number on timing plate. Remove number one spark plug from right bank and connect high tension lead to ground. Turn on ignition. Loosen three Allen head screws and rotate distributor as required until a continuous spark is evident at spark plug lead. Tighten Allen screws and finally recheck timing at idle.

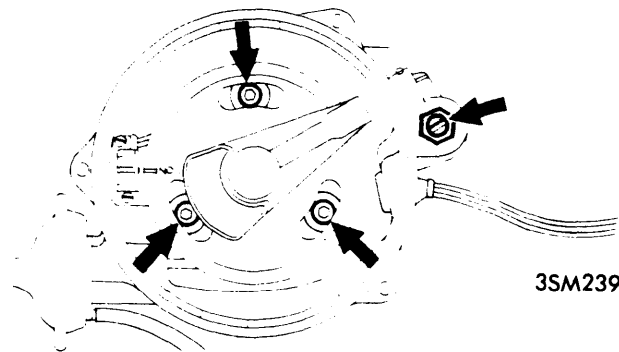

3SM239
IGNITION TIMING ADJUSTMENT

Timing Specifications

All Models	Setting
Static.....	10° BTDC
At Idle.....	4° ATDC

Idle Speed — With engine at normal operating temperature, remove air cleaners and top up carburetor piston dampers with clean engine oil. Disconnect throttle linkage. Ensure that choke control is fully closed. Loosen idle trim screw on each carburetor until it no longer contacts throttle lever. Loosen

JAGUAR V12 ENGINE MODIFICATION (Cont.)

throttle spindle clamping bolts, check that throttles are closed and retighten. Loosen throttle balancing screws. Screw in idle trim screw on right rear and left front carburetors until contact is made with throttle lever. Start engine and adjust idle trim screws on right rear and left front carburetors to obtain an idle speed of 700-750 R/FM, checking that air intake in both carburetors are equal. Screw in right balancing screw until both right side carburetor intakes are equal and repeat on left side. Screw in idle trim screw of right front and left rear carburetors until contact is JUST made with throttle levers. Reconnect throttle linkage and adjust if necessary. Reinstall air cleaners.

Fast Idle Speed - With engine at normal operating temperature and air cleaners removed, operate choke control until mark "A" on front right carburetor is opposite center of fast idle screw. Start engine and adjust fast idle screw to obtain a speed of 1600-1700 RPM. Push choke control closed and measure gap "B" and check that gap is equal on left rear carburetor.

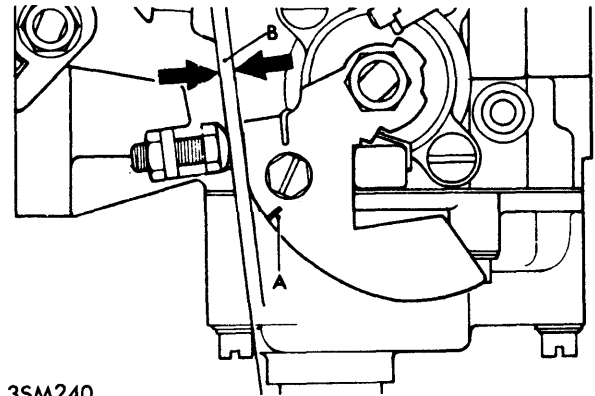

3SM240

FAST IDLE ADJUSTMENT